

# XPLR-HPG-1

## High Precision GNSS evaluation platform

### User guide

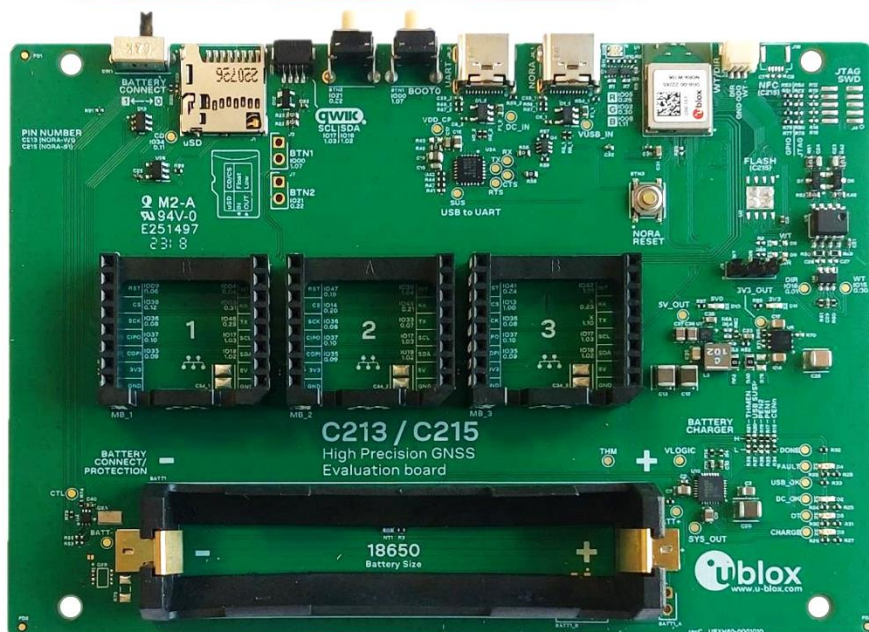

# Document information

<b>Title</b>	XPLR-HPG-1		
<b>Subtitle</b>	High Precision GNSS evaluation platform		
<b>Document type</b>	User guide		
<b>Document number</b>	UBX-23000692		
<b>Revision and date</b>	R03	18-Jul-2024	
<b>Disclosure restriction</b>	C1-Public		

This document applies to the following products:

Product name	Ordering code	Firmware version	Application version	PCN reference
XPLR-HPG-1	XPLR-HPG-1	-	v1.0	N/A

 XPLR-HPG-1 is an application development platform. It has not been RF certified with worldwide agencies. It may not be offered for sale as an end-user product.

u-blox or third parties may hold intellectual property rights in the products, names, logos, and designs included in this document. Copying, reproduction, or modification of this document or any part thereof is only permitted with the express written permission of u-blox. Disclosure to third parties is permitted for clearly public documents only. The information contained herein is provided "as is" and u-blox assumes no liability for its use. No warranty, either express or implied, is given, including but not limited to, with respect to the accuracy, correctness, reliability, and fitness for a particular purpose of the information. This document may be revised by u-blox at any time without notice. For the most recent documents, visit [www.u-blox.com](http://www.u-blox.com).  
Copyright © u-blox AG.

# Contents

<b>Document information</b> .....	<b>2</b>
<b>Contents</b> .....	<b>3</b>
<b>1 Product description</b> .....	<b>5</b>
1.1 Overview.....	5
1.2 Module integration.....	7
1.3 Kit includes.....	8
1.4 Features.....	9
1.5 Correction data use cases.....	9
1.5.1 Case #1: Correction data over L-band satellite.....	10
1.5.2 Case #2: Correction data over Cellular.....	11
1.5.3 Case #3: Correction data over Wi-Fi.....	12
<b>2 Hardware description</b> .....	<b>13</b>
2.1 C213 baseboard.....	13
2.1.1 Block diagram.....	14
2.1.2 Power subsystem.....	14
2.1.3 NORA-W106.....	16
2.1.4 USB.....	17
2.1.5 MikroBUS.....	18
2.1.6 MicroSD.....	19
2.1.7 Qwiic.....	20
2.1.8 Buttons.....	20
2.1.9 Test Points.....	21
2.1.10 LEDs.....	23
2.1.11 RGB LED.....	24
2.1.12 Wheel tick and Direction.....	25
2.2 Click boards.....	27
2.2.1 GNSS RTK 2.....	27
2.2.2 LBAND RTK.....	28
2.2.3 4G LTE 2.....	28
<b>3 Software</b> .....	<b>29</b>
3.1 HPG use case examples.....	29
3.2 u-blox library (ubxlib).....	30
<b>4 Getting started</b> .....	<b>31</b>
4.1 Connecting the antennas.....	31
4.2 Inserting the MicroSD card.....	32
4.3 Inserting the SIM and battery.....	32
4.4 Mounting the Click boards.....	33
4.5 Assembling the enclosure.....	34
4.6 Using the kit with the captive web portal.....	35
<b>Appendix</b> .....	<b>36</b>

<b>A Glossary .....</b>	<b>36</b>
<b>Related documentation .....</b>	<b>37</b>
<b>Revision history .....</b>	<b>37</b>
<b>Contact.....</b>	<b>37</b>

# 1 Product description

The XPLR-HPG-1 kit offers a flexible evaluation platform with which to explore possible application scenarios using the PointPerfect augmentation service.

The platform accesses correction data from satellite broadcasts using an L-band satellite GNSS receiver or through IP connectivity using Wi-Fi or LTE.

The correction data, which compensates for satellite and atmospheric errors, is provided by the u-blox PointPerfect GNSS augmentation service and delivered through the Thingstream IoT service delivery platform. See also [Correction data](#)

Figure 1 shows the platform topology and data communication between each system component.

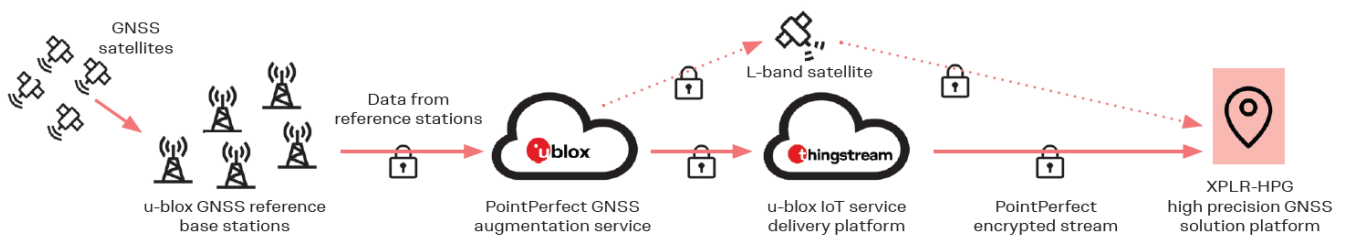

Figure 1: XPLR-HPG-1 platform topology

## 1.1 Overview

Including a single (C213) baseboard that comprises the NORA-W106 standalone radio module and supplied MIKROE Click boards™ hosting the u-blox positioning (ZED-F9R, NEO-D9S) and cellular (LARA-R6) modules. With over 1400 other Click boards to choose from, developers can explore the endless possibilities for combining u-blox modules with the functionality offered by other technology suppliers – using the same kit. Simply plug the modules you want to try into an available mikroBUS connector.

The board assemblies included in the XPLR-HPG-1 kit are shown in [Figure 2](#).

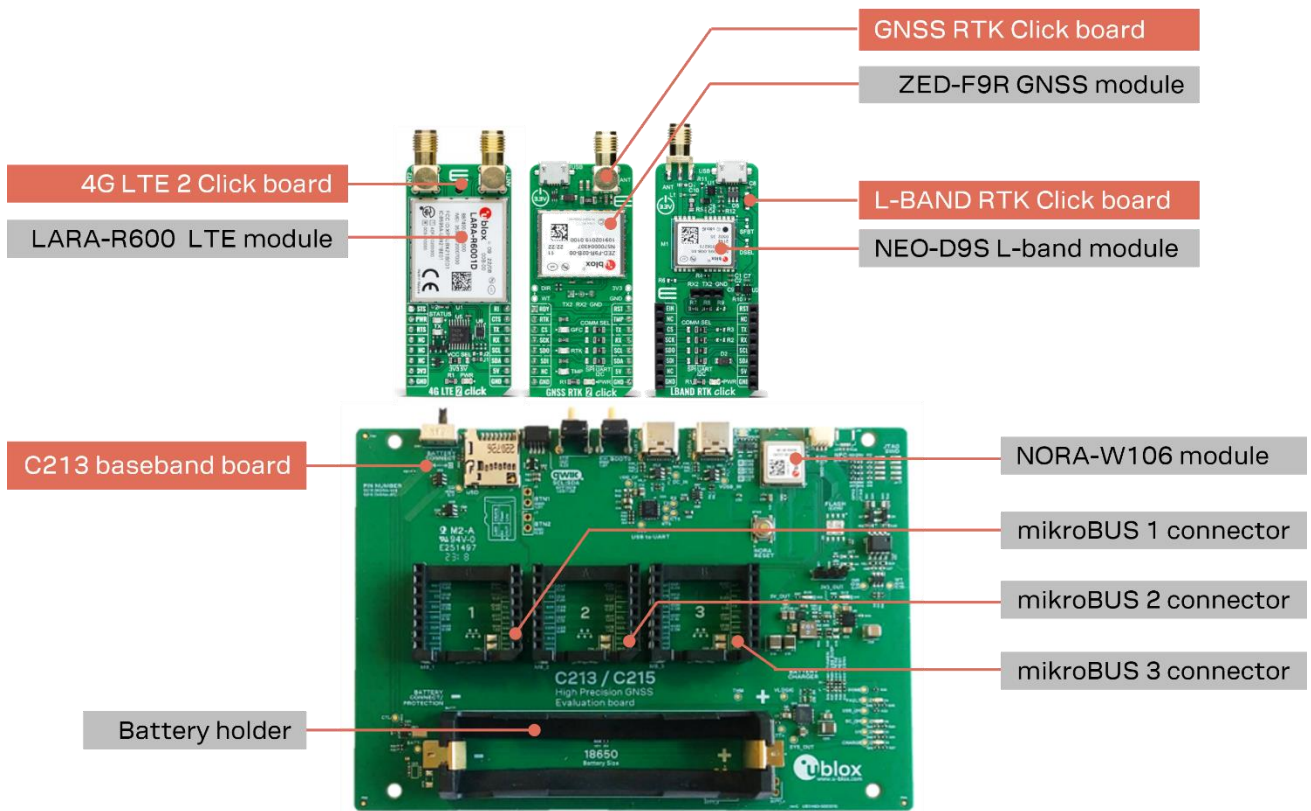



Figure 2: XPLR-HPG-1 board assemblies

## 1.2 Module integration

XPLR-HPG-1 integrates the following positioning, cellular, and short-range radio modules:

- ZED-F9R high precision dead reckoning module [3]: Global navigation satellite system (GNSS) for high-precision GNSS positioning in challenging environments, including:
  - Multi-band GNSS receiver delivers centimeter-level accuracy
  - Native support for PointPerfect GNSS augmentation service
- NEO-D9S correction data L-band receiver module [4]: Processes the correction data necessary for correcting satellite and atmospheric errors. The module processes external corrections to compensate for various imperfections called GNSS errors, with:
  - Access to centimeter-level GNSS corrections globally
  - Freedom to select GNSS correction data delivery channel
  - Allows selection of desired L-band GNSS correction service
- LARA-R6 single or multi-mode LTE Cat 1 cellular module [5]: Modem for Internet of Things (IoT) and Machine to Machine (M2M) applications, including:
  - Secure Cloud
  - Universal connectivity and reliable performance in smallest form factor
  - Reduced logistics complexity, with three regional product variants and extensive certifications from the mobile network operator (MNO)
  - Any region, any band, any technology for simple roaming anywhere in the world
  - World's smallest LTE Cat 1 module - used for cellular applications - with global coverage, ideal for size-constrained devices (LTE CAT-1 = medium speed wireless communication standard specifically designed for Internet of Things (IoT) and Machine to Machine (M2M) use cases).
  - Receive-diversity for reliable performance in difficult conditions
  - Secure by design to always keep your device running and updated
- NORA-W10 stand-alone multiradio module [2], including:
  - Wi-Fi 4 (802.11b/g/n) and Bluetooth Low Energy v5.0 connectivity
  - Internal PCB trace antenna
  - Powerful open CPU for advanced customer applications
  - Small footprint and multiple antenna options

## 1.3 Kit includes

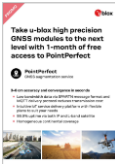
Part	Description	Outline
C213 baseboard	1x C213 baseboard with mounted NORA-W106 stand-alone, multiradio module [2]	
GNSS RTK 2 Click board	1x GNSS RTK 2 Click board [6] featuring the ZED-F9R multi-band GNSS module [3] for high-precision GNSS positioning	
4G LTE 2 Click board	1x 4G LTE 2 Click board [8] featuring the LARA-R6 LTE Cat 1 cellular module [5] for Internet of Things (IoT) and Machine to Machine (M2M) applications	
LBAND RTK Click board	1x LBAND RTK Click board [7] featuring the NEO-D9S satellite receiver for L-band correction [4]	
GNSS antenna	1x GNSS antenna – connects to SMA connector on GNSS RTK 2 Click board	
L-band antenna	1x L-band antenna – connects to SMA connector on LBAND RTK Click board	
LTE antennas	2x LTE antennas – connect to SMA connectors on 4G LTE 2 Click board	
Enclosure	1x enclosure	
USB-C to USB-A cable	1x type USB-C to USB-A cable	
Thingstream promo code	Thingstream promo code with one month of free access to the PointPerfect IP service	
Application software example	Application software example in source code	
AssistNow	AssistNow A-GNSS services	

## 1.4 Features

XPLR-HPG-1 features include:

- 3x mikroBUS™ connectors for plugging up to three Mikroe Click boards™, including the supplied GNSS RTK 2, 4G LTE 2, LBAND RTK boards
- 18650 Li-Ion battery holder accommodating one single-cell Li-ion battery - for easier evaluation in the field (battery not included)
- Battery over-current, over-voltage, under-voltage protection circuits
- On-board battery charging circuit
- USB-to-UART converter exposed on USB-C connector – for easy communication and programming with NORA-W106. Use the same connector to power the system and charge the battery.
- Native NORA-W106 USB exposed on USB-C connector. Use the same connector to power the system and charge the battery.
- Qwiic® connector for evaluating external sensors
- RGB status LED
- 3x buttons for basic functions (Reset, BTN1, and BTN2)
- Wheel tick / direction signal with signal conditioning circuitry
- MicroSD card connector used for logging and persistent memory
- Application software example included in source code
- PointPerfect GNSS augmentation service (1-month free trial account)
- AssistNow A-GNSS services

## 1.5 Correction data use cases

XPLR-HPG-1 can receive correction data over Wi-Fi or Cellular radio links via Thingstream correction service. The NORA-W106 radio module, mounted on the C213 baseboard, provides the Wi-Fi interface, manages the decryption keys, and handles the receipt of GNSS correction data.

To use the u-blox software solution available on GitHub, the supplied Click boards, GNSS RTK 2 (ZED F9R), L-band RTK (NEO-D9S), and LTE 2 (LARA-R6), must be plugged into specific MikroBUS connectors on the C213 baseboard to suit the chosen use case configuration.

The following use cases describe three use cases from the u-blox software:

- [Case #1: Correction data over L-band satellite \(cell and wi-fi\) \(case 1\)](#)
- [Case #2: Correction data over Cellular](#)
- [Case #3: Correction data over Wi-Fi](#)

### 1.5.1 Case #1: Correction data over L-band satellite

In this scenario, the NEO-D9S module, hosted on the L-band RTK Click board, receives correction data from L-band satellites. NEO-D9S frequency range is 1525 MHz to 1559 MHz. The acquired correction data are transmitted to the NORA-W106 module via the I2C interface.

As a pre-requisite for using this configuration, it is necessary to physically stack the ZED-F9R Click board on top of the NEO-D9S. In this way, the modules share correction data with NORA-W106 over I2C. This means that NORA-W106 is not involved in the computation of correction data between NEO D9S to ZED F9R.

The active components in this use case are highlighted red in [Figure 3](#).

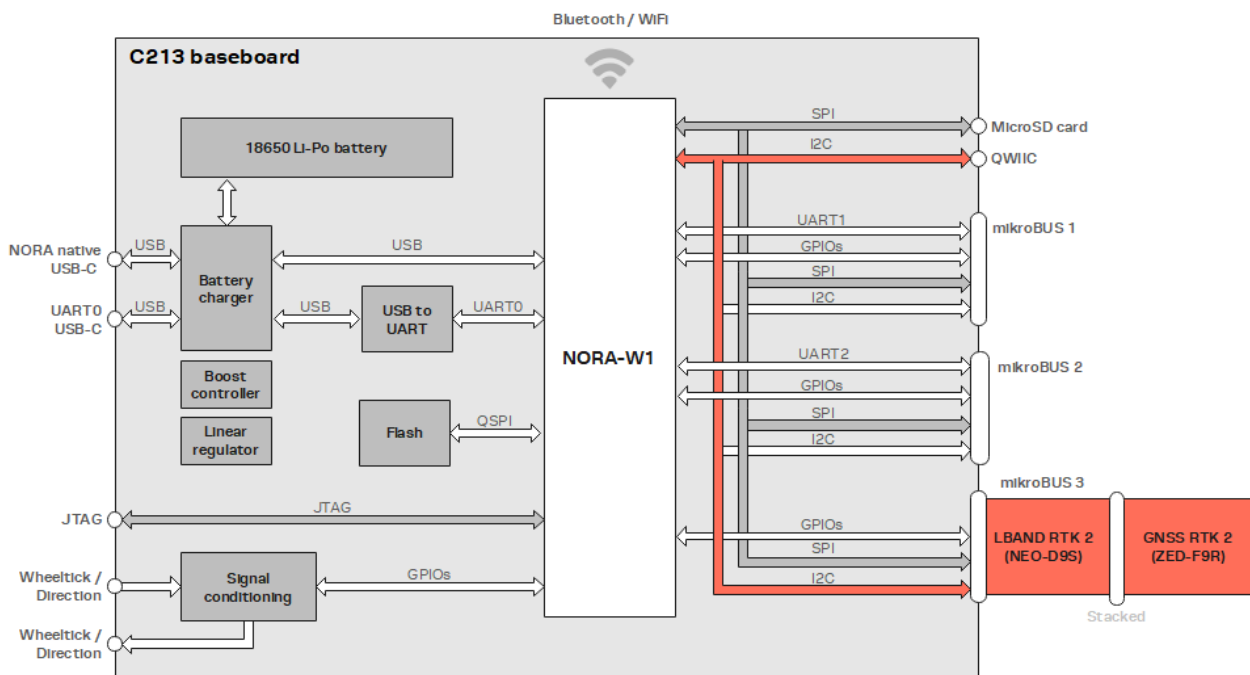

**Figure 3: Correction data flow (L-band)**

NORA-W106 forwards the decryption keys for the correction data packages to ZED-F9R. The decryption keys, which change monthly, can be downloaded from the internet using the Message Queuing Telemetry Transport (MQTT). The keys are downloaded over the Wi-Fi/Bluetooth connection through NORA-W106 or otherwise over a cellular connection through other third-party Click boards.

For the example software, build instructions, and description of this use case configuration, see also [Correction data over L-band \(cellular and Wi-Fi\)](#).

## 1.5.2 Case #2: Correction data over Cellular

In this scenario, the flow starts when the LARA-R6 modem (hosted on the 4G LTE 2 Click board) acquires correction data and the decryption keys through the cellular network using an MQTT connection. After that, NORA-W106 requests the correction data via the UART interface and then forwards to the GNSS RTK 2 Click board (ZED-F9R) through the I2C interface. Moreover, the NORA-W106 module also addresses the decryption keys for the correction data packages to ZED-F9R.

The active components in this use case are highlighted red in [Figure 4](#).

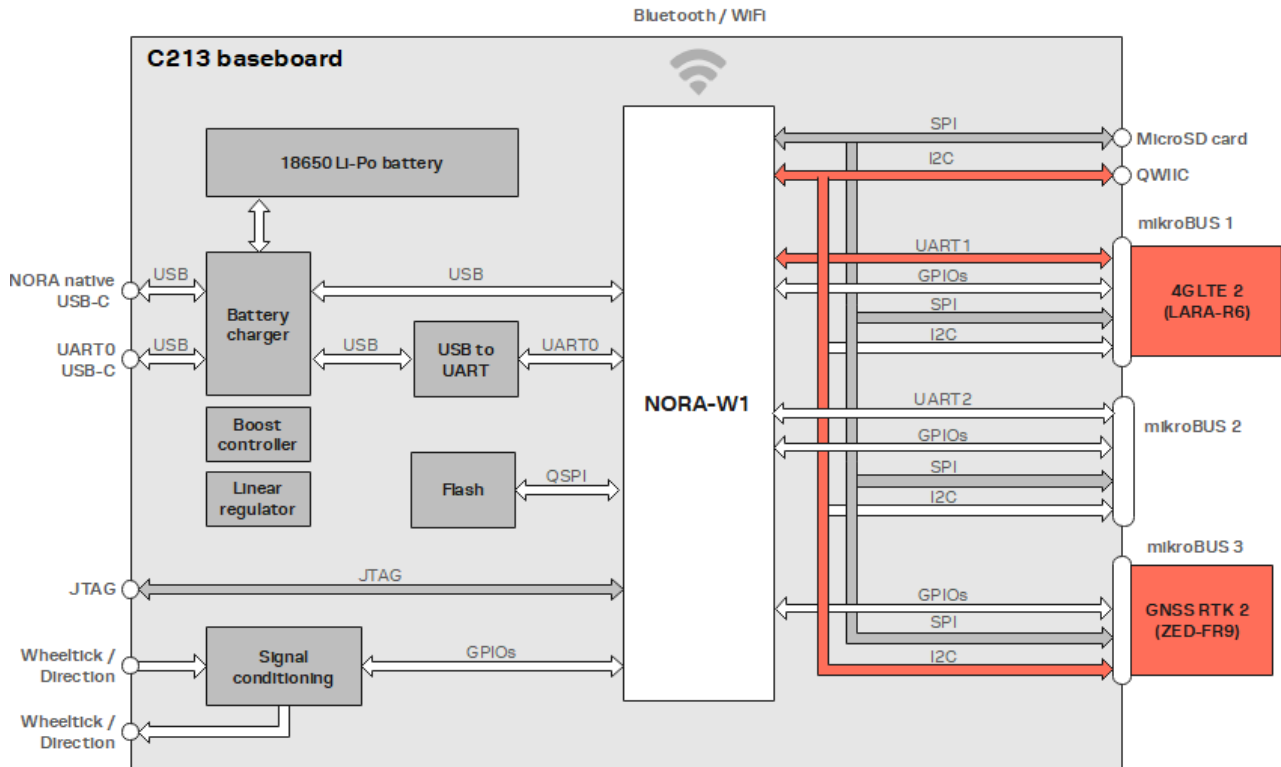

**Figure 4: Correction data flow (LTE Cat1 modem)**

The GNSS RTK 2 Click board (ZED-F9R) can work with the UART or I2C interfaces. On the C213 baseboard, the UART interface is available on the mikrobus 1 and 2 slots. NORA-W106 does not support UART on mikroBUS 3.

For the example software, build instructions, and description of this use case configuration, see also [Correction data over Cellular](#).

### 1.5.3 Case #3: Correction data over Wi-Fi

In this scenario, the Wi-Fi MCU NORA-W106 receives the correction data and the decryption keys through a Wi-Fi network using an MQTT connection. Next, the correction data and the decryption keys are forwarded to the ZED-F9R module (hosted on the GNSS RTK 2 Click board) over the I2C interface.

The active components in this use case are highlighted red in [Figure 5](#).

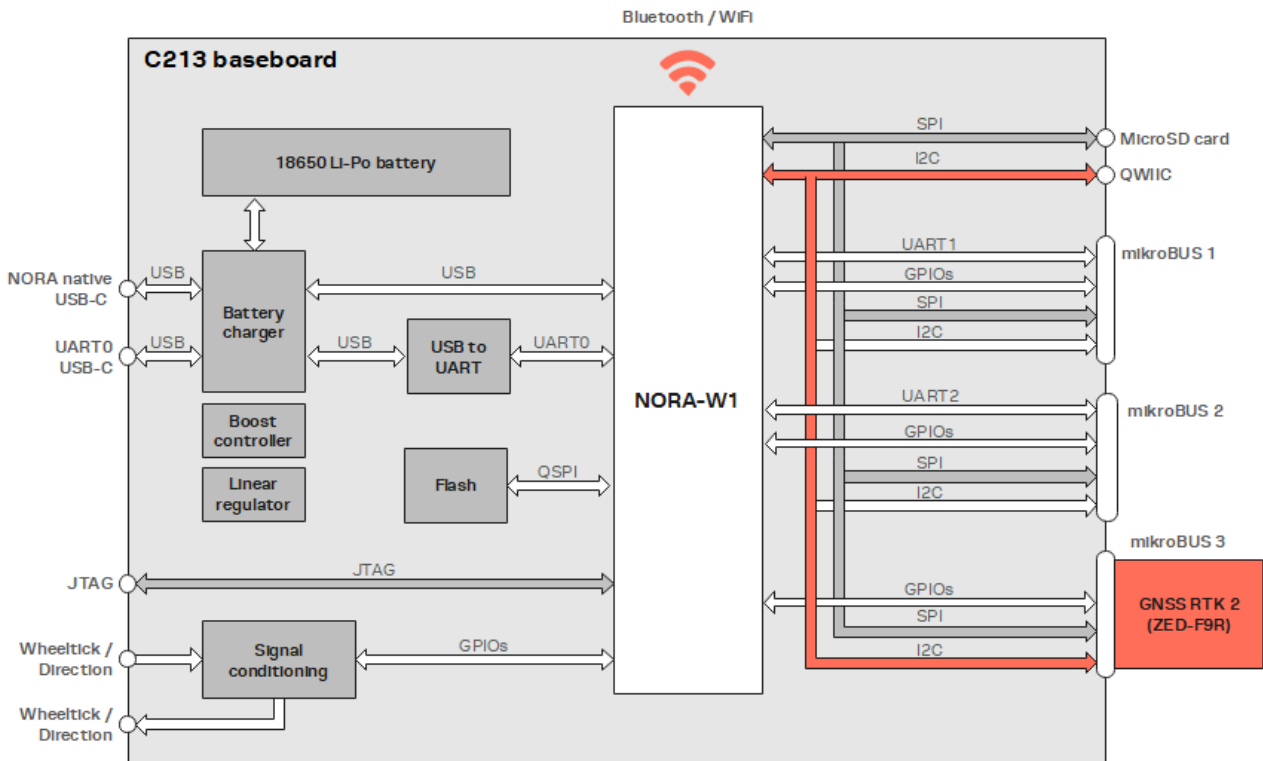

**Figure 5: Correction data flow (Wi-Fi)**

- The GNSS RTK 2 Click board (ZED-F9R) communicates correction data over the UART or I2C interfaces. The C213 baseboard supports a UART interface on mikroBUS slots 1 and 2. NORA-W106 does not support UART on mikroBUS 3.

For the example software, build instructions, and description of this use case configuration, see also [Correction data over Wi-Fi](#).

## 2 Hardware description

### 2.1 C213 baseboard

Figure 6 shows the supported physical interfaces and other key components on the C213 baseboard, including:

- NORA-W106 stand-alone multiradio module (U1)
- 3x mikroBUS™ connectors (MB1, MB2, and MB3) for plugging up to three Mikroe Click boards™, including the GNSS RTK 2, 4G LTE 2, and LBAND RTK Click boards supplied with the kit.
- 18650 Li-Ion battery holder for accommodating one single-cell Li-ion battery (BATT1)
- USB-to-UART converter exposed on USB-C connector for easy communication and programming with NORA-W106, system power and battery charging (J6\_2)
- Native NORA-W106 USB-C connector exposing USB, system power and battery charging (J6\_1)
- Qwiic® connector for evaluating external sensors (J22)
- User-defined LED (RGB)
- 3x buttons for basic functions (NORA Reset, BTN1, and BTN2)
- Wheel tick / direction connector (J2)
- MicroSD card connector (J1)

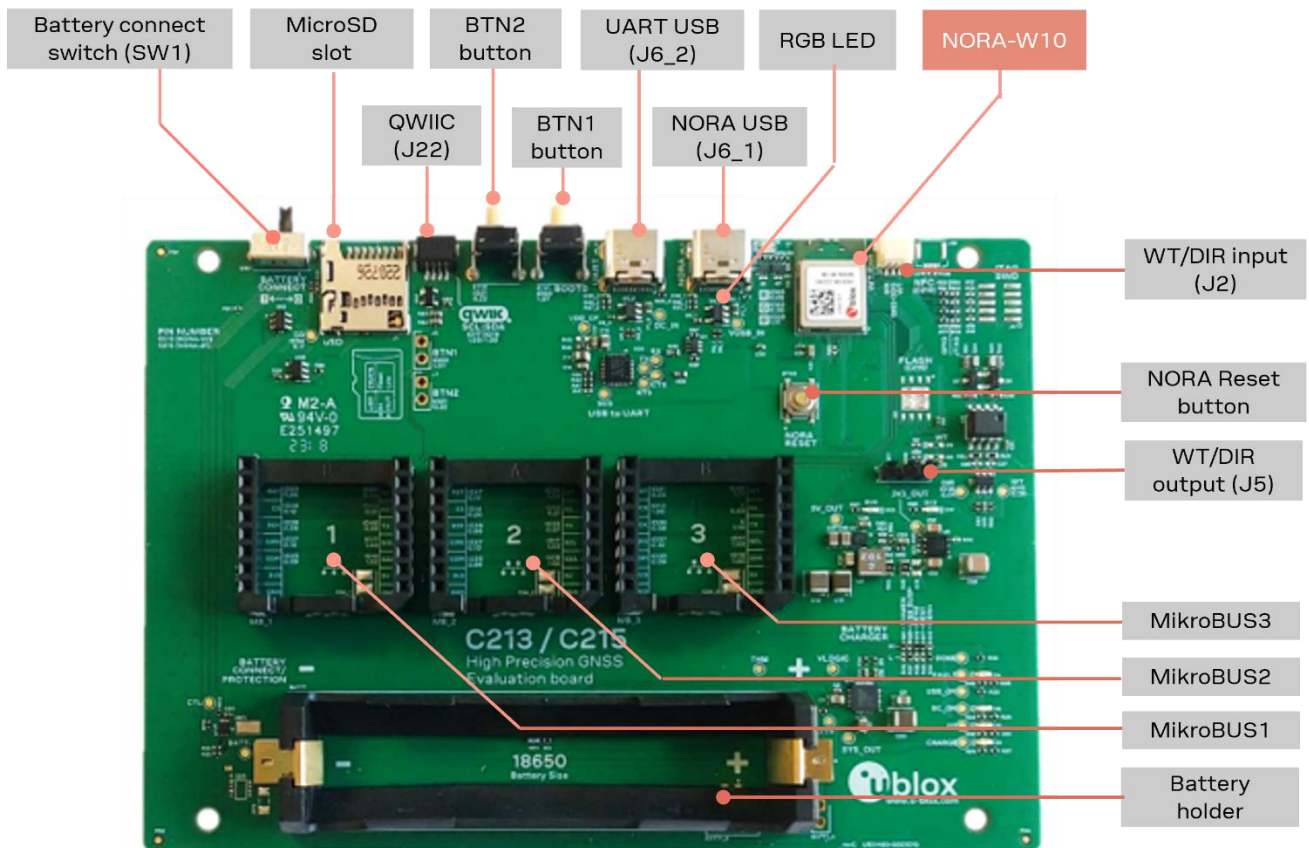

Figure 6: C213 baseboard assembly

## 2.1.1 Block diagram

Figure 2 shows the interfaces between the logical components of the C213 baseboard, including the host NORA-W106 multiradio module, power subsystem, USB, MicroSD, mikroBUS, Qwiic, and signal conditioning interfaces.

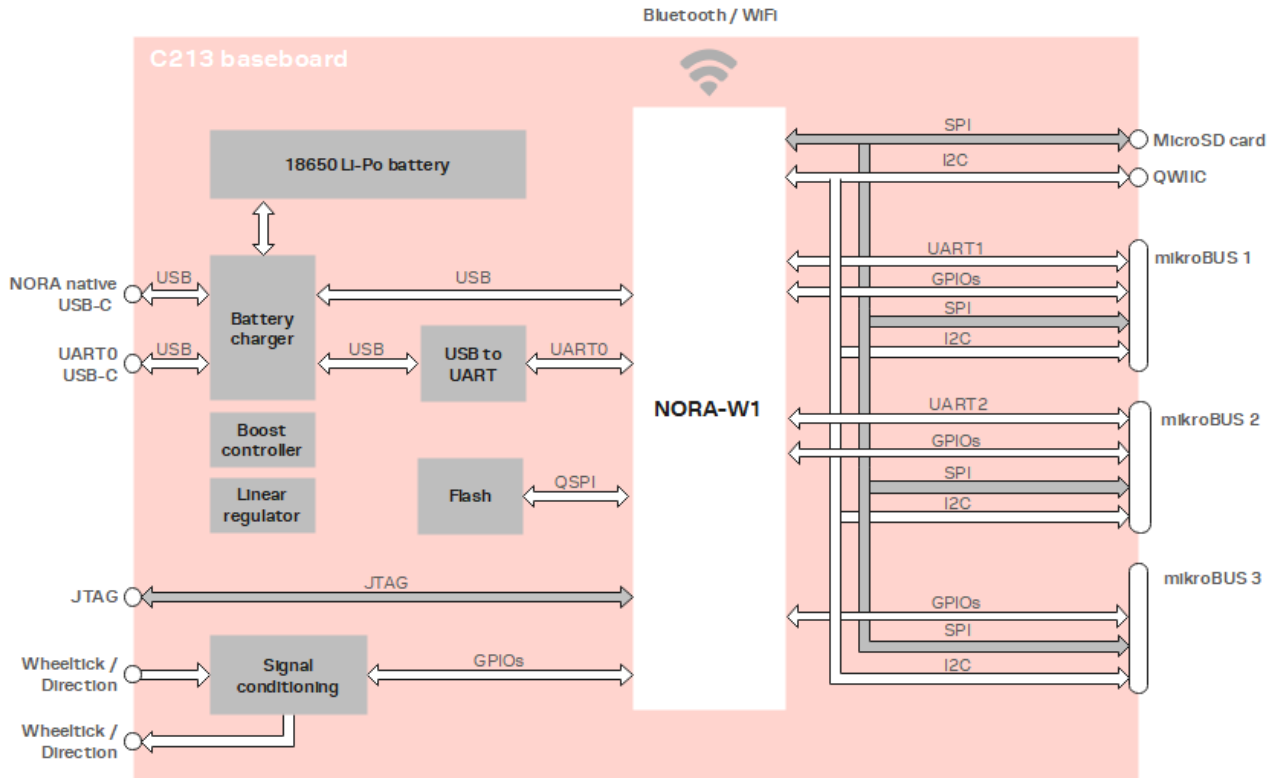

Figure 7: XPLR-HPG-1 block diagram

## 2.1.2 Power subsystem

XPLR-HPG-1 can be powered by either of the USB-C connectors (UART USB or NORA USB) or the on-board battery, as shown in Figure 8.

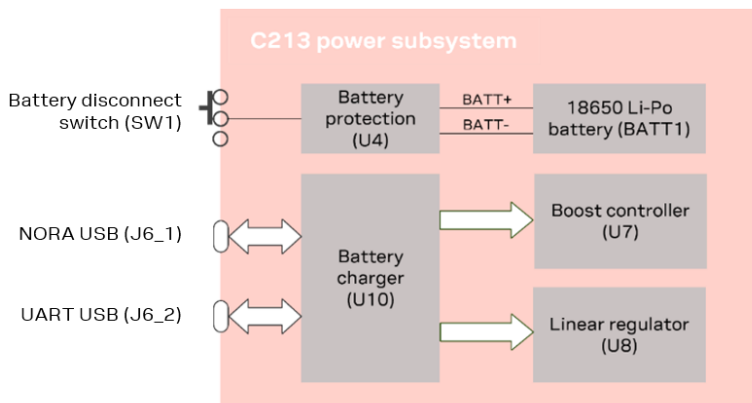

Figure 8: XPLR-HPG-1 power subsystem

Power from the USB-C connectors go through a dual-input linear Li+/Li-Poly battery charger. The charger can use the power sources available (USB-C connectors and battery) to supply the consumption of the board and the additional Click boards. The output of the charger circuit is used by a DC-to-DC boost converter that is responsible for supplying 5 V to the board. There is also a linear power supply that is responsible for supplying the 3.3 V.

### 2.1.2.1 Battery charger

XPLR-HPG-1 is equipped with a MAXIM MAX8934 dual-input linear charger for Li+/Li-Poly 1 cell battery. The charger is supplied by either the USB-C UART (J6\_2) or the USB-C NORA (J6\_1). If both USB-C are connected, the USB UART takes precedence (with regards to power supply). Input current is limited to 2 A and the charging current is limited to 1.35 A. When the input current is reached, first the battery charging current is limited, then the charging stops, and if the power demand is even greater, the battery is connected to support the load.

### 2.1.2.2 Battery

An unprotected, flat top 18650 (one cell) Li-Ion/Li-poly battery can be used for powering up the XPLR-HPG-1. Insert the battery in the BATT1 battery holder. Polarity of the battery should follow the silkscreen of the PCB. See also [Figure 9](#). The battery is charged whenever a USB-C is connected and whenever there is excessive power to the system. The yellow “CHARGE” LED is lit when battery is charging.

- ⚠** XPLR-HPG-1 is designed to work exclusively with 18650 cells that feature an “unprotected, flat top” configuration, for example, the LG HG2 INR18650, Samsung INR18650 or other variants. It is advisable to use Li-Ion batteries (rechargeable). Implementing an incompatible cell can seriously damage both the XPLR-HPG-1 kit itself and the battery unit. The battery is not included in the XPLR-HPG-1 kit.



Figure 9: Battery holder, polarity



Figure 10: Battery LEDs

### 2.1.2.3 Battery protection

The evaluation board includes an on-board circuit that protects against overcurrent, over voltage and under voltage. SW1 (battery connect/disconnect switch) switches the battery connection circuit connects and disconnects the battery from the board circuit. [Figure 11](#) shows SW1 “battery connect” and “battery disconnect” positions.

When in “battery disconnect” position, power for the system is only drawn from one of the two USB-C connectors. In this configuration the battery is not charged.

In the “battery connect” position, power for the system is drawn from the USB-C. If more power is needed than what USB-C can provide, then battery is used to supply the excessive power. If there is excessive power on the USB-C, it is used to charge the battery.

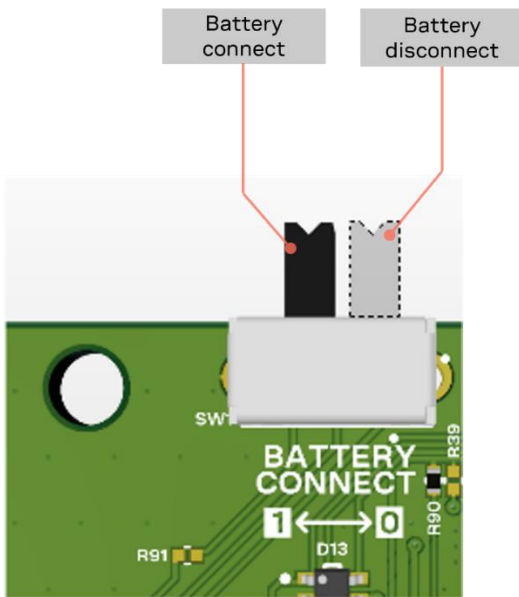

Figure 11: SW1 (battery connect switch) positions

- Every time the battery is physically removed from the holder, the battery protection circuit changes to disconnect state (for battery saving reasons). To change to normal state again, connect an external charger.

### 2.1.3 NORA-W106

NORA-W106 can be programmed with the main application code. [Table 1](#) describes the connections of NORA-W106 to different functions.

NORA-W106 pin	ESP32-S3 GPIO	Function
F7	GPIO0 / Boot	BOOT0/BUTTON-1
C8	GPIO21	BUTTON-2
A3	GPIO17 (A)	I2C-SCL
B4	GPIO18 (A)	I2C-SDA
H9	GPIO8 (A)	LED-B
H8	GPIO2 (A)	LED-G
J8	GPIO5 (A)	LED-R
E8	GPIO1 (A)	MB1-AN
D8	GPIO4 (A)	MB1-INT
E9	GPIO7 (A)	MB1-PWM
E7	GPIO9 (A)	MB1-RST

NORA-W106 pin	ESP32-S3 GPIO	Function
J9	GPIO3 (A)	MB1-RX
H7	GPIO46	MB1-TX
G3	FSPIIO5 / GPIO11 (A)	MB2-AN
J2	JTAG_TCK / GPIO39	MB2-INT
H3	FSPIIO4 / GPIO10 (A)	MB2-PWM
F3	SPICLK_P / GPIO47	MB2-RST
E3	SPICLK_N / GPIO48	MB2-RX
D3	FSPIHD / GPIO33	MB2-TX
G2	FSPIIO6 / GPIO12 (A)	MB3-AN
H2	JTAG_TMS / GPIO42	MB3-INT
G1	MTDO / GPIO40	MB3-PWM
H1	JTAG_TDI / GPIO41	MB3-RST
J3	RESET_N	RESET_N
C1	FSPIQ / GPIO37	SPI-CIPO
B1	FSPICLK / GPIO36	SPI-CLK
C2	FSPID / GPIO35	SPI-COPI
B3	FSPICS0 / GPIO34	SPI-CS0
A2	FSPIWP / GPIO38	SPI-CS1
A5	FSPIDQS / GPIO14 (A)	SPI-CS2
A6	FSPIIO7 / GPIO13 (A)	SPI-CS3
F9	GPIO6 (A)	UART0-CTS
F8	GPIO45	UART0-RTS
G9	U0RXD / GPIO44	UART0-RXD
G8	U0TXD / GPIO43	UART0-TXD
D9	USB_N / GPIO19	USB-D-
C9	USB_P / GPIO20	USB-D+
B6	XTAL_32K_N / GPIO16 (A)	WT/DIR-DIR
C6	XTAL_32K_P / GPIO15 (A)	WT/DIR-WT

**Table 1: NORA-W106 pad connections**

## 2.1.4 USB

### 2.1.4.1 NORA USB (J6\_1)

USB-C connector (J6\_1) is connected directly to pins C9, D9 of NORA-W106. Power supply is connected to the secondary input of the battery charger IC. This port is the native NORA-W106 can be used to communicate directly through USB.

### 2.1.4.2 UART USB (J6\_2)

UART USB-C connector (J6\_2) is connected to a Silicon Labs CP2102N-A02-GQFN24 USB-to-UART bridge. It is connected to pins G8, G9, F8 and F9 (UART0 of NORA-W106) as shown in [Table 2](#).

NORA-W1 pin	ESP32-S3 GPIO	Function
F8	GPIO45	UART0-RTS
F9	GPIO6 (A)	UART0-CTS
G8	U0TXD / GPIO43	UART0-TXD
G9	U0RXD / GPIO44	UART0-RXD

**Table 2: NORA-W1 USB to UART bridge connections**

XPLR-HPG-1 supports an auto reset circuit connected to the **BOOT0** and **RESET** pins of NORA-W106, as shown in [Figure 12](#). This circuit enables programming tools like the `esptool.py` to assert the DTR and RTS control lines of the USB to Serial converter (CP2102N) and set NORA-W106 on the serial bootloader mode. See also Espressif ESP32 Automatic Bootloader documentation [\[9\]](#).

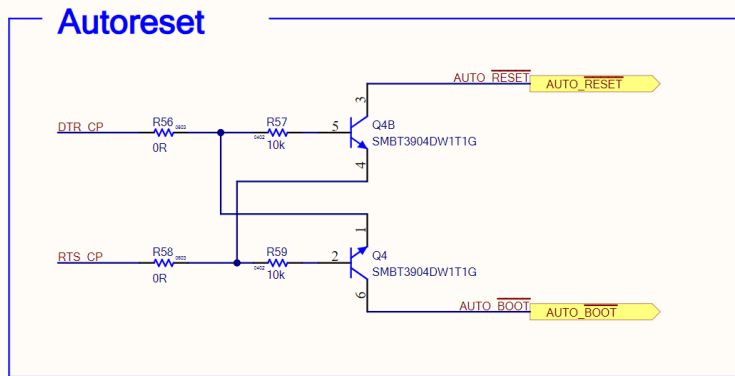

**Figure 12: NORA-W106 auto reset circuit**

## 2.1.5 MikroBUS

XPLR-HPG-1 board has three MikroBUS connectors with available space to nestle three large size Click boards. Each MikroBUS connector exposes:

- 3x GPIOs (RESET, PWM, INT)
- 1x analog input (AN)
- 1x UART (2 wire)
- 1x I2C bus
- 1x SPI bus with one CS (chip select) line for each mikroBUS slot

For further information about the mikroBUS standard, visit the mikroBUS website [\[10\]](#).

**⚠** Connecting a third-party Click board with IOs referenced at 5 V can seriously damage because the board. The NORA-W106 I/Os and the Click boards provided in the XPLR-HPG-1 kit are referenced at 3.3 V.

[Table 3](#) shows the mikroBUS pin connections.

mikroBUS pin	mikroBUS 1		mikroBUS 2		mikroBUS 3	
	NORA-W106	ESP32-S3 GPIO	NORA-W106	ESP32-S3 GPIO	NORA-W106	ESP32-S3 GPIO
1 - AN	E8	GPIO1 (A)	G3	FSPIIO5 / GPIO11 (A)	G2	GSPIIO6 / GPIO12 (A)
2 - RST	E7	GPIO9 (A)	F3	SPICLK_P / GPIO47	H1	JTAG_TDI / GPIO41
3 - SPI-CS	A2	FSPIWP / GPIO38	A5	FSPIDQS / GPIO14 (A)	A6	FSPIIO7 / GPIO13 (A)
4 - SPI-SCK	B1	FSPICLK / GPIO36	B1	FSPICLK / GPIO36	B1	FSPICLK / GPIO36
5 - SPI-CIPO	C1	FSPIQ / GPIO37	C1	FSPIQ / GPIO37	C1	FSPIQ / GPIO37
6 - SPI-COPI	C2	FSPID / GPIO35	C2	FSPID / GPIO35	C2	FSPID / GPIO35
7 - 3.3 V	3.3V	3.3V	3.3V	3.3V	3.3V	3.3V
8 - GND	GND	GND	GND	GND	GND	GND
9 - GND	GND	GND	GND	GND	GND	GND
10 - 5V	5V	5V	5V	5V	5V	5V
11 - I2C-SDA	B4	GPIO18 (A)	B4	GPIO18 (A)	B4	GPIO18 (A)
12 - I2C-SCL	A3	GPIO17 (A)	A3	GPIO17 (A)	A3	GPIO17 (A)



The NORA-W106 module can check if the CS0 signal is low. If it is low, then there is no card at the MicroSD card slot and can set an interrupt to the pin to be notified for a card insertion event. If the CS0 signal is high, then the card is inserted, and can proceed to initialize the SPI peripheral.

Table 4 describes the pins used on the MicroSD card slot.

NORA-W106 pad	ESP32-S3 GPIO	Function
C1	FSPIQ / GPIO37	SPI-CIPO
B1	FSPICLK / GPIO36	SPI-CLK
C2	FSPID / GPIO35	SPI-COPI
B3	FSPICSO / GPIO34	SPI-CS0 / CARD DETECT

Table 4: NORA-W106 to MicroSD connections

## 2.1.7 Qwiic

XPLR-HPG-1 board has a standard Qwiic connector (J22) for connecting external I2C devices of the Qwiic ecosystem. The interface includes two 2.2 kΩ pull-up resistors referenced to 3.3 V on the SDA and SCL signals. The signals are shown on each mikroBUS slot.

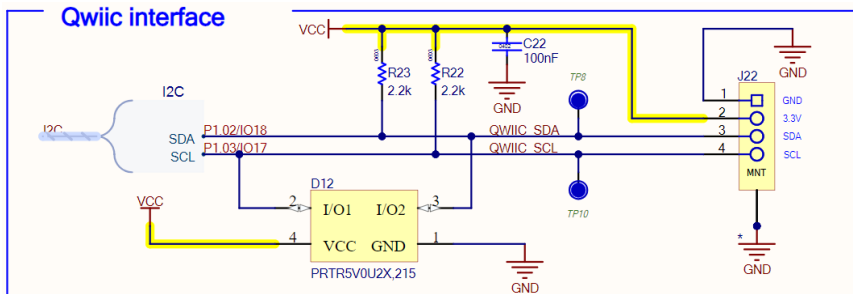

Figure 14: Qwiic connector

## 2.1.8 Buttons

XPLR-HPG-1 supports three buttons (RESET, BTN1, and BTN2). The schematic circuit of these buttons is shown in Figure 15. The buttons are accessible from the front side of the PCB.

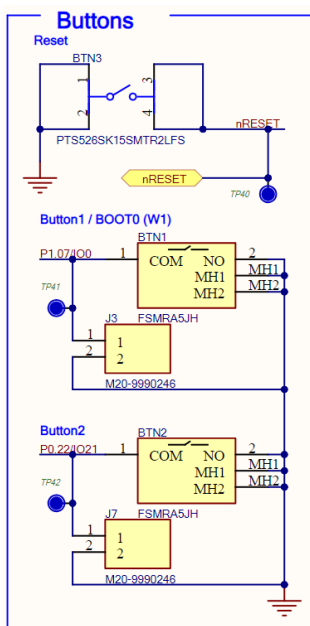

Figure 15: XPLR-HPG-1 buttons

Table 5 describes the connections to NORA-W106 and the functionality of each button.

NORA-W106 pin	Button	ESP32-S3 function	Function
F7	BTN1 / BOOT0	GPIO0 / Boot	Connected to BOOT0/GPIO0 pin of the integrated MCU (ESP32-S3) in NORA-W1. Press and hold this button during bootup to put NORA-W1 into bootloader mode. After bootup, use this button as a general-purpose software button for discretionary use in the application.
C8	BTN2	GPIO21	Connected to GPIO21 on NORA-W1, use this button as a general-purpose software button for discretionary use in the application.
J3	RESET(BTN3)	RESET_N	Resets the NORA-W106 short-range radio module. Note that this button is not accessible when the C213 baseboard is fitted inside the enclosure.

Table 5: Button pins and functions

## 2.1.9 Test Points

Connector	Signal	Description	Test point
USB1	VBUS	+5 V DC input	TP1_1
USB1	D+	Differential signal	TP2_1
USB1	D-	Differential signal	TP3_1
USB2	VBUS	+5 V DC input	TP1_2
USB2	D+	Differential signal	TP2_2
USB2	D-	Differential signal	TP3_2
Qwiic	SDA	I2C SDA signal	TP8
Qwiic	SCL	I2C SCL signal	TP10
Qwiic	VCC	+3.3 V DC output	TP5/TP44
Qwiic	GND	Ground	TP7
WT/DIR IN	WT_IN	Wheel Tick input signal	TP34
WT/DIR IN	DIR_IN	Direction input signal	TP37
WT/DIR IN	GND_ODO	Ground	TP12
WT/DIR OUT	WT	Wheel Tick output signal	TP38
WT/DIR OUT	DIR	Direction output signal	TP39
WT/DIR OUT	GND	Ground	TP7
NFC	NFC1	NFC1 signal	TP35
NFC	NFC2	NFC2 signal	TP36
mikroBUS1	AN	Analog input signal	TP4_1
mikroBUS1	RST	Reset output	TP6_1
mikroBUS1	SPI_CS	SPI Chip Select	TP9_1
mikroBUS1	SCK	SPI Clock	TP27
mikroBUS1	MISO	SPI MISO	TP29
mikroBUS1	MOSI	SPI MOSI	TP28
mikroBUS1	VCC	+3.3 V DC	TP5/TP44
mikroBUS1	GND	Ground	TP7
mikroBUS1	GND	Ground	TP7
mikroBUS1	5V	+5 V DC	TP33
mikroBUS1	SDA	I2C SDA signal	TP30
mikroBUS1	SCL	I2C SCL signal	TP31
mikroBUS1	RX	UART RX	TP19_1
mikroBUS1	TX	UART TX	TP18_1

Connector	Signal	Description	Test point
mikroBUS1	INT	Interrupt input	TP17_1
mikroBUS1	PWM	PWM output	TP16_1
mikroBUS2	AN	Analog input	TP4_2
mikroBUS2	RST	Reset output	TP6_2
mikroBUS2	SPI_CS	SPI Chip Select	TP9_2
mikroBUS2	SCK	SPI Clock	TP27
mikroBUS2	MISO	SPI MISO	TP29
mikroBUS2	MOSI	SPI MOSI	TP28
mikroBUS2	VCC	+3.3 V DC output	TP5/TP44
mikroBUS2	GND	Ground	TP7
mikroBUS2	5V	+5 V DC output	TP33
mikroBUS2	SDA	I2C SDA signal	TP30
mikroBUS2	SCL	I2C SCL signal	TP31
mikroBUS2	RX	UART RX	TP19_2
mikroBUS2	TX	UART TX	TP18_2
mikroBUS2	INT	Interrupt input	TP17_2
mikroBUS2	PWM	PWM output	TP16_2
mikroBUS3	AN	Analog input	TP4_3
mikroBUS3	RST	Reset output	TP6_3
mikroBUS3	SPI_CS	SPI Chip Select	TP9_3
mikroBUS3	SCK	SPI Clock	TP27
mikroBUS3	MISO	SPI MISO	TP29
mikroBUS3	MOSI	SPI MOSI	TP28
mikroBUS3	VCC	+3.3 V DC output	TP5/TP44
mikroBUS3	GND	Ground	TP7
mikroBUS3	5V	+5 V DC output	TP33
mikroBUS3	SDA	I2C SDA signal	TP30
mikroBUS3	SCL	I2C SCL signal	TP31
mikroBUS3	RX	UART RX	TP19_3
mikroBUS3	TX	UART TX	TP18_3
mikroBUS3	INT	Interrupt input	TP17_3
mikroBUS3	PWM	PWM output	TP16_3
uSD	uSD_CS	uSD Chip Select	TP32
uSD	uSD_MOSI	uSD MOSI	TP28
uSD	uSD_MISO	uSD MISO	TP29
uSD	uSD_SCK	uSD Clock	TP27
uSD	VCC	+3.3 V DC output	TP5/TP44
uSD	GND	Ground	TP7
JTAG/SWD	SWDIO/TMS	SWDIO/TMS	TP20
JTAG/SWD	SWDCLK/TCK	SWDCLK/TCK	TP21
JTAG/SWD	TDO	TDO	TP13
JTAG/SWD	TDI	TDI	TP54
JTAG/SWD	nRESET	nRESET	TP40
JTAG/SWD	VCC	+3.3 V DC output	TP5/TP44
JTAG/SWD	GND	Ground	TP7

Connector	Signal	Description	Test point
BATTERY	BATT+	Battery positive terminal	TP22
BATTERY	GND	Ground	TP7
BATTERY	BATT-	Battery negative terminal	TP23
BATTERY	CTL	Battery protection IC input control signal	TP55
UART0	TX_CP	USB to UART bridge output (UART0 TX)	TP46
UART0	RX_CP	USB to UART bridge input (UART0 RX)	TP45
UART0	CTS_CP	USB to UART bridge input (UART0 CTS)	TP47
UART0	RTS_CP	USB to UART bridge output (UART0 RTS)	TP48
BTN1	BTN1	See <a href="#">Table 5</a>	TP41
BTN2	BTN2	See <a href="#">Table 5</a>	TP42
BTN3	nRESET	See <a href="#">Table 5</a>	TP40
VDD_CP	VDD_CP	USB to UART bridge input voltage: +3.3VDC	TP49
DC_IN	DC_IN	+5 V DC input	TP51
VUSB_IN	VUSB_IN	+5 V DC input	TP53
VLOGIC	VLOGIC	+3.3 V DC output	TP50
SYS_OUT	SYS_OUT	+4.4 V DC output	TP52
5V_IN	5V_IN	+5 V DC input	TP23
5V	5V_OUT	+5 V DC output	TP33
3V3_IN	3V3_IN	+3.3 V DC input	TP43
VCC	3V3_OUT	+3.3 V DC output	TP5/TP44
GND	GND	Ground	TP7

**Table 6: Test-points list**

## 2.1.10 LEDs

LED	Name	Color	Description
D2	DC_OK	Green	DC Power OK indicator. Turns ON when a valid input power is detected.
D3	CHARGE	Yellow	Battery is charging indicator. Turns ON when the battery is charging.
D4	FAULT	Red	Fault indicator. Turns ON when the battery timer expires before prequal or fast charge complete
D5	OT	Red	Over Temperature indicator. Turns on when battery temperature is $\geq +75^{\circ}\text{C}$ .
D8	WT	Green	Flashes or is permanent green depending on duty cycle of the signal. LED is not mounted
D9	DIR	Green	Flashes or is permanent green depending on duty cycle of the signal. LED is not mounted
D10	5V0	Green	5Volt power good indicator
D11	3V3	Green	3.3Volt power good indicator
RGB	RGB	Red, Green, Blue	User-defined LED. See also <a href="#">Table 8</a> .

**Table 7: LEDs indication description**

### 2.1.11 RGB LED

XPLR-HPG-1 supports a single RGB LED that is located on the front side edge of the PCB. The circuit connections are shown in [Figure 16](#).

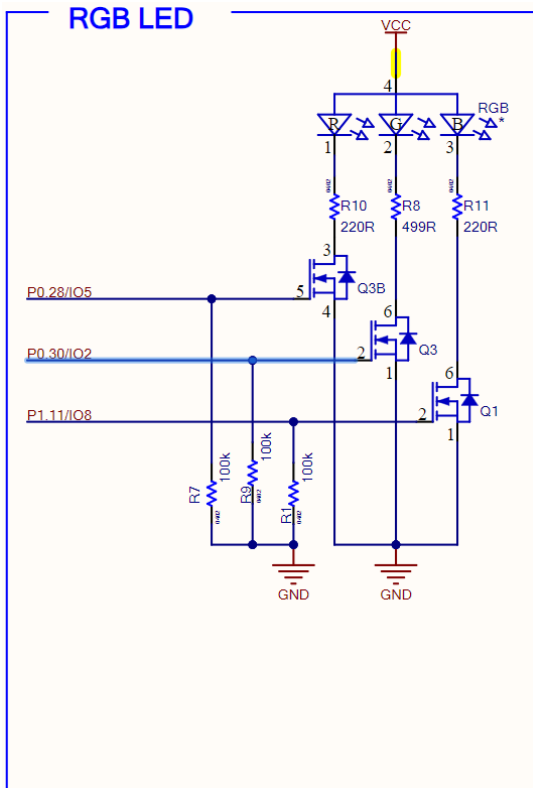

**Figure 16:** RGB LED circuit

The LED functions and pin connections to the NORA-W10 module are described in [Table 8](#).

NORA-W106 pad	ESP32-S3 GPIO	Function
H9	GPIO8 (A)	LED-B
H8	GPIO2 (A)	LED-G
J8	GPIO5 (A)	LED-R

**Table 8:** RGB LED connections

## 2.1.12 Wheel tick and Direction

For automotive applications, Wheel Tick (WT) and Direction (DR) data generated from software or directly from a vehicle sensor can be used to improve Automotive Dead Reckoning (ADR) calculations during instances of weak or no GNSS coverage. WT/DIR data can be communicated from the signal conditioning circuit to the ZED-F9R module through NORA-W1 or directly using an external cable.

Two operational WT/DIR subsystem scenarios showing the interfaces and data flow between the connectors, signal conditioning circuit, NORA-W106 multiradio module, and ZED-F9R GNSS module are shown in [Figure 17](#) and [Figure 18](#). The active components in each scenario are highlighted.

In the first (and most recommended) use scenario shown in [Figure 17](#), an external cable is connected between the two 3-pin headers, J2 (WT/DIR input) and J5 (WT/DIR output). WT/DIR data is communicated to the ZED-F9R module on the GNSS RTK 2 Click board [\[6\]](#) through the cable.

The **WT\_IN** and **DIR\_IN** input signals connect to the signal conditioning circuit through J2. The signal conditioning circuit provides the electrical isolation and switching step-down between the (3.3 V – 24 V) input signals and the standard 3.3 V logic output voltage levels.

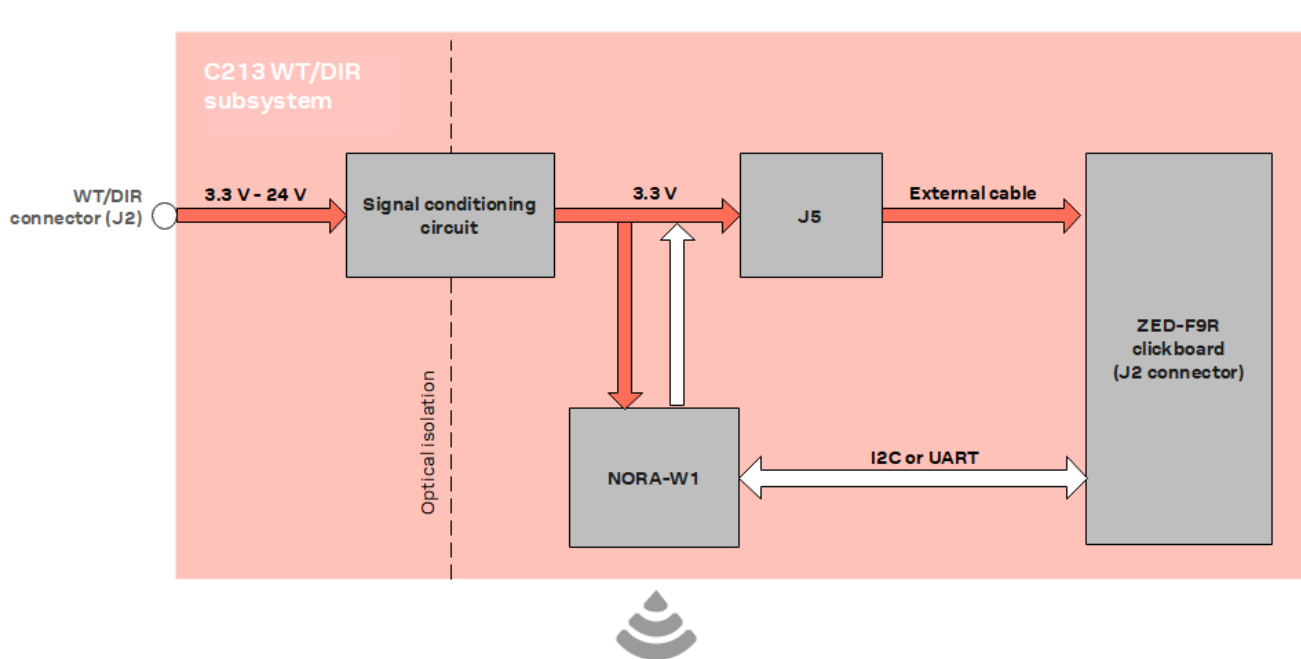

Figure 17: Wheel tick/ Direction flow External cable scenario

In the other use scenario shown in [Figure 18](#), WT/DIR data is communicated to ZED-F9R, without an external cable, through the NORA-W1 multiradio module over the UART (microBUS 1 or 2 only) or I2C interface.

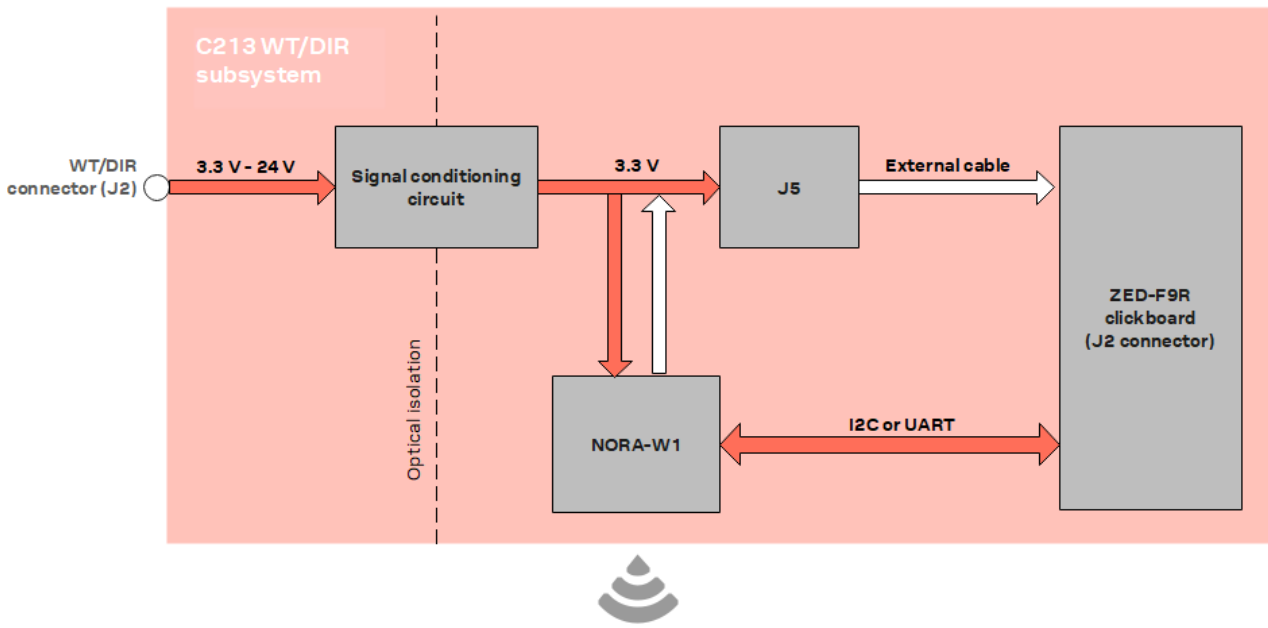

Figure 18: Wheel tick/ Direction flow I2C or UART scenario

The circuit diagram in [Figure 19](#) shows the components and interconnections of the WT/DIR subsystem.

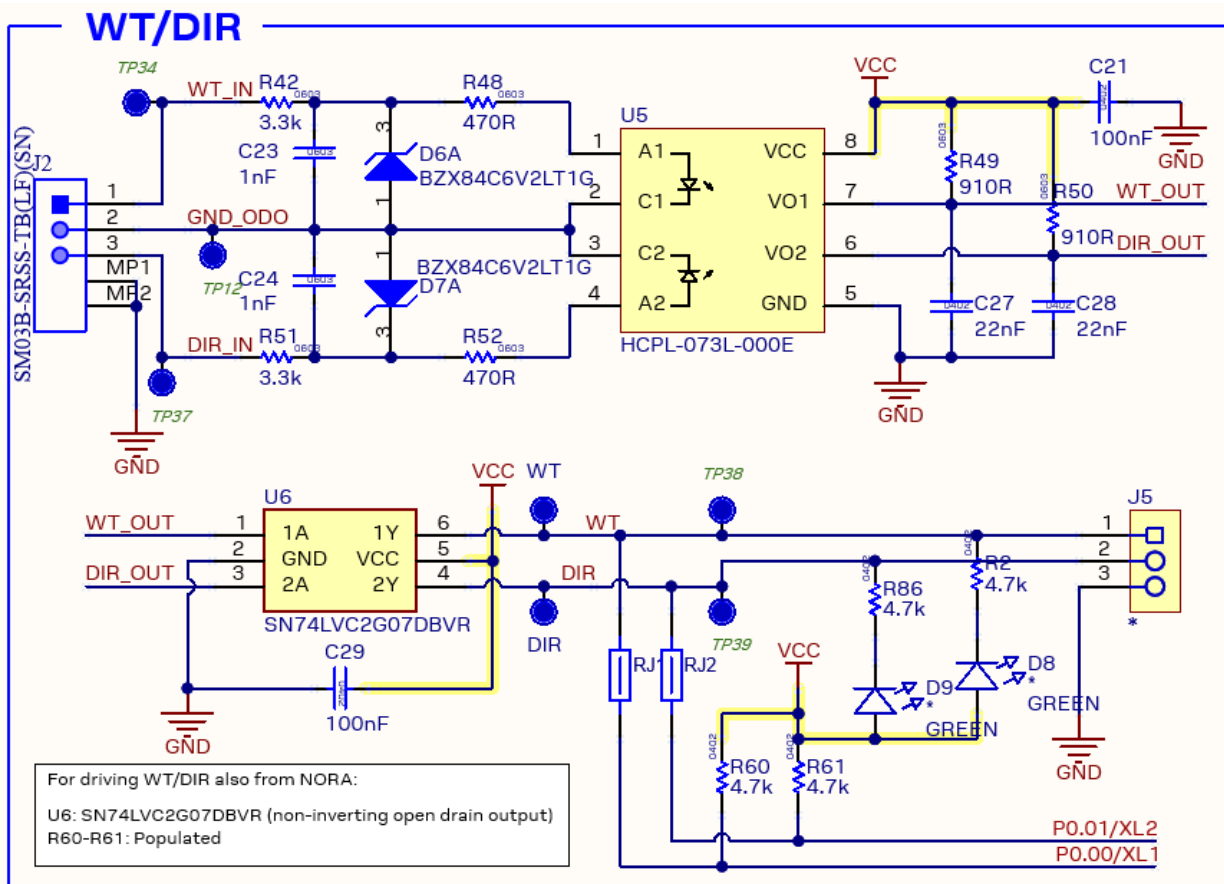

Figure 19: Wheel tick and direction connector (J2) and conditioning circuit

Wheel tick (WT) and direction (DIR) data is communicated from a vehicle sensor to the C213 baseboard through the J2 (JST 1mm pitch 3-pin) connector. The **WT\_IN** and **DIR\_IN** input signals can be monitored on test points TP34 and TP37 and are regulated using two Zener diodes, D6A and D7A. The optocoupler U5 provides the electrical isolation and switching step-down between the external (3.3 V – 24 V) input signals and standard 3.3 V logic output voltage levels, **WT\_OUT** and **DIR\_OUT**.

The conditioning circuit opto-isolates, filters, and then references the signals to 3.3 V using a dual buffer (SN74LVC2G07) in combination with the pull-up resistors, R60 and R61. The circuit prepares the signals for input to the NORA-W106 multiradio module and the GNSS RTK 2 (ZED-F9R) Click board through the J5 header and two wires.

The signal conditioning circuit can also be used with quadrature encoder signals that are input to NORA-W106. The speed/position values can be forwarded to ZED-F9R through the J5 header or can be communicated to it through NORA-W106 over a serial interface (I2C or UART).

The pin connections for the wheel tick and direction signals are shown in [Table 9](#).

NORA-W106 pin	ESP32-S3 GPIO	Function
B6	XTAL_32K_N / GPIO16 (A)	WT/DIR-DIR
C6	XTAL_32K_P / GPIO15 (A)	WT/DIR-WT

Table 9: Wheel tick / direction NORA-W106 signals

## 2.2 Click boards

XPLR-HPG-1 comes with three Click boards:

- GNSS RTK 2 board [\[6\]](#) featuring the ZED-F9R multi-band GNSS module for high-precision GNSS
- LBAND RTK board [\[7\]](#) featuring the NEO-D9S satellite receiver for L-band correction
- 4G LTE 2 board [\[8\]](#) featuring the LARA-R6 LTE Cat 1 cellular module for Internet of Things (IoT) and Machine to Machine (M2M) applications

### 2.2.1 GNSS RTK 2

[Figure 20](#) shows the GNSS RTK 2 Click board hosting the ZED-F9 GNSS module and other main components.

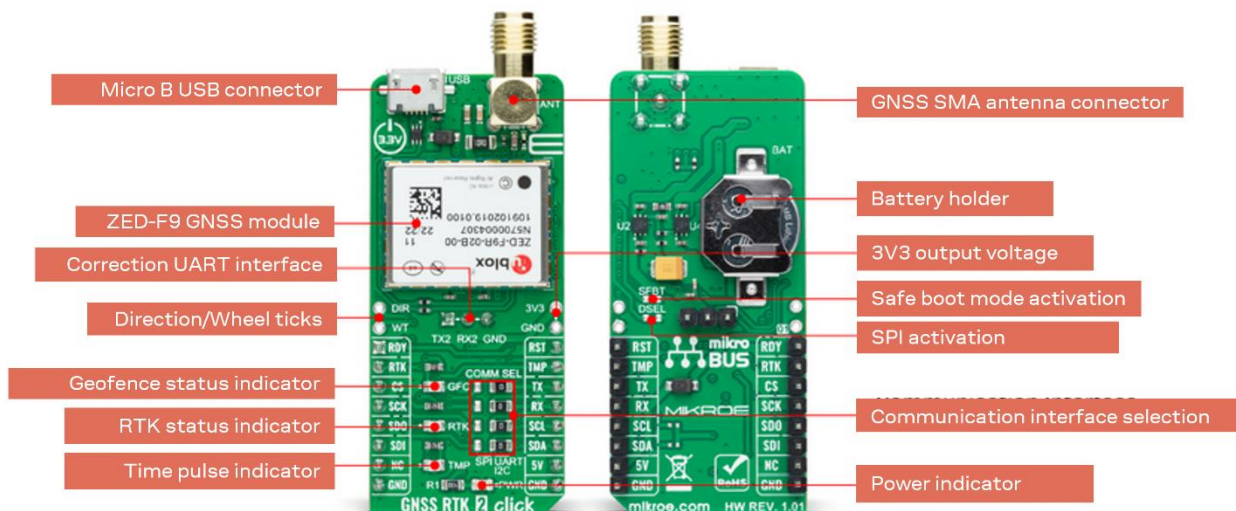

Figure 20: MIKROE GNSS RTK 2 Click board

## 2.2.2 LBAND RTK

Figure 21 shows the LBAND RTK Click board hosting the NEO-D9S module and other main components.

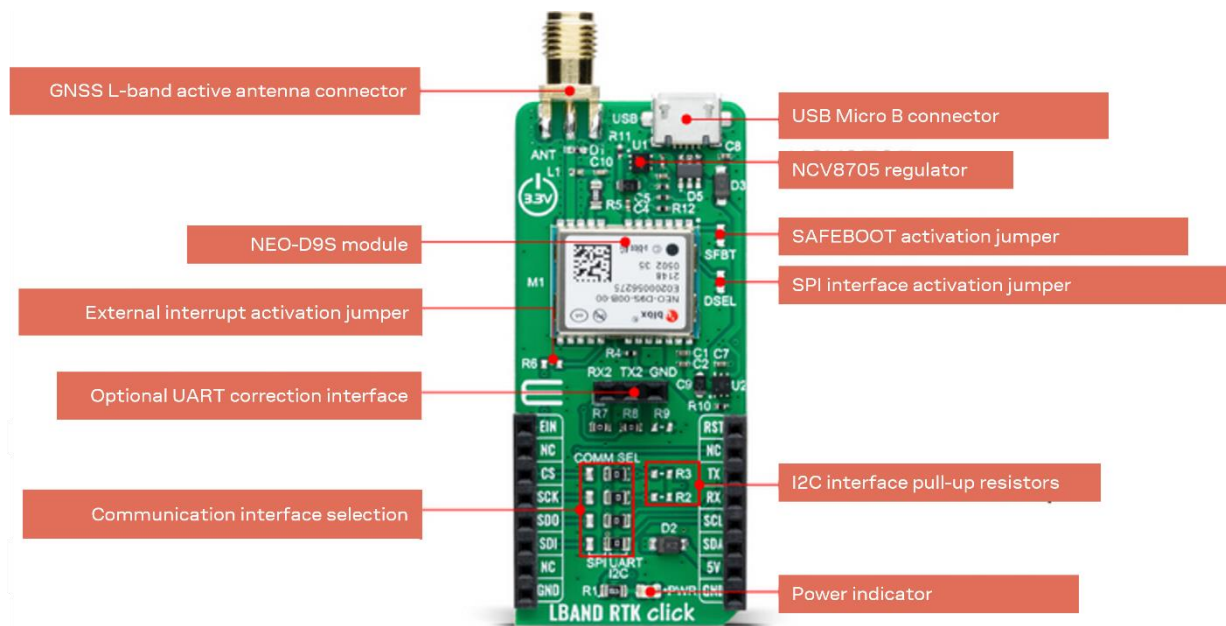

Figure 21: LBAND RTK Click board

## 2.2.3 4G LTE 2

Figure 22 shows the 4G LTE Click board hosting the LARA-R600 module and other main components.

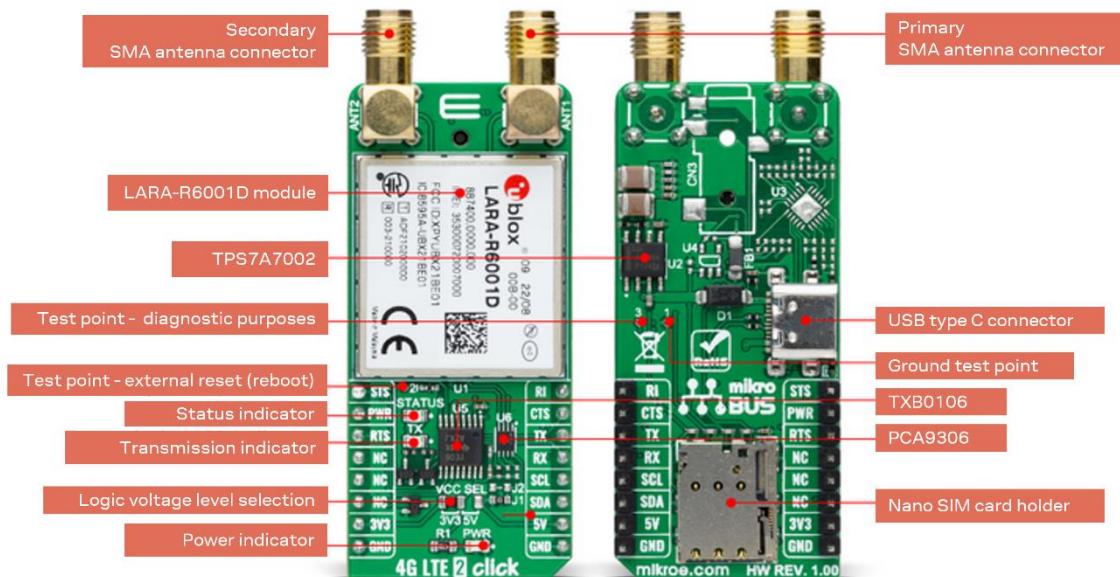

Figure 22: MIKROE 4G LTE 2 Click board

### 3 Software

The XPLR-HPG software available on GitHub operates autonomously, sets the modules according to the chosen use case, handles the different correction data sources, and provides the correction data to the GNSS module. The software includes the HPG library [12], which is built on top of `ubxlib` for tailored, high-precision, GNSS projects.

Figure 23 shows the High Precision GNSS (HPG) data topology for each of the HPG use case examples.

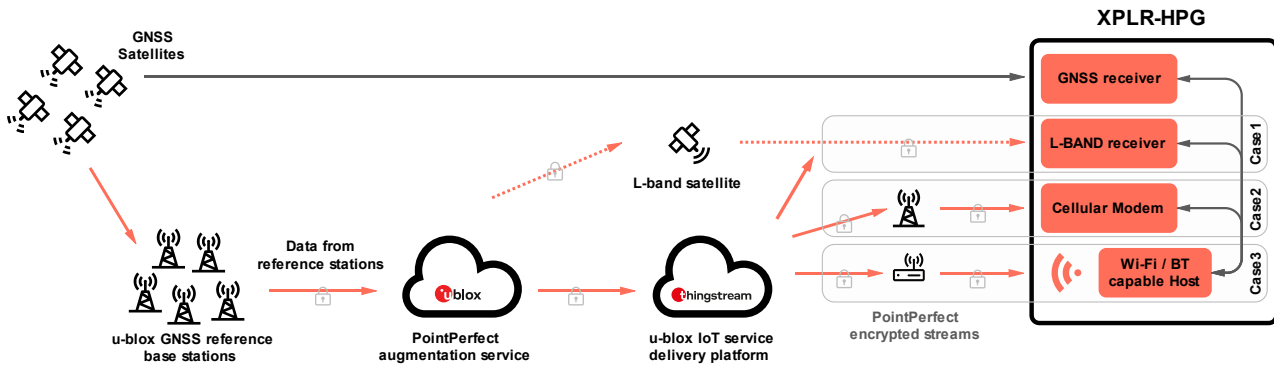

Figure 23: High Precision GNSS data topology showing use case configuration examples

#### 3.1 HPG use case examples

In addition to the HPG library, the HPG software includes several examples that demonstrate the handling of correction data from the u-blox modules in realistic scenarios and use cases, such as:

- Case 1: Correction data over L-band satellite (cell and Wi-Fi)
- Case 2: Correction data over Cellular
- Case 3: Correction data over Wi-Fi

For further information about these and other use cases, see the Examples summary [13].

### 3.2 u-blox library (ubxlib)

HPG software makes use of open-source u-blox library (`ubxlib`), which provides C libraries for connecting the various u-blox modules and building embedded applications easily. The goal of `ubxlib` is to deliver a single tested solution, with examples, which provides uniform easy-to-use APIs across several u-blox products. Releases of `ubxlib` [14] are tested automatically for all configurations on multiple boards in a test farm.

Figure 24 shows how `ubxlib` on the MCU host handles peripheral modules using serial line commands.

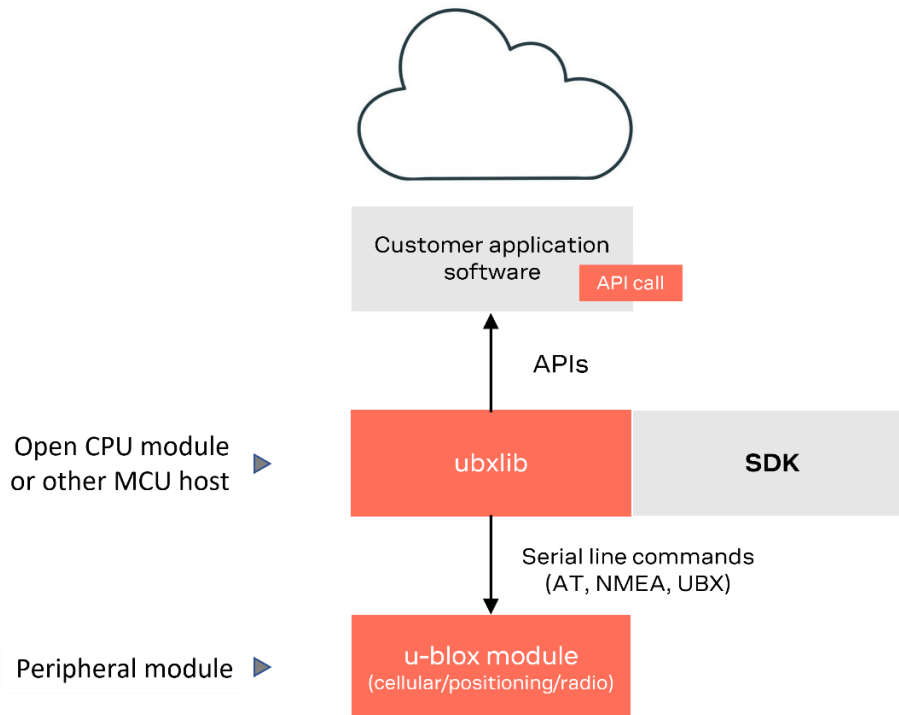

**Figure 24: ubxlib MCU host and peripheral configuration**

`ubxlib` interfaces with most common host SDKs and RTOS to simplify the development of embedded applications for u-blox products and services. The `ubxlib` repository [14] is hosted on GitHub.

The library provides portable, high-level, C libraries that expose the available APIs for handling u-blox short-range radio (Bluetooth/Wi-Fi), positioning (GNSS), and cellular (2G/3G/4G) modules.

`ubxlib` runs on the most common embedded platforms, including u-blox open CPU, stand-alone modules like NORA-B1. For the full list of supported host platforms, refer to the GitHub `ubxlib` repository [14].

## 4 Getting started

The XPLR-HPG-1 explorer kit comes pre-assembled in a Takachi EXPF15-6-11 enclosure – with all Click boards already mounted on the C213 baseboard. Simply [connect the antennas](#) and the kit is ready to use out-of-the-box.

XPLR-HPG-1 does not include a battery or SIM card. As the holders for these components are inaccessible when the kit is fully assembled, you must disassemble the kit to fit them – if needed. See also [Inserting the SIM and battery](#).

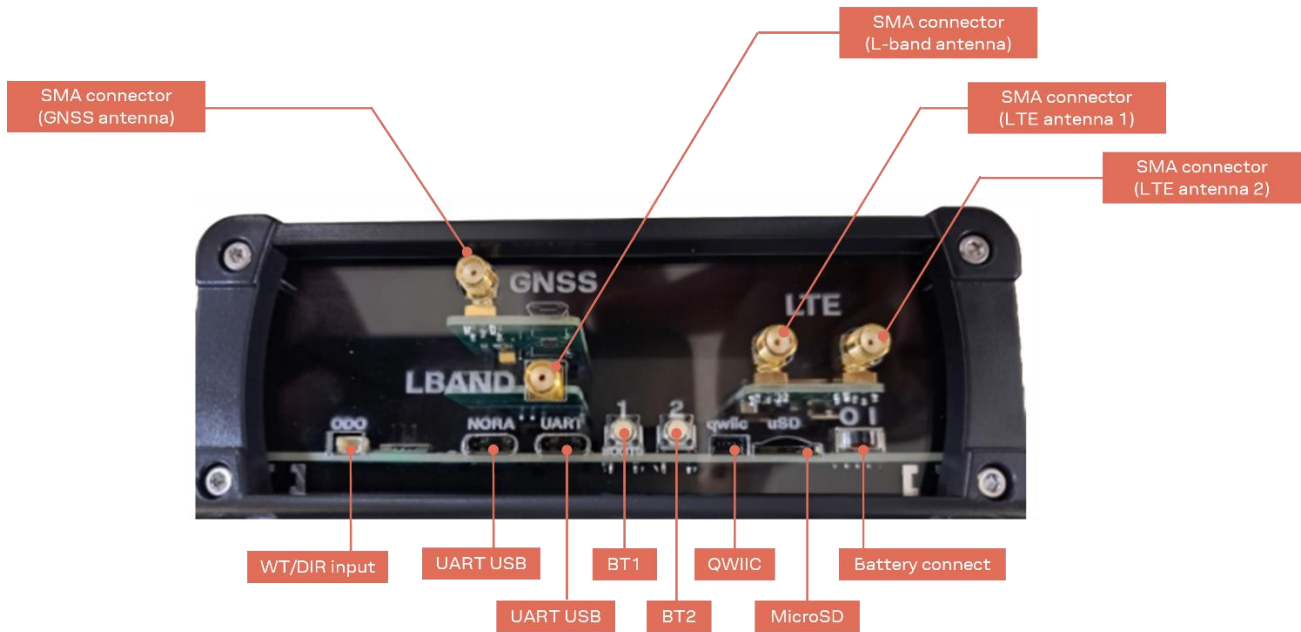

Figure 25: Kit enclosure showing access to antennas, buttons, switches, and connectors

### 4.1 Connecting the antennas

To start using the kit, simply connect the antennas:

1. Connect the L-band antenna to the SMA connector of the LBAND RTK Click board
2. Connect the GNSS antenna to the SMA connector of the GNSS RTK 2 Click board
3. Connect the two LTE antennas to the SMA connectors of the 4G LTE 2 Click board

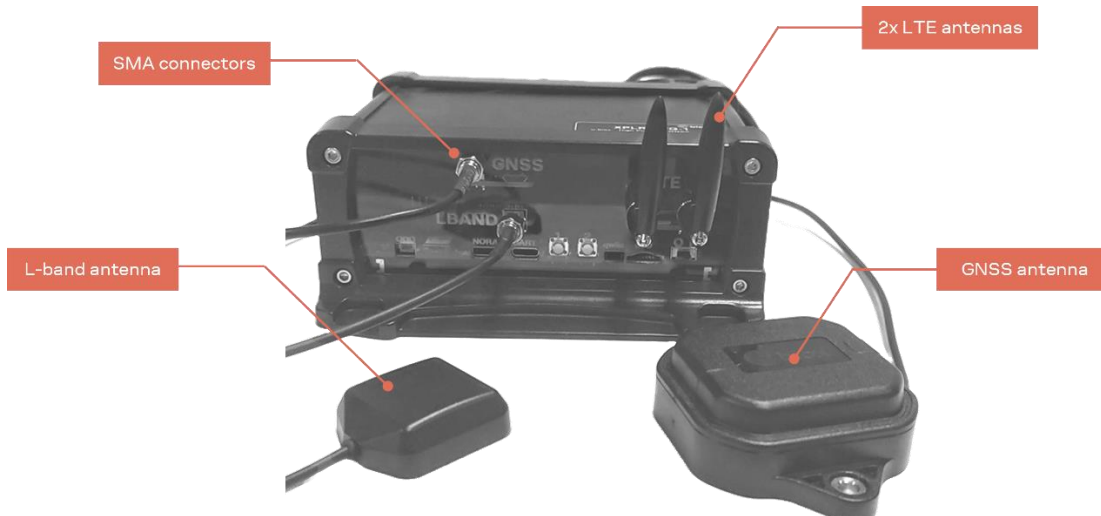

Figure 26: Kit with connected antennas

## 4.2 Inserting the MicroSD card

A MicroSD card (not included in the kit) is only required if you intend to record logfiles from the GNSS RTK 2 Click board. An access hole in the protective plexiglass of the enclosure allows you to plug the card directly into the holder, as shown in [Figure 25](#).

## 4.3 Inserting the SIM and battery

The kit is ready to use out-of-the-box but must be reassembled for:

- Cellular operation – requiring the installation of a SIM card (use case 2)
- Standalone operation – requiring the installation of a battery

If either of these components are required in your application, you must disassemble the kit to fit them.

The following procedure is recommended for fitting these items collectively, but otherwise install only those that are needed for your application design.

1. Make sure that the battery connect switch is OFF (0).
2. Disassemble the Takachi EXPF15-6-11 enclosure as shown in [Assembling the enclosure](#).
3. Remove the 4G LTE 2 Click board from the C213 baseboard.
4. Insert the SIM to the nano card holder on the underside of the 4G LTE 2 Click board.

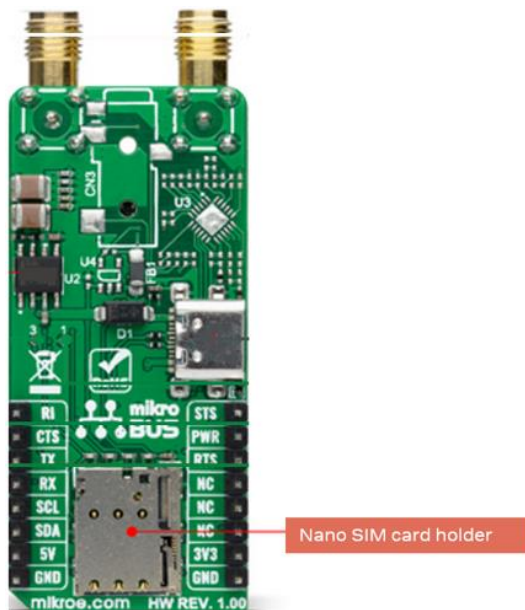

5. Insert the 4G LTE 2 Click board back to the C213 baseboard.
6. Include the 18650 battery in the battery holder, as shown in [Figure 6](#).
7. Assemble the kit again as shown in [Assembling the enclosure](#).

## 4.4 Mounting the Click boards

XPLR-HPG-1 comes pre-assembled in a Takachi EXPF15-6-11 enclosure with all Click boards already mounted on the C213 baseboard. However, if you need to disassemble and reassemble the kit, follow these instructions to mount the Click boards correctly to the C213 baseboard:

1. Prepare GNSS RTK 2 and LBAND RTK (optional for correction data through L-BAND) Click boards
  - a) Stack GNSS RTK 2 Click board on the top of LBAND RTK Click board
  - b) Insert the stacked GNSS RTK 2 and LBAND RTK boards in mikroBUS slot 3.
2. Prepare 4G LTE 2 (LARA-R6) Click board (optional for correction data through LTE)
  - a) Insert a nano SIM (with active data plan) into the card holder on the 4G LTE 2 Click board
  - b) Insert LARA-R6 click board on mikroBUS slot 1.

The C213 baseboard with the mounted Click boards is now ready for assembly into the enclosure. The board configuration is suitable for all [Correction data use cases](#).

Figure 27 shows the GNSS RTK 2 board stacked on the top of LBAND RTK Click board in mikroBUS 3 with the 4G LTE 2 Click Board mounted in mikroBUS 1.

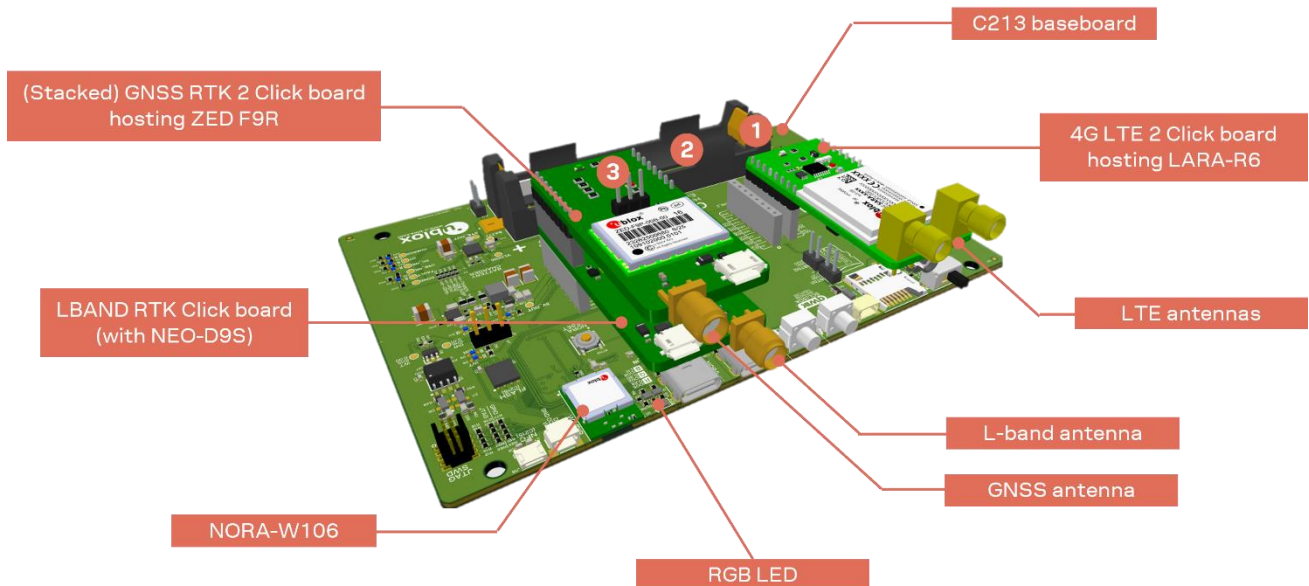

**Figure 27: C213 baseboard with the mounted Click boards ready for assembly**

Two female 1x8-pin header connectors located in parallel with one another on the top side of the LBAND RTK provide the physical interface for stacking the GNSS RTK 2 board.

## 4.5 Assembling the enclosure

The C213 baseboard with mounted Click boards is designed to be inserted in a Takachi EXPF15-6-11 enclosure. To assemble the enclosure:

1. Insert the C213 baseboard with all mounted Click boards into the lowest possible position level of the bottom assembly (item 3). Be sure to include the 18650 battery and the SIM card in their respective positions on the C213 baseboard and the 4G LTE 2 Click board – if needed. These holders are not accessible once the enclosure is fully assembled.
2. Fit the top assembly (item 2) on top of the bottom assembly (item 3)
3. Assemble the back assembly (item 1) and the back frame (item 4) using the four screws (item 7)
4. Assemble the front plexiglass surface (item 6) and front frame (item 8) using the four screws (item 5)

Figure 28 shows the component parts of the enclosure.

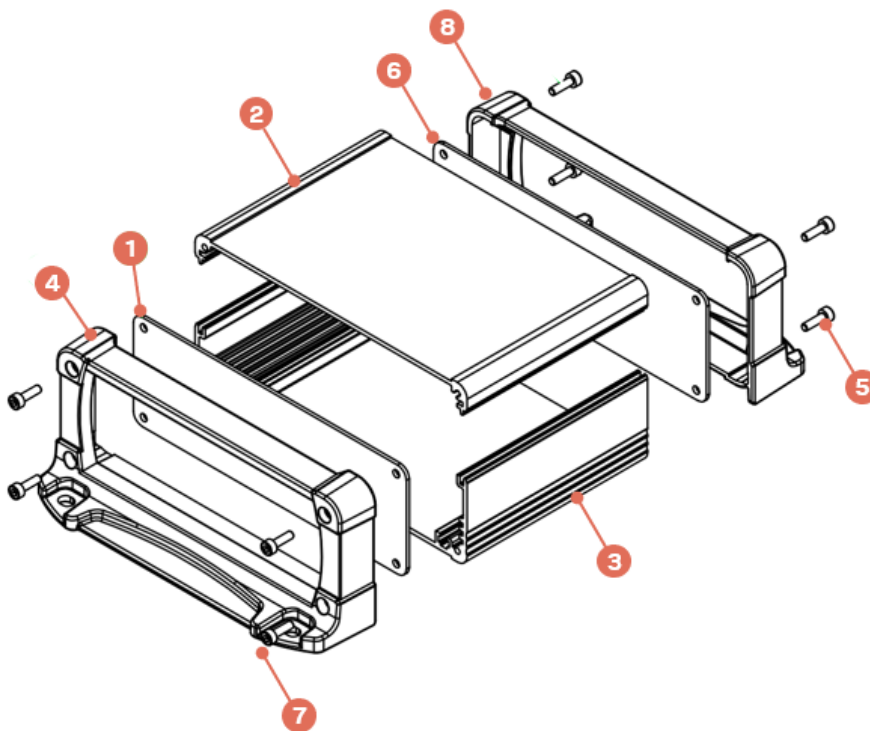

Figure 28: Enclosure parts

Figure 29 shows how the C213 baseboard is seated in the bottom holder of the enclosure.

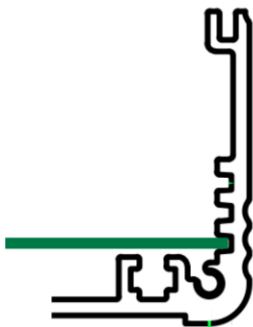

Figure 29: PCB placement in enclosure

## 4.6 Using the kit with the captive web portal

XPLR-HPG-1 includes pre-flashed, captive web portal software that allows access to GNSS correction data from the Thingstream Point Perfect location service over Wi-Fi. Besides provisioning, the web interface also supports a live map-tracking application for visualizing the location of XPLR-HPG-1 in real time. The portal software can be used with [Use case #1](#) and [Use case #3](#).

To start using the XPLR-HPG-1 kit with the captive portal software:

1. Connect the XPLR-HPG-1 board to a computer using a USB-A to USB-C or USB-C to USB-C cable on the UART J6\_2 connector shown in [Figure 6](#).
2. With the kit connected to the computer, NORA-W106 should be available via the “Silicon Labs CP210x UART Bridge” serial interface. Using this COMPORT, you can flash the board and monitor the log messages.
3. Follow the GitHub build instructions for “Live tracking map using a captive portal” [\[17\]](#).

# Appendix

## A Glossary

Abbreviation	Definition
GNSS	Global Navigation Satellite System
GPIO	General-purpose input/output
HPG	High Precision GNSS
I2C	(IIC) Inter Integrated Circuit
LED	Light Emitting Diode
LTE	Long Term Evolution (4G)
MCU	Micro Controller Unit
MQTT	MQ Telemetry Transport
PCB	Printed Circuit Board
PCBA	PCB Assembly
RTK	Real-Time Kinematic
RTOS	Real-Time Operating System
SIM card	Subscriber Identity Module
SMA	Sub Miniature version A connector

**Table 10: Explanation of the abbreviations and terms used**

## Related documentation

- [1] NORA-W10 series, system integration manual, [UBX-22005601](#)
- [2] NORA-W10 series, product page, [\[link\]](#)
- [3] ZED-F9R module, product page, [\[link\]](#)
- [4] NEO-D9S series, product page, [\[link\]](#)
- [5] LARA-R6 series, product page, [\[link\]](#)
- [6] MIKROE GNSS RTK 2 Click board, [\[link\]](#)
- [7] MIKROE LBAND RTK Click board, [\[link\]](#)
- [8] MIKROE 4G LTE 2 Click board, [\[link\]](#)
- [9] Espressif ESP32 documents: Automatic Bootloader, [\[link\]](#)
- [10] mikroE mikroBUS website, [\[link\]](#)
- [11] XPLR-HPG software repository: [Readme.md](#)
- [12] GitHub XPLR-HPG software repository, [HPG library](#)
- [13] GitHub XPLR-HPG software repository, [examples summary](#)
- [14] GitHub repository: [ubxlib](#)
- [15] PointPerfect GNSS augmentation service, [UBX-2102475](#)
- [16] AssistNow A-GNSS services, [UBX-13003352](#)
- [17] Live tracking map using a captive portal - GitHub XPLR-HPG software repository: [Readme](#).
- [18] m-center, [product page](#)
- [19] u-center, [product page](#)

 For product change notifications and regular updates of u-blox documentation, register on our website, [www.u-blox.com](http://www.u-blox.com).

## Revision history

Revision	Date	Name	Comments
R01	01-Nov-2023	tcha	Initial release
R02	05-Apr-2024	aang	Added figure showing the kit with connected antennas in <a href="#">Connecting the antennas</a> , and updated GitHub links to information on the XPLR-HPG software repository. Corrected identification of BTN buttons in <a href="#">Figure 6</a> .
R03	18-Jun-2024	ftor	Added a note about the regulatory limitations in the Document information section.

## Contact

### u-blox AG

Address: Zürcherstrasse 68  
8800 Thalwil  
Switzerland

For further support and contact information, visit us at [www.u-blox.com/support](http://www.u-blox.com/support).