



MAX-M10M-00B

Standard precision GNSS module

Professional grade

Data sheet



Abstract

This data sheet describes the MAX-M10M-00B module, an ultra-low-power GNSS receiver for high-performance asset-tracking applications.

Document information

Title	MAX-M10M-00B	
Subtitle	Standard precision GNSS module	
Document type	Data sheet	
Document number	UBX-22028884	
Revision and date	R04	16-Jan-2026
Disclosure restriction	C1-Public	

Product status	Corresponding content status	
Functional sample	Draft	For functional testing. Revised and supplementary data will be published later.
In development / prototype	Objective specification	Target values. Revised and supplementary data will be published later.
Engineering sample	Advance information	Data based on early testing. Revised and supplementary data will be published later.
Initial production	Early production information	Data from product verification. Revised and supplementary data may be published later.
Mass production / End of life	Production information	Document contains the final product specification.

This document applies to the following products:

Product name	Type number	FW version	IN/PCN reference	Product status
MAX-M10M	MAX-M10M-00B-01	ROM SPG 5.10	UBXDOC-963802114-12186	Mass production

u-blox or third parties may hold intellectual property rights in the products, names, logos and designs included in this document. Copying, reproduction, or modification of this document or any part thereof is only permitted with the express written permission of u-blox. Disclosure to third parties is permitted for clearly public documents only.

The information contained herein is provided "as is" and u-blox assumes no liability for its use. No warranty, either express or implied, is given, including but not limited to, with respect to the accuracy, correctness, reliability and fitness for a particular purpose of the information. This document may be revised by u-blox at any time without notice. For the most recent documents and product statuses, visit www.u-blox.com.

Copyright © 2026, u-blox AG.

Contents

Document information.....	2
Contents.....	3
1 Functional description.....	4
1.1 Overview.....	4
1.2 Performance.....	4
1.3 Supported GNSS constellations.....	5
1.4 Supported protocols.....	6
1.5 Firmware features.....	6
2 Block diagram.....	8
3 Pin definition.....	9
3.1 Pin assignment.....	9
3.2 Pin state.....	10
4 Electrical specifications.....	11
4.1 Absolute maximum ratings.....	11
4.2 Operating conditions.....	11
4.3 Indicative power requirements.....	12
5 Communication interfaces.....	14
5.1 UART.....	14
5.2 I2C.....	14
5.3 Default interface settings.....	16
6 Mechanical specifications.....	17
7 Qualifications and approvals.....	18
8 Product handling.....	19
8.1 Packaging.....	19
8.1.1 Reels.....	19
8.1.2 Tapes.....	19
8.2 Soldering.....	19
9 Product marking and ordering information.....	20
9.1 Product marking.....	20
9.2 Product identifiers.....	20
9.3 Ordering codes.....	21
Related documents.....	22
Revision history.....	23
Contact.....	24

1 Functional description

1.1 Overview

MAX-M10M-00B module features the u-blox M10 standard precision GNSS platform and provides exceptional sensitivity and acquisition time for all L1 GNSS signals.

The M10 platform supports concurrent reception of four GNSSs (GPS, GLONASS, Galileo, and BeiDou). The high number of visible satellites enables the receiver to select the best signals. This maximizes the position availability, in particular under challenging conditions such as in deep urban canyons.

u-blox Super-Signal (Super-S) technology offers great RF sensitivity and can improve the dynamic position accuracy with small antennas or in non-line-of-sight scenarios.

MAX-M10M-00B is cost and power optimized for designs where a SAW filter and an LNA are integrated in the external active antenna. It works in a wide main supply voltage range of 1.8 - 5 V with an extremely low power consumption of less than 10 mW in a 1 Hz cyclic tracking power save mode.

MAX-M10M-00B offers backwards pin-to-pin compatibility with products from the previous u-blox generations, which saves the designer's effort and reduces costs when upgrading designs to the advanced low-power u-blox M10 GNSS technology.

1.2 Performance

Parameter	Specification	Value
Receiver type		u-blox M10 receiver
Accuracy of time pulse signal	RMS	30 ns
	99%	60 ns
Frequency of time pulse signal		Default 1PPS (0.25 Hz to 10 MHz configurable)
Operational limits ¹	Dynamics	≤ 4 g
	Altitude	80,000 m
	Velocity	500 m/s
Velocity accuracy ²		0.05 m/s
Dynamic heading accuracy ²		0.3 deg

Table 1: MAX-M10M-00B specifications

Parameter		GPS+GAL (default)	GPS+GAL +GLO	GPS+GAL +BDS B1I	GPS+GAL +BDS B1C	GPS+GAL +BDS B1C +GLO
Max navigation update rate ³	Default	10 Hz	6 Hz	3 Hz	8 Hz	4 Hz
	High performance ⁴	20 Hz	16 Hz	12 Hz	16 Hz	10 Hz
Position accuracy (CEP) ^{5, 6}		1.5 m	1.5 m	1.5 m	1.5 m	1.5 m

¹ Assuming Airborne 4 g platform.

² 50% at 30 m/s for dynamic operation.

³ Minimum 98% fix rate under typical conditions.

⁴ Configuration required.

⁵ GPS is always in combination with SBAS and QZSS.

Parameter		GPS+GAL (default)	GPS+GAL +GLO	GPS+GAL +BDS B1I	GPS+GAL +BDS B1C	GPS+GAL +BDS B1C +GLO
Time To First Fix (TTFF) ^{5, 7, 8}	Cold start	28 s	23 s	27 s	28 s	23 s
	Hot start	1 s	1 s	1 s	1 s	1 s
	AssistNow Online ⁹	1 s	1 s	1 s	1 s	1 s
	AssistNow Offline ¹⁰	2 s	2 s	3 s	2 s	2 s
	AssistNow Autonomous ¹¹	3 s	4 s	4 s	4 s	4 s
Sensitivity ¹²	Tracking and navigation	-165 dBm	-167 dBm	-162 dBm	-163 dBm	-163 dBm
	Reacquisition	-160 dBm	-160 dBm	-160 dBm	-160 dBm	-160 dBm
	Cold Start	-148 dBm	-148 dBm	-148 dBm	-148 dBm	-148 dBm
	Hot start ⁷	-159 dBm	-159 dBm	-159 dBm	-159 dBm	-159 dBm

Table 2: MAX-M10M-00B typical performance in multi-constellation GNSS modes.

Parameter		GPS	GLONASS	BDS B1I	GALILEO	BDS B1C
Max navigation update rate ³	Default	18 Hz	18 Hz	18 Hz	18 Hz	18 Hz
	High performance ⁴	25 Hz	25 Hz	25 Hz	25 Hz	25 Hz
Position accuracy (CEP) ^{5, 6}		1.5 m	4 m	2 m	3 m	2 m
Time To First Fix (TTFF) ^{5, 7, 8}	Cold start	29 s	27 s	30 s	41 s	58 s
	Hot start	1 s	1 s	1 s	1 s	1 s
	AssistNow Online ⁹	1 s	1 s	2 s	7 s	N/A
Sensitivity ¹²	Tracking and navigation	-165 dBm	-165 dBm	-159 dBm	-157 dBm	-159 dBm
	Reacquisition	-160 dBm	-158 dBm	-158 dBm	-155 dBm	-156 dBm
	Cold Start	-148 dBm	-147 dBm	-144 dBm	-139 dBm	-134 dBm
	Hot start ⁷	-159 dBm	-159 dBm	-159 dBm	-155 dBm	-157 dBm

Table 3: MAX-M10M-00B typical performance in single-GNSS modes

1.3 Supported GNSS constellations

MAX-M10M-00B is a concurrent GNSS receiver that can receive and track multiple GNSS systems. To achieve lower power consumption, the receiver can be configured for a subset of GNSS constellations.

The default configuration on MAX-M10M-00B is concurrent reception of GPS and Galileo with QZSS and SBAS enabled.

The following GNSS and their signals are supported:

System	Signals
GPS / QZSS	L1C/A (1575.42 MHz)
Galileo	E1-B/C (1575.42 MHz)

⁶ CEP, 50%, 24 hours static, -130 dBm, > 6 SVs for each GNSS system.

⁷ Commanded starts.

⁸ All satellites at -130 dBm. Measured at room temperature.

⁹ Dependent on the speed and latency of the aiding data connection, commanded starts.

¹⁰ Using seven days old AssistNow Offline data. External memory may be required.

¹¹ Using two days old orbital predicted data. External memory may be required.

¹² Demonstrated with a good external LNA. Measured at room temperature.

System	Signals
GLONASS	L1OF (1602 MHz + k*562.5 kHz, k = -7,..., 5, 6)
BeiDou ¹³	B1I (1561.098 MHz), B1C (1575.42 MHz)

Table 4: Supported GNSS and signals on MAX-M10M-00B

The following GNSS assistance services are supported:

Service	Support
AssistNow Live Orbits	GPS L1C/A, Galileo E1, QZSS L1C/A, GLONASS L1OF, BeiDou B1I
AssistNow Predictive Orbits	GPS L1C/A, Galileo E1, GLONASS L1OF
AssistNow Autonomous	GPS L1C/A, Galileo E1, GLONASS L1OF, QZSS L1C/A, BeiDou B1I

Table 5: Supported Assisted GNSS (A-GNSS) services

The following augmentation systems are supported:

System	Support
SBAS	EGNOS, GAGAN, MSAS, WAAS, BDSBAS, KASS and SouthPAN
QZSS	L1S (SLAS)

Table 6: Supported augmentation systems

The SBAS and QZSS augmentation systems can be enabled only if GPS operation is also enabled.

1.4 Supported protocols

MAX-M10M-00B supports the following interface protocols:

Protocol	Type
UBX	Input/output, binary, u-blox proprietary
NMEA versions 2.1, 2.3, 4.0, 4.10 and 4.11 (default)	Input/output, ASCII

Table 7: Supported protocols

1.5 Firmware features

Feature	Description
Antenna supervisor ¹⁴	Antenna supervisor for active antenna control and short detection
CloudLocate GNSS	Extends the life of energy-constrained IoT applications. Small payload messages supported.
Assisted GNSS	AssistNow Live Orbits, AssistNow Predictive Orbits, and AssistNow Autonomous
Backup modes	Hardware backup mode and software standby mode
Power save modes	On/off, cyclic tracking
Super-S	Improved accuracy with small antennas
Galileo return link messages	Galileo search and rescue (SAR) return link messages (RLM) via Galileo satellite signal
Data batching	Stores position/velocity/time information over up to 10 min in RAM without host interaction

¹³ BeiDou B1I cannot be enabled simultaneously with BeiDou B1C or GLONASS L1OF.

¹⁴ External components required, some pins need to be reconfigured.

Feature	Description
Odometer	Measures traveled distance with support for different user profiles

Table 8: Firmware features

Feature	Description
Anti-jamming	RF interference and jamming detection and reporting
Anti-spoofing	Spoofing detection and reporting
Configuration lockdown	Receiver configuration can be locked by command
Message integrity	All messages can be cryptographically signed
Secure boot	Only signed firmware images are executed

Table 9: Security features

2 Block diagram

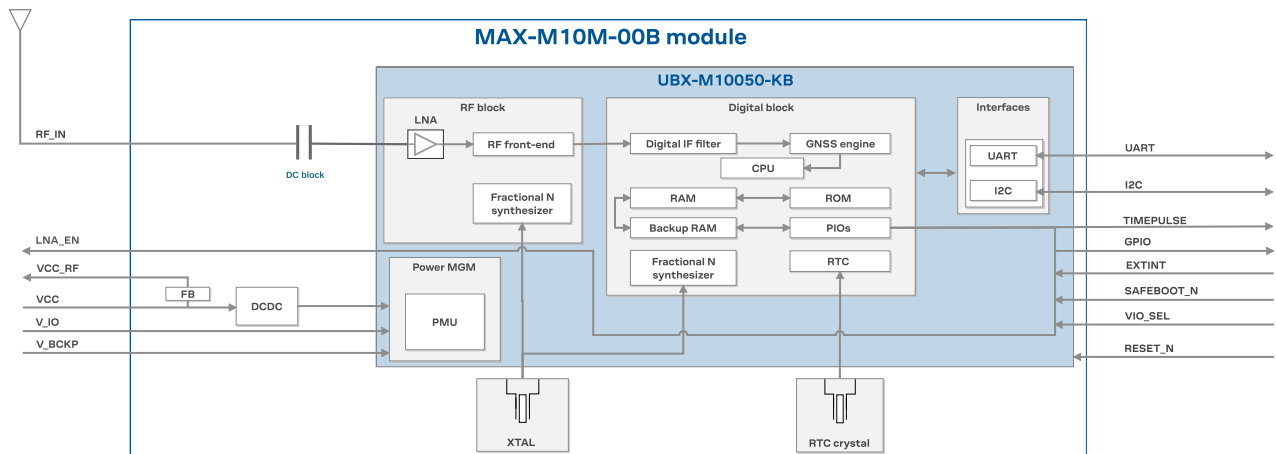

Figure 1: MAX-M10M-00B block diagram

3 Pin definition

3.1 Pin assignment

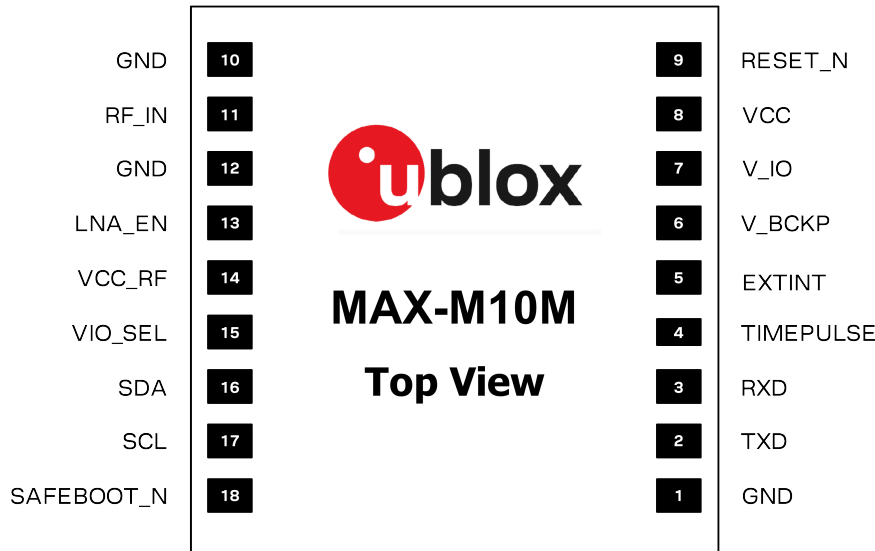

Figure 2: MAX-M10M-00B pin assignment

Pin no.	Name	PIO no.	I/O	Description
1	GND	-	-	Connect to GND
2	TXD	1	O	UART TX. Leave open if not used.
3	RXD	0	I	UART RX. Leave open if not used.
4	TIMEPULSE	4	O	Time pulse signal (shared with SAFEBOOT_N pin) ¹⁵
5	EXTINT	5	I	External interrupt. Leave open if not used.
6	V_BCKP	-	I	Backup voltage supply
7	V_IO	-	I	IO voltage supply
8	VCC	-	I	Main voltage supply
9	RESET_N	-	I	System reset (active low). Has to be low for at least 1 ms to trigger a reset.
10	GND	-	-	Connect to GND
11	RF_IN	-	I	GNSS signal input
12	GND	-	-	Connect to GND
13	LNA_EN	-	O	On/Off external LNA or active antenna
14	VCC_RF	-	O	Output voltage RF section
15	VIO_SEL	-	I	Voltage selector for V_IO supply. Connect to GND for 1.8 V supply, or leave open for 3.3 V supply.
16	SDA	2	I/O	I2C data. Leave open if not used
17	SCL	3	I	I2C clock. Leave open if not used.
18	SAFEBOOT_N	-	I	Safeboot mode (active low). Leave open if not used. ¹⁵

Table 10: MAX-M10M-00B pin assignment

¹⁵ The receiver enters safeboot mode if this pin is low at start up. The SAFEBOOT_N pin is internally connected to TIMEPULSE pin through a 1 kΩ series resistor.

3.2 Pin state

Table 11 defines the state of the PIOs and RESET_N pins in different modes. The functions of the PIOs are as defined in the default configuration.

PIO no.	Pin no.	Default function	Continuous mode	Software standby mode	Safe boot mode
0	3	RXD	Input pull-up	Input pull-up	Input pull-up
1	2	TXD	Output	Input pull-up	Output
2	16	SDA	Input pull-up	Input pull-up	Input pull-up
3	17	SCL	Input pull-up	Input pull-up	Input pull-up
4 ¹⁵	18	SAFEBOOT_N	Output	Input pull-up	Output (low)
	4	TIMEPULSE	Output	Input pull-up	Output (low)
5	5	EXTINT	Input pull-up	Input pull-up	Input pull-up
7	13	LNA_EN	Output (high)	Input pull-down	Input pull-up
-	9	RESET_N	Input pull-up	Input pull-up	Input pull-up

Table 11: Pin state



In reset mode (RESET_N = low), all PIOs are configured as input pull-up.



In hardware backup mode (VCC = 0 V and V_IO = 0 V), PIOs must not be driven.

4 Electrical specifications

4.1 Absolute maximum ratings

- CAUTION. Risk of device damage. Exceeding the absolute maximum ratings may affect the lifetime and reliability of the device or permanently damage it. Do not exceed the absolute maximum ratings.
- This product is not protected against overvoltage or reversed voltages. Use appropriate protection to avoid device damage from voltage spikes exceeding the specified boundaries.

Symbol	Parameter	Min	Max	Unit
VCC	Main supply voltage	-0.3	6	V
V _{IO}	IO supply voltage, V _{IO_SEL} = GND	-0.3	1.98	V
	IO supply voltage, V _{IO_SEL} = open	-0.3	3.6	V
	Voltage ramp on V _{IO} ¹⁶	25	35000	μs/V
V _{BCKP}	Backup supply voltage	-0.3	3.6	V
V _{PIO}	Input voltage on RESET_N and digital pins V _{IO_SEL} = GND	-0.3	V _{IO} + 0.3 (max 1.98)	V
	Input voltage on RESET_N and digital pins V _{IO_SEL} = open	-0.3	V _{IO} + 0.3 (max 3.6)	V
I _{PIO}	Max source / sink current, digital pins ¹⁷	-10	10	mA
ICC _{RF}	Max source current, VCC _{RF}		250	mA
V _{DC_{rfin}}	DC voltage at RF_IN	-5.5	+5.5	V
P _{rfin}	RF input power at RF_IN ¹⁸		+15	dBm
T _{amb}	Ambient temperature	-40	+85	°C
T _s	Storage temperature	-40	+85	°C

Table 12: Absolute maximum ratings

4.2 Operating conditions

Table 13 shows the general operating conditions. Table 14 shows the electrical parameters for digital I/O.

- The V_{IO} voltage range is selected with the V_{IO_SEL} pin.
- For designs with 1.8 V supply at V_{IO} and V_{BCKP} supplied, switch off the V_{IO} supply 100 ms before VCC when transitioning to the hardware backup mode. Alternatively, put the receiver to software standby mode by sending the UBX-RXM-PMREQ message before switching off V_{IO} and VCC. For designs with 3 V supplies, both supplies can be switched off simultaneously. Alternatively, switch off V_{IO} before VCC.

Symbol	Parameter	Min	Typical	Max	Unit
VCC	Main supply voltage	1.76	1.8, 3.3	5.5	V
V _{IO}	IO supply voltage, V _{IO_SEL} = GND	1.68	1.8	1.98	V
	IO supply voltage, V _{IO_SEL} = open	2.7	3.3	3.6	V

¹⁶ Exceeding the voltage ramp speed may permanently damage the device.

¹⁷ The SAFEBOOT_N pin has an internal 1 kΩ series resistor.

¹⁸ Test conditions: source impedance = 50 Ω, continuous wave.

Symbol	Parameter	Min	Typical	Max	Unit
V_BCKP	Supply voltage, backup domain	1.65		3.6	V
V_IO _{SWITCH}	V_IO voltage threshold to switch an internal supply for the backup domain from V_IO to V_BCKP		1.45		V
VCC_RF	VCC_RF output voltage		VCC - 0.1		V
ICC_RF	VCC_RF output current			50	mA
Z _{in} ¹⁹	Input impedance at RF_IN		50		Ω
NF _{tot}	Receiver chain noise figure		3.5		dB
Ext_gain ²⁰	External gain at RF_IN, normal gain mode (default)			40	dB
	External gain at RF_IN, low gain mode	14		50	dB
	External gain at RF_IN, bypass mode	23		60	dB
T _{opr}	Operating temperature	-40		+85	°C

Table 13: General operating conditions

Symbol	Parameter	Min	Typical	Max	Unit
I _{leak}	Leakage current input pins ²¹		25		nA
V _{in}	Input pin voltage range	0		V_IO	V
V _{il}	Low-level input voltage			0.63	V
V _{ih}	High-level input voltage	0.68 x V_IO			V
V _{ol}	Low-level output voltage, I _{out} = -2 mA ²²			0.4	V
V _{oh}	High-level output voltage, I _{out} = 2 mA ²²	V_IO - 0.4			V
R _{pu, IO}	Pull-up resistance, Digital IO ²³ . V_IO_SEL = GND	6	17	72	kΩ
R _{pu, IO}	Pull-up resistance, Digital IO ²³ . V_IO_SEL = open	8	18	40	kΩ
R _{pd, IO}	Pull-down resistance, Digital IO	21	80	180	kΩ
R _{pu, SAFEBOOT_N}	Pull-up resistance, SAFEBOOT_N ²⁴	6	17	72	kΩ
R _{pu, RESET_N}	Pull-up resistance, RESET_N	7	10	13	kΩ

Table 14: Digital IO

4.3 Indicative power requirements

This section provides examples of typical current requirements. They are characterized on samples using a cold start command. The actual power requirements may vary depending on the firmware version used, the external circuitry, the number of satellites tracked, the signal strength, the type and time of start, duration, internal LNA gain mode, and the test conditions.

All values in [Table 15](#), [Table 16](#), and [Table 17](#) have been measured at 25 °C ambient temperature with the default configuration unless otherwise stated. SBAS and QZSS are active in all measurements.

[Table 15](#) shows indicative current consumption for VCC and V_IO with a 3.0 V supply.

¹⁹ The RF_IN input integrates a built-in DC block.

²⁰ The internal LNA gain is configurable.

²¹ V_{in} = V_IO, at room temperature.

²² TIMEPULSE (PIO4) has 4 mA current drive/sink capability.

²³ TXD, RXD, TIMEPULSE, EXTINT, SCL, SDA, and LNA_EN.

²⁴ The SAFEBOOT_N pin has an additional 1 kΩ series resistor.

Symbol (Parameter)	Conditions	GPS	GPS+GAL (default)	GPS+GAL +GLO	GPS+GAL +BDS B1I	GPS+GAL +BDS B1C	GPS+GAL +BDS B1C +GLO	Unit
$I_{VCC}^{25, 26}$ (Current at VCC)	Acquisition ²⁷	6	8	10	9.5	9	11	mA
	Tracking (Continuous mode)	5	5.5	6.5	7	6	7.5	mA
	Tracking (Power save mode) ²⁸	2	2.1	2.5	2.5	-	-	mA
$I_{V_{IO}}^{25}$ (Current at V _{IO})	Acquisition and Tracking (Continuous mode)	1.7	1.7	1.8	1.7	1.7	1.8	mA
	Tracking (Power save mode) ²⁸	1.5	1.5	1.5	1.5	-	-	mA

Table 15: Typical currents for 3.0 V supply at VCC and V_{IO}

Table 16 shows indicative current consumption for VCC and V_{IO} with a 1.8 V supply.

Symbol (Parameter)	Conditions	GPS	GPS+GAL (default)	GPS+GAL +GLO	GPS+GAL +BDS B1I	GPS+GAL +BDS B1C	GPS+GAL +BDS B1C +GLO	Unit
$I_{VCC}^{25, 26}$ (Current at VCC)	Acquisition ²⁷	10	13.5	16	15.5	15	18	mA
	Tracking (Continuous mode)	8	9	11	11.5	10	12	mA
	Tracking (Power save mode) ²⁸	3.2	3.5	4.2	4.2	-	-	mA
$I_{V_{IO}}^{25}$ (Current at V _{IO})	Acquisition and Tracking (Continuous mode)	1.7	1.7	1.8	1.7	1.7	1.8	mA
	Tracking (Power save mode) ²⁸	1.5	1.5	1.5	1.5	-	-	mA

Table 16: Typical currents for 1.8 V supply at VCC and V_{IO}

The inrush current can go up to 100 mA at startup. Ensure that the external power supply is able to deliver up to 100 mA.

Table 17 shows current consumption for the backup modes.

Symbol	Parameter	Conditions	Typ.	Unit
$I_{V_{BCKP}}^{29}$	Total current in hardware backup mode	V _{BCKP} = 3.3 V, V _{IO} = VCC = 0 V	28	μA
$I_{V_{IO}}$	V _{IO} current in software standby mode	V _{IO} = 1.8 V	37	μA
		V _{IO} = 3.3 V	46	μA
I_{VCC}	VCC current in software standby mode	VCC = 3.3 V	120	nA

Table 17: Backup currents

Extreme operating temperatures can significantly impact the specified values. If an application operates near the min or max temperature limits, ensure the specified values are not exceeded.

²⁵ 1 Hz navigation update rate.

²⁶ Internal LNA set to normal gain. Simulated signal using power levels of -130 dBm.

²⁷ Average current from start-up until the first fix.

²⁸ Cyclic tracking operation. BeiDou B1C is not supported in this mode.

²⁹ $I_{V_{BCKP}}$ current in normal operation (V_{BCKP} = 3.3 V, V_{IO} = VCC = 3.3V) is ~3 μA.

5 Communication interfaces

The receiver supports communication over the UART and I2C interfaces.

All the inputs have an internal pull-up resistor in normal operation and can be left open if not used. The voltage level at the PIO pins is related to the V_{IO} supply voltage.

5.1 UART

The UART interface supports configurable baud rates. Hardware flow control is not supported. UART specifications are described in [Table 18](#).

Symbol	Parameter	Min	Max	Unit
R _u	Baud rate	9600	921600	bit/s
Δ _{Tx}	Tx baud rate accuracy	-1%	+1%	-
Δ _{Rx}	Rx baud rate tolerance	-2.5%	+2.5%	-

Table 18: UART specifications

5.2 I2C

An I2C interface is available for communication with an external host CPU in the I2C Fast-mode. Backwards compatibility with the Standard-mode I2C bus operation is not supported. The interface can be operated only in the peripheral mode with a maximum clock frequency of 400 kHz³⁰.

The interface can make use of clock stretching by holding the SCL line LOW to pause a transaction. In this case, the bit transfer rate is reduced. The maximum clock stretching time is 20 ms.

³⁰ External pull-up resistors may be needed to achieve 400 kbit/s communication speed, as the internal pull-up resistance can be very large.

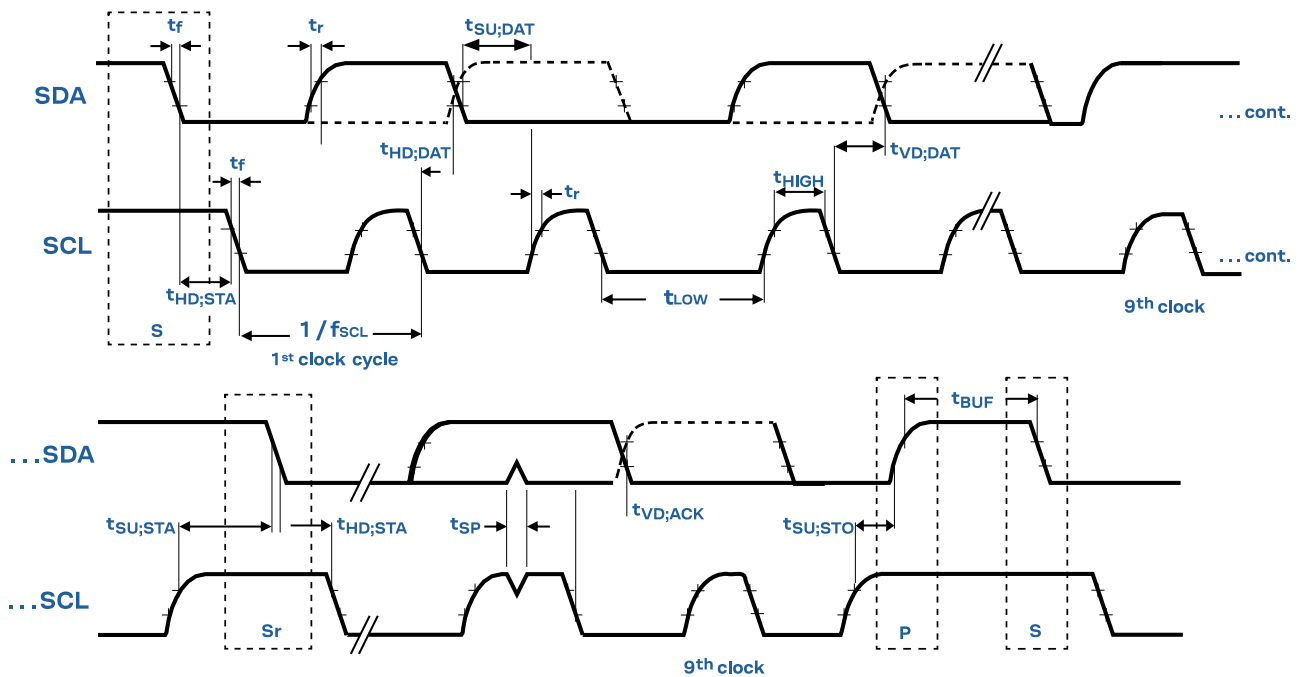

$$V_{IL} = 0.3 V_{DD}$$

$$V_{IH} = 0.7 V_{DD}$$

Figure 3: I2C peripheral specification

Symbol	Parameter	I2C Fast-mode		Unit
		Min	Max	
f_{SCL}	SCL clock frequency	0	400	kHz
$t_{HD;STA}$	Hold time (repeated) START condition	0.6	-	μ s
t_{LOW}	Low period of the SCL clock	1.3	-	μ s
t_{HIGH}	High period of the SCL clock	0.6	-	μ s
$t_{SU;STA}$	Setup time for a repeated START condition	0.6	-	μ s
$t_{HD;DAT}$	Data hold time	0 ³¹	_ ³²	μ s
$t_{SU;DAT}$	Data setup time	100	-	ns
t_r	Rise time of both SDA and SCL signals	-	300 (for C = 400pF)	ns
t_f	Fall time of both SDA and SCL signals	-	300 (for C = 400pF)	ns
$t_{SU;STO}$	Setup time for STOP condition	0.6	-	μ s
t_{BUF}	Bus-free time between a STOP and START condition	1.3	-	μ s
$t_{VD;DAT}$	Data valid time	-	0.9 ³²	μ s
$t_{VD;ACK}$	Data valid acknowledge time	-	0.9 ³²	μ s
V_{nL}	Noise margin at the low level	0.1 V_{IO}	-	V

³¹ External device must provide a hold time of at least one transition time (max 300 ns) for the SDA signal (with respect to the min V_{ih} of the SCL signal) to bridge the undefined region of the falling edge of SCL.

³² The maximum $t_{HD;DAT}$ must be less than the maximum $t_{VD;DAT}$ or $t_{VD;ACK}$ with a maximum of 0.9 μ s by a transition time. This maximum must only be met if the device does not stretch the LOW period (t_{LOW}) of the SCL signal. If the clock stretches the SCL, the data must be valid by the set-up time before it releases the clock.

Symbol	Parameter	I2C Fast-mode		Unit
		Min	Max	
V _{nH}	Noise margin at the high level	0.2 V _{IO}	-	V

Table 19: MAX-M10M-00B I2C peripheral timing and specifications

5.3 Default interface settings

Interface	Settings
UART	<ul style="list-style-type: none"> 9600 baud, 8 bits, no parity bit, 1 stop bit. Input messages: NMEA and UBX Output messages: NMEA GGA, GLL, GSA, GSV³³, RMC, VTG and TXT
I2C	<ul style="list-style-type: none"> 7-bit I2C address (0x42). Input messages: NMEA and UBX Output messages: NMEA GGA, GLL, GSA, GSV³³, RMC, VTG and TXT

Table 20: Default interface settings

³³ In the default configuration, the NMEA-GSV messages are sent at 5-second intervals to avoid overflow in the TX buffer.

6 Mechanical specifications

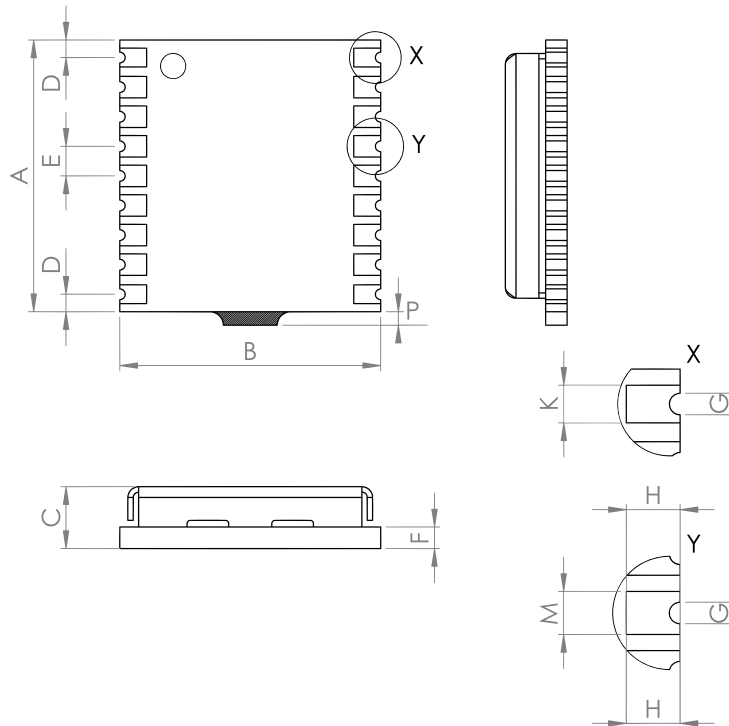

Figure 4: MAX-M10M-00B mechanical drawing

Symbol	Min (mm)	Typical (mm)	Max (mm)
A	10.0	10.1	10.7
B	9.6	9.7	9.8
C	2.2	2.5	2.7
D	0.55	0.65	0.95
E	1.0	1.1	1.2
F	-	0.76	-
G	0.3	0.4	0.5
H	0.9	1.0	1.1
K	0.6	0.7	0.8
M	0.7	0.8	0.9
P	0.0	0.3	0.6
Weight		0.5 g	

Table 21: MAX-M10M-00B mechanical dimensions

- The mechanical picture of the de-paneling residual tab (P) is an approximate representation, shape and position may vary.
- Take the size of the de-paneling residual tabs into account when designing the component keepout area.
- The width (K) applies to all four corner pins.
- The pitch (E) applies to all pins.

7 Qualifications and approvals

Type	Description
Quality and reliability	
Product qualification	Qualified according to u-blox qualification policy, based on a subset of AEC-Q104
Manufacturing	Manufactured at IATF 16949 certified sites
Environmental	
RoHS compliance	Yes
Moisture sensitivity level (MSL) ^{34, 35}	4
Type approvals	
European RED certification (CE)	Declaration of Conformity (DoC) is available on the u-blox website .
UK conformity assessment (UKCA)	Yes

Table 22: Qualifications and approvals

³⁴ For MSL standard see IPC/JEDEC J-STD-020 and J-STD-033 [5].

³⁵ For more information regarding moisture sensitivity levels, labeling, storage, and drying, see the Product packaging reference guide [4].

8 Product handling

8.1 Packaging

The MAX-M10M-00B modules are delivered as hermetically sealed, reeled tapes to enable efficient production, production lot set-up and tear-down. For more information, see the Product packaging reference guide [4].

8.1.1 Reels

MAX-M10M-00B modules are deliverable in quantities of 500 pieces on a reel. They are shipped on reel type B1, as specified in the Product packaging reference guide [4].

8.1.2 Tapes

The feed direction into the pick and place pick-up is from the reel (located on the left of the figure) towards right, and the tape is fed to the right.

The dimensions of the tape are specified in Figure 5 (measurements in mm).

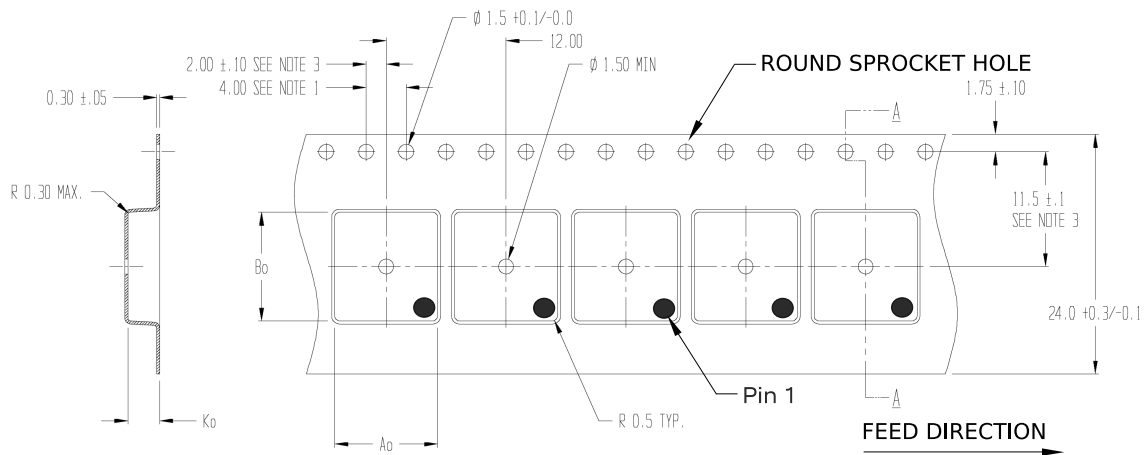

SECTION A - A

$A_0 = 10.30$
 $B_0 = 10.90$
 $K_0 = 3.20$

Measurements in mm.

Tolerances unless noted: 1Pl ± 0.2 2Pl ± 0.10

Notes:

1. 10 sprocket hole pitch cumulative tolerance ± 0.2
2. Pocket position relative to sprocket hole measured as true position of pocket, not pocket hole.
3. A_0 and B_0 are calculated on a plane at a distance "R" above the bottom of the pocket.

Figure 5: Tape specification

8.2 Soldering

Reflow soldering is described in the IPC/JEDEC J-STD-020 standard [5].

9 Product marking and ordering information

This section provides information about product marking and ordering.

9.1 Product marking

The product marking provides information on MAX-M10M-00B and its revision, as in [Figure 6](#). For a description of the product marking, see [Table 23](#)

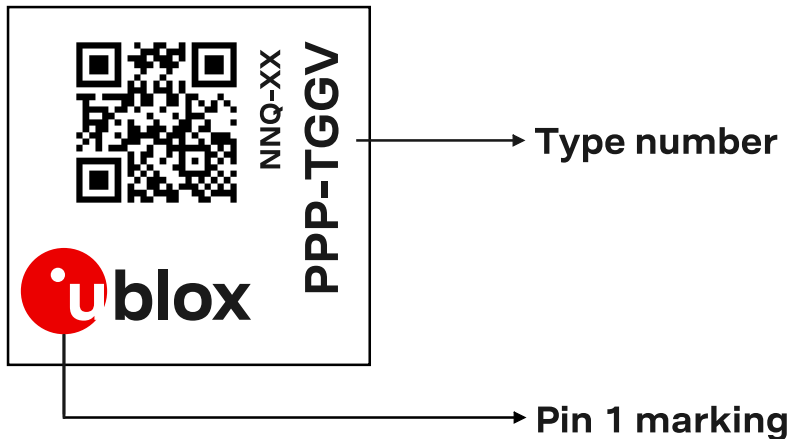

Figure 6: Example of MAX-M10M-00B product marking

Code	Meaning	Example
PPP	Form factor	MAX
TGG	Platform	M10 = u-blox M10
V	Variant	M = Standard precision, ROM and XTAL
NN	Major product version	00, 01, 02, ...
Q	Product grade	A = Automotive, B = Professional
XX	Revision	Hardware and firmware versions

Table 23: Description of product marking

9.2 Product identifiers

The MAX-M10M-00B marking features three product identifiers: product name, ordering code and type number. The product name identifies all u-blox products, independent of packaging and product grade, and it is used in documentation such as this data sheet. The ordering code includes the major product version and product grade, while the type number additionally includes the hardware and firmware versions.

[Table 24](#) describes the three different product identifiers used in the MAX-M10M-00B module product marking.

Identifier	Format	Example
Product name	PPP-TGGV	MAX-M10M
Ordering code	PPP-TGGV-NNQ	MAX-M10M-00B
Type number	PPP-TGGV-NNQ-XX	MAX-M10M-00B-01

Table 24: Product identifiers

9.3 Ordering codes

Ordering code	Product	Remark
MAX-M10M-00B	u-blox M10 GNSS receiver module, professional grade	

Table 25: Product ordering codes

u-blox provides information on product changes affecting the form factor, size or function of the product. For the Product change notifications (PCNs), see our website at: <https://www.u-blox.com/en/product-resources>.

Related documents

- [1] MAX-M10M-00B Integration manual, [UBX-22038241](#)
- [2] u-blox M10 SPG 5.10 Interface description, [UBX-21035062](#)
- [3] u-blox M10 SPG 5.10 Release notes, [UBX-22001426](#)
- [4] Product packaging reference guide, [UBX-14001652](#)
- [5] Joint IPC/JEDEC standard, www.jedec.org



For regular updates to u-blox documentation and to receive product change notifications please register on our homepage <https://www.u-blox.com>.

Revision history

Revision	Date	Status / comments
R01	08-Dec-2022	Advance information.
R02	16-May-2023	Initial production. Changed IN/PCN reference. Updated maximum navigation update rate, sensitivity and BeiDou B1C TTFF in section Performance, ICC_RF in section Absolute maximum ratings, VCC and V_IO supply timing requirements in Operating conditions, and section Mechanical specifications. Added 1 Hz navigation update rate footnote in section Indicative power requirements.
R03	08-Apr-2024	<p>Mass production</p> <p>Added section</p> <ul style="list-style-type: none"> Product handling: Soldering <p>Updated sections</p> <ul style="list-style-type: none"> Supported GNSS constellations: Supported Assisted GNSS (A-GNSS) services Pin assignment Pin state Absolute maximum ratings: V_IO for VIO_SEL = GND Communication interfaces Mechanical specifications: module weight Qualifications and approvals <p>Change in document structure</p> <ul style="list-style-type: none"> Moisture sensitivity level (MSL) included in chapter Qualifications and approvals
R04	16-Jan-2026	<p>Product name changed from MAX-M10M to MAX-M10M-00B in product documentation. There is no change in the product.</p> <p>Added section</p> <ul style="list-style-type: none"> Product handling: Packaging <p>Updated section</p> <ul style="list-style-type: none"> Firmware features: AssistNow service. Legacy AssistNow services Online and Offline are replaced with the corresponding new services Live Orbits and Predictive Orbits.

Contact

u-blox AG

Address: Zürcherstrasse 68
8800 Thalwil
Switzerland

For further support and contact information, visit us at www.u-blox.com/support.