

LEA-M8F

u-blox M8 time & frequency reference GNSS module

Data Sheet



Abstract:

- Concurrent reception of GPS/QZSS, GLONASS, BeiDou
- Integral disciplined low phase-noise 30.72 MHz system reference oscillator
- Accurate measurement and control of external oscillators
- Industry leading acquisition sensitivity and single-satellite timing
- Autonomous 100 ppb hold-over
- Prepared for integration with external PTP, Sync-E and network listen



Document Information

Title	LEA-M8F		
Subtitle	u-blox M8 time & frequency reference GNSS module		
Document type	Data Sheet		
Document number	UBX-14001772		
Revision and date	R07	30 October 2023	
Document status	Production Information		

Document status explanation		
Objective Specification	Document contains target values. Revised and supplementary data will be published later.	
Advance Information	Document contains data based on early testing. Revised and supplementary data will be published later.	
Early Production Information	Document contains data from product verification. Revised and supplementary data may be published later.	
Production Information	Document contains the final product specification.	

This document applies to the following products:

Product name	Type number	ROM/FLASH version	PCN / IN reference
LEA-M8F	LEA-M8F-0-00	ROM2.01 / FLASH FW2.20 FTS1.01	N/A

u-blox or third parties may hold intellectual property rights in the products, names, logos and designs included in this document. Copying, reproduction, modification or disclosure to third parties of this document or any part thereof is only permitted with the express written permission of u-blox.

The information contained herein is provided "as is" and u-blox assumes no liability for its use. No warranty, either express or implied, is given, including but not limited to, with respect to the accuracy, correctness, reliability and fitness for a particular purpose of the information. This document may be revised by u-blox at any time without notice. For the most recent documents, visit www.u-blox.com.

Copyright © u-blox AG.

Contents

Document Information	2
Contents	3
1 Functional description	5
1.1 Overview.....	5
1.2 Product features	5
1.3 GNSS performance.....	6
1.4 Block diagram	7
1.5 GNSS.....	7
1.5.1 GPS	7
1.5.2 GLONASS	7
1.1.1 BeiDou	7
1.5.3 QZSS	7
1.6 AssistNow™ Online (Assisted GNSS, A-GNSS)	8
1.7 Satellite-Based Augmentation System (SBAS)	8
1.8 External frequency and phase inputs (EXTINT)	8
1.9 Protocols and communications interfaces.....	8
1.9.1 Interfaces	9
1.10 Frequency and Time Synchronization (FTS).....	10
1.10.1 Internal oscillator (30.72 MHz VCTCXO)	11
1.10.2 External reference oscillators	11
1.10.3 Host-controlled reference oscillator	11
1.10.4 Frequency or phase inputs	12
1.10.5 External offset measurements.....	12
1.10.6 GNSS receiver with Time Mode	12
1.10.7 Time pulse output.....	13
1.10.8 Time mark	13
1.10.9 Synchronization manager.....	13
1.11 Power management	13
1.12 Antenna.....	13
2 Pin definition	15
3 Configuration management	16
3.1 Interface Selection (D_SEL)	16
4 Electrical specification	17
4.1 Absolute maximum ratings	17
4.2 Operating conditions.....	18
4.3 Indicative current requirements	18
4.4 SPI timing diagrams	19
4.5 DDC timing diagrams	19
5 Mechanical specifications	20
6 Reliability tests and approvals	21
6.1 Reliability tests.....	21
6.2 Approvals.....	21

7	Product handling & soldering	22
7.1	Packaging	22
7.1.1	Reels	22
7.1.2	Tapes	22
7.2	Shipment, storage and handling	23
7.2.1	Moisture Sensitivity Levels	23
7.2.2	Reflow soldering	23
7.2.3	ESD handling precautions	23
8	Default messages	24
9	Labeling and ordering information	25
9.1	Product labeling	25
9.2	Explanation of codes	25
9.3	Ordering codes	25
	Appendix	26
	Related documents	28
	Revision history	29
	Contact	30

1 Functional description

1.1 Overview

u-blox time and frequency products provide multi-GNSS synchronization for cost-sensitive network edge equipment including Small Cell and Femto wireless base-stations. The LEA-M8F module is a fully self-contained phase and frequency reference based on GNSS, but can also be used as part of a complete timing sub-system including macro-sniff Synchronous Ethernet and packet timing. The LEA-M8F module includes a low-noise 30.72 MHz VCTCXO meeting the master reference requirements for LTE Small Cells and provides 100 ppb autonomous hold-over. The LEA-M8F module can also measure and control an external TCXO or OCXO for TD-LTE, LTE-Advanced and other applications requiring extended hold-over. External sources of synchronization are supported through time-pulse and frequency inputs and a message interface. This allows measurements from macro-sniff, Sync-E or packet timing to be combined with measurements from GNSS.

u-blox time and frequency products include timing integrity alarms that report phase and frequency uncertainty both during normal operation and hold-over. They feature a high dynamic range radio with both analog and digital interference mitigation that supports their inclusion as an integral part of a local area base station design. For RF optimization, the LEA-M8F features an additional front-end LNA for easier antenna integration and dual front-end SAW filter for increased jamming immunity.

LEA-M8F module uses GNSS chips qualified according to AEC-Q100. The chips are manufactured in ISO/TS 16949 certified sites and fully tested on a system level. Qualification tests are performed as stipulated in the ISO16750 standard: "Road vehicles – Environmental conditions and testing for electrical and electronic equipment".

u-blox' AssistNow Assistance Service supplies aiding information including ephemeris, almanac, and approximate time. Along with approximate or recent position information supplied locally, these bring significant improvements in both time to first fix and acquisition sensitivity. u-blox M8 AssistNow data supports both GPS and GLONASS constellations.

 See section 1.6 for more information concerning the LEA-M8F receiver related AssistNow Assistance.

1.2 Product features

Model	Type	Supply	Interfaces	Features	Grade
LEA-M8F	GPS/QZSS GLONASS Galileo BeiDou Timing Dead Reckoning Precise Point Positioning Raw Data	3.0 V – 3.6 V Lowest power DC/DC	UART USB SPI DDC (I ² C compliant)	Programmable (flash) Data logging Additional SAW Additional LNA RTC crystal Internal oscillator Active antenna / LNA supply Active antenna / LNA control Antenna short circuit detection / protection pin Antenna open circuit detection pin Frequency output	Standard Professional Automotive
	• • • • •	• •	• D • •	• • • V • P •	•

P = Short circuit protection only

D = Development use

V = VCTCXO

1.3 GNSS performance

Parameter	Specification					
Receiver type	72-channel u-blox M8 engine GPS L1C/A, QZSS L1C/A, SBAS L1C/AGLONASS L1OF BeiDou B1					
GNSS		GPS & GLONASS	GPS & BeiDou	GPS	GLONASS	BeiDou
Time-To-First-Fix ¹	Cold start	26 s	27 s	29 s	30 s	36 s
	Aided cold start ²	2 s	N/A ³	2 s	8 s	N/A ⁴
	Timing fix	15 s additional (all constellations)				
Sensitivity ⁴	Tracking & Navigation	-165 dBm	-165 dBm	-165 dBm	-165 dBm	-160 dBm
	Aided acquisition	-157 dBm	N/A ⁵	-157 dBm	-148 dBm	N/A ⁴
	Reacquisition	-160 dBm	-160 dBm	-160 dBm	-157 dBm	-156 dBm
	Cold start	-148 dBm	-148 dBm	-148 dBm	-145 dBm	-138 dBm
Horizontal position accuracy ⁶	Autonomous	2.5 m	2.5 m	2.5 m	4.0 m	3.0 m
	SBAS	2.0 m	2.0 m	2.0 m	N/A ⁷	N/A ⁸
Velocity accuracy ⁸		0.05 m/s	0.05 m/s	0.05 m/s	0.1 m/s	0.1 m/s
Heading accuracy ⁸		0.3 degrees	0.3 degrees	0.3 degrees	0.4 degrees	N.S ⁹
Max navigation update rate		1 Hz	1 Hz	1 Hz	1 Hz	1 Hz
Time pulse frequency		0.5 Hz...2 Hz				
Time pulse accuracy	Clear sky	≤ 20 ns				
	Indoor	≤ 500 ns				
Frequency accuracy	GNSS locked	≤ 5 ppb				
	Hold-over, 24 hours	≤ 100 ppb max. (< 25 ppb typ. under stable operating conditions)				
Phase noise		-90 dBc/Hz @ 10 Hz				
		-120 dBc/Hz @ 100 Hz				
		-130 dBc/Hz @ 1 kHz				
		-143 dBc/Hz @ 10 kHz				
		-145 dBc/Hz @ 100 kHz				
		-149 dBc/Hz @ 1 MHz				

Table 1: LEA-M8F GNSS performance (Default: GPS, GLONASS and QZSS enabled, SBAS and BeiDou disabled)

¹ All satellites at -130 dBm

² Dependent on aiding data connection speed and latency, time quoted is for fastest constellation

³ BeiDou-assisted acquisitions are not available in this release

⁴ Demonstrated with a good external LNA

⁵ GPS signals are acquired at -157 dBm, BeiDou-assisted acquisitions are not available in this release

⁶ CEP, 50%, 24 hours static, -130 dBm, > 6 SVs

⁷ Not applicable

⁸ 50% @ 30 m/s

⁹ Not specified for this release

1.4 Block diagram

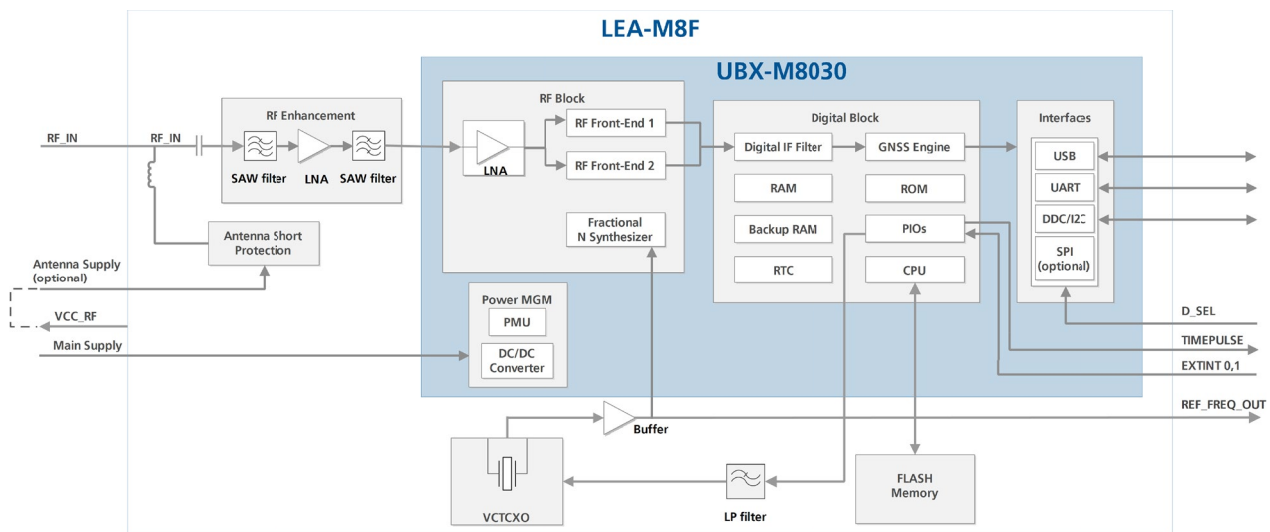

Figure 1: LEA-M8F block diagram

1.5 GNSS

The LEA-M8F is a concurrent GNSS receiver and can receive and track multiple GNSS systems (e.g. GPS/QZSS, GLONASS, and BeiDou signals). Because of the dual-frequency RF front-end architecture, two of the three signals (GPS L1C/A, GLONASS L1OF, and BeiDou B1) can be received and processed concurrently. By default, the LEA-M8F receiver is configured with GPS/QZSS and GLONASS enabled. The LEA-M8F timing and frequency receiver can also be configured to use a single GNSS for the best possible consistency in clear-sky conditions.

- QZSS and SBAS share the same frequency band as GPS and can be processed in conjunction with GPS.

1.5.1 GPS

The LEA-M8F receiver is designed to receive and track the L1C/A signals provided at 1575.42 MHz by the Global Positioning System.

- GPS can be received and processed concurrently with GLONASS or BeiDou.

1.5.2 GLONASS

The LEA-M8F receiver is designed to receive and track the L1OF signals provided at $1602 \text{ MHz} + k \cdot 562.5 \text{ kHz}$ by GLONASS, where k is the satellite's frequency channel number ($k = -7, -6, \dots, 5, 6$).

- GLONASS can be received and processed concurrently with GPS or BeiDou.

1.1.1 BeiDou

The LEA-M8F receiver is designed to receive and track the B1 signals provided at 1561.098 MHz by the BeiDou Navigation Satellite System. The ability to receive and track BeiDou B1 satellite signals in conjunction with GPS results in improved performance within the coverage area.

- BeiDou can be received and processed concurrently with GPS or GLONASS (BeiDou reception is disabled in the default configuration).

1.5.3 QZSS

The Quasi-Zenith Satellite System (QZSS) is a regional navigation satellite system that transmits additional GPS L1C/A signals from high-elevation satellites over the Pacific region between Japan and Australia. LEA-M8F receivers are able to receive and track these signals concurrently with GPS resulting in better availability especially where sky-view is limited e.g. in urban canyons.

 The L1-SAIF signal provided by QZSS is not supported.

1.6 AssistNow™ Online (Assisted GNSS, A-GNSS)

Supply of aiding information, such as ephemeris, almanac, approximate position and time, will reduce the time to first fix and improve the acquisition sensitivity significantly. The LEA-M8F receiver supports the u-blox AssistNow Online Service and is OMA SUPL compliant.

With AssistNow Online, an internet-connected GNSS device downloads assistance data from u-blox' AssistNow Online Service at system start-up. AssistNow Online is network operator independent and globally available. u-blox' servers reduce network bandwidth by sending only useful ephemeris data based on an approximate location supplied during the request. AssistNow Online provides the best time to fix and acquisition sensitivity improvements in continuously-connected applications.

 For more details see the u-blox M8 Receiver Description Including Protocol Specification [\[2\]](#).

1.7 Satellite-Based Augmentation System (SBAS)

The LEA-M8F receiver optionally supports SBAS (including WAAS in the US, EGNOS in Europe, MSAS in Japan and planned networks elsewhere) to deliver improved location accuracy within the regions covered. However, the additional inter-standard time calibration step used during SBAS reception results in degraded time accuracy overall. SBAS is disabled by default in the LEA-M8F.

 SBAS is disabled by default.

1.8 External frequency and phase inputs (EXTINT)

FREQ_PHASE_IN0 (EXINT0) and FREQ_PHASE_IN1 (EXTINT1) are frequency phase inputs provided for connecting an external source of phase (pulse stream) or frequency reference into the LEA-M8F module. These two pins can be configured independently. By default, they provide the facility to mark the time of external events (positive-going edges) in conjunction with the UBXTIM-TM2 message.

 For more information, see the LEA-M8F Hardware Integration Manual [\[1\]](#).

1.9 Protocols and communications interfaces

Protocol	Type
NMEA 0183 V4.0. (V2.3 or V4.1 configurable)	Input/output, ASCII
UBX	Input/output, binary, u-blox proprietary
RTCM 2.3	Input, messages 1, 2, 3, 9

Table 2: Available Protocols

All protocols are available on UART, USB, DDC (I²C compliant) and SPI. For specification of the various protocols, see the u-blox M8 Receiver Description Including Protocol Specification [\[2\]](#).

1.9.1 Interfaces

A number of interfaces are available for data communication, Flash memory access and for an external DAC for controlling an additional oscillator. The firmware uses these interfaces according to their respective protocol specifications.

1.9.1.1 UART

The LEA-M8F receiver makes use of a UART interface that can be used for communication with a host. It supports configurable baud rates. For supported transfer rates, see the u-blox M8 Receiver Description Including Protocol Specification [2].

 Designs must allow access to the UART and a **SAFEBOOT_N** pin for future service, updates and reconfiguration.

1.9.1.2 USB

A USB 2.0 (Full Speed, 12 Mbit/s) compatible interface is available for communication as a development aid. The module is not designed to use the USB interface during operation. For more information, see the LEA-M8F Hardware Integration Manual [1].

u-blox USB (CDC-ACM) driver supports Windows Vista and Windows 7 and Windows 8 operating systems.

 The use of the USB interface is not specified to be compatible with the Top of Second message feature.

1.9.1.3 SPI

The SPI interface is designed to allow communication with a host CPU. The interface can be operated in slave mode only. The maximum sustained transfer rate using SPI is 1 Mbit/s (the interface hardware supports clock rates up to 5.5 MHz).

 SPI is not enabled in the default configuration because its pins are shared with the UART and DDC interfaces. The SPI interface can be enabled by connecting DSEL (pin 5) to ground (details see the LEA-M8F Hardware Integration Manual [1]); in this case the DDC and UART interfaces for data communication are no longer available.

1.9.1.4 Display Data Channel (DDC) Slave

An I²C compliant DDC interface is available for serial communication with an external host CPU. The interface can only be operated in slave mode. The DDC protocol and electrical interface are fully compatible with Fast-Mode of the I²C industry standard. Since the maximum SCL clock frequency is 400 kHz, the maximum transfer rate is 400 kbit/s.

1.9.1.5 Display Data Channel (DDC) Master interface for External DAC Control

A dedicated DDC (I2C) interface (pins SDA_DAC and SCL_DAC) is provided for implementations in which the LEA-M8F controls an external voltage controlled frequency reference via a DAC. This is set up via FTS specific configuration messages. The DDC protocol and electrical interface are compatible with the I²C Fast-Mode industry standard. The interface does not support arbitration or 10-bit addressing, as it is designed as a dedicated DAC control channel and must be the only master on this bus. The SCL clock frequency is designed to run at nominally 400 kHz.

 See the LEA-M8F Hardware Integration Manual [1], the u-blox M8 Receiver Description Protocol Specification [2] and the LEA-M8F System Integration Guide [3] for more information.

1.10 Frequency and Time Synchronization (FTS)

The diagram below summarizes the overall functionality of the LEA-M8F along with the key configuration and reporting messages for each feature. The following sections provide additional detail and important notes for each feature.

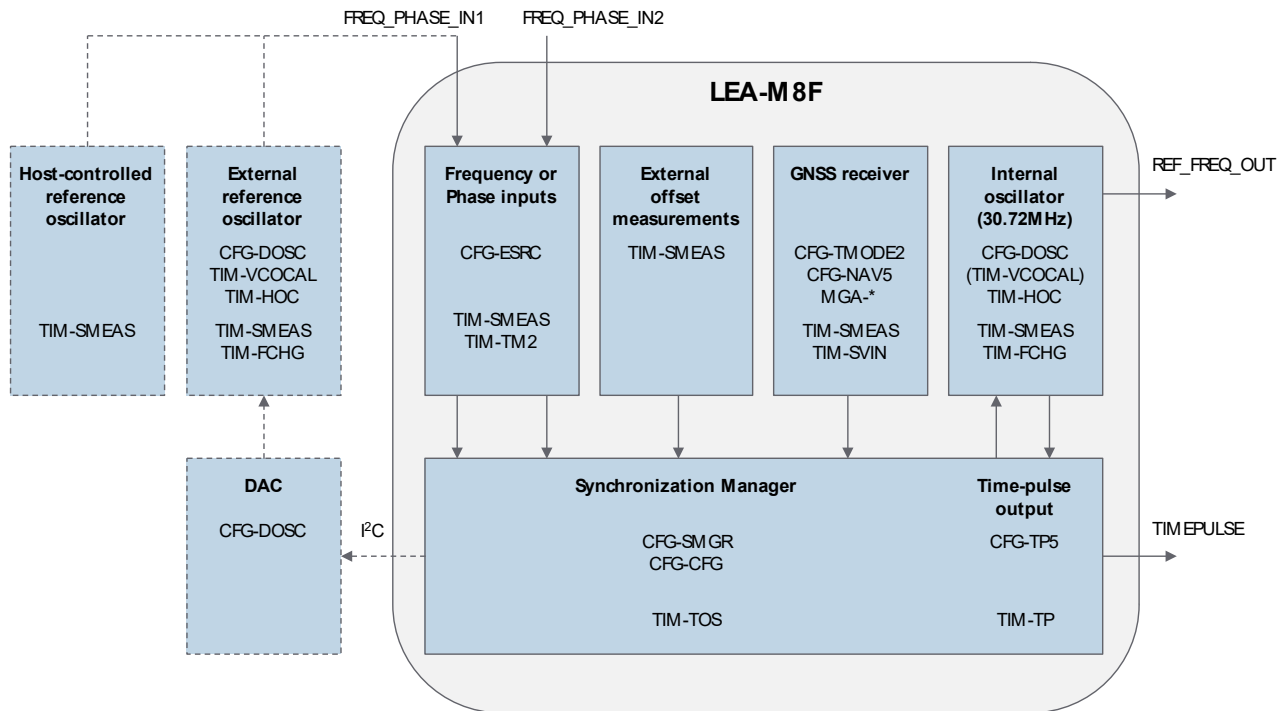

The LEA-M8F offers a self-contained time and frequency reference based on a GNSS receiver and its internal oscillator (an ultra-stable VCTCXO) for hold-over. During normal operation, the frequency of the internal oscillator is corrected continuously (disciplined) to account for changes in temperature. During hold-over the most recent setting is held – the frequency stability is then determined by the oscillator characteristics.

The module accepts external offset measurements in the form of messages from any external system able to independently measure the phase or frequency offset of an oscillator controlled by the module. If these measurements are of better uncertainty than any other measurement or the current uncertainty from hold-over, then the module will use these measurements to control oscillator frequency and time-pulse phase.

The module can also measure frequency and phase offsets based on two frequency or phase inputs (hardware signals) and use these to control oscillator frequency and time-pulse phase. For external measurements and sources, the uncertainties of phase and frequency (and hence whether they are used for control in preference to other sources) are communicated to the module by corresponding messages from the external sub-system.

Optionally the module can control an additional external oscillator by means of an external DAC. This oscillator may be, for example, at a different frequency from the built-in 30.72 MHz VCTCXO or be a VCOCXO offering better hold-over performance. An external oscillator may also be uncontrolled, for example a dedicated OCXO with no DAC, in which case its better stability will be exploited to extend hold-over.

The LEA-M8F can also measure and report the phase and frequency offset of a completely independent oscillator, for example controlled by the host system. The host system can then make any adjustments necessary.

A synchronization manager function coordinates the selection of the best available source of synchronization (based on relative uncertainty), rate limiting of adjustments, and reporting of offsets and uncertainty to the host application.

1.10.1 Internal oscillator (30.72 MHz VCTCXO)

An internal VCTCXO is used to supply the clock frequency for the LEA-M8F's RF and the Baseband PLL. Furthermore, the VCTCXO output is shared via the REF_FREQ_OUT module pin to provide a stable reference frequency for the application. The standard oscillator frequency for LEA-M8F receivers is 30.72 MHz. The VCTCXO provides good phase noise and 100 ppb (24 hour all effects) hold-over performance. Hold-over can also be based on external oscillators of greater stability (OCXO). Stability and tuning slope parameters for this oscillator are set at module manufacture but may be adjusted if necessary with the CFG-DOSC message.

The module includes a utility function for re-calibration of the oscillator slope in the presence of a good source of synchronization (e.g. GNSS) invoked by the TIM-VCOCAL message. Modules are calibrated by u-blox at manufacture and the calibration data can be retained during normal configuration and firmware upgrade processes. The calibration process may be repeated using this message if necessary (e.g. if configuration data are lost or over-written accidentally).

The setting of the internal oscillator control voltage may be overridden if necessary using the TIM-HOC message.



The significant frequency adjustments may impact GNSS performance.

The TIM-SMEAS and TIM-FCHG reporting messages provide respectively information on the current offset of any controlled oscillator and notice of any changes to its frequency control setting.

1.10.2 External reference oscillators

Some applications require a reference of a different frequency or with different stability characteristics than those available from the internal oscillator. In these cases a separate oscillator can be used in conjunction with the LEA-M8F, controlled by the module using an external digital to analog converter connected to the second DDC/I²C (DAC control) interface on pins SDA_DAC and SCL_DAC. The output of the external oscillator (directly or a time-pulse derived from it) is connected to one of the FREQ_PHASE_IN (EXTINT) pins to allow the LEA-M8F module to monitor its frequency and phase offset. Stability and tuning slope parameters for this oscillator are set using the CFG-DOSC message.

The LEA-M8F supports external oscillator frequencies of 10, 13, 19.2, 20, 26, 30.72 and 40 MHz.

The module includes a utility function for calibration of the oscillator slope, invoked by the TIM-VCOCAL message.

The setting of the external oscillator control voltage may be overridden if necessary using the TIM-HOC message.

The TIM-SMEAS and TIM-FCHG reporting messages provide respectively information on the current offset of any controlled oscillator and notice of any changes to its frequency control setting.



For more details, see the u-blox M8 Receiver Description Including Protocol Specification [\[2\]](#) or the LEA-M8F Hardware Integration Manual [\[1\]](#).

1.10.3 Host-controlled reference oscillator

The LEA-M8F can report the phase and frequency of a signal derived from an independent reference oscillator (e.g. a PPS or frame-pulse signal) connected to one of the two FREQ_PHASE_IN pins that may be controlled by the host system. The phase and frequency offsets are reported in the TIM-SMEAS message allowing the host to make any necessary adjustments.

1.10.4 Frequency or phase inputs

Two Frequency or Phase Inputs (FREQ_PHASE_IN0 and FREQ_PHASE_IN1) are available for:

- Applying synchronization signals from external sources,
- The feedback necessary from an external controlled oscillator or
- Marking the time of external events.

The CFG-ESRC message is used to select one of the two synchronization functions for each of these pins independently. Otherwise the time-mark function is enabled by default (reported in TIM-TM2).

The module can make use of external sources of synchronization applied to one or both of the two frequency or phase measurement inputs. The offset and uncertainty of the time-pulses or frequency signals applied to these inputs should be reported to the module using the CFG-ESRC message.

The module can also be configured to expect a stable but unadjusted frequency at one of these inputs (e.g. from an OCXO). In this case the hold-over performance may be improved significantly.

1.10.5 External offset measurements

Where an external system is able to make independent measurements of the phase or frequency offset of either the module's internal oscillator or an external oscillator, the results of these measurements can be provided to the module along with an estimate of the uncertainty of each using the TIM-SMEAS message. The module can then take these measurements into account when determining the best source of synchronization available for oscillator control.

1.10.6 GNSS receiver with Time Mode

The LEA-M8F receiver provides a special Time Mode to support stationary antenna setups, which are typically used in FTS applications. The Time Mode features three different settings enabled by message CFG-TMODE2 and described in Table 3 (Disabled, Survey-In and Fixed Mode). For optimal performance, entering the position of the antenna (when known) is recommended to reduce potential errors.

Time Mode Settings	Description
Disabled	Standard PVT operation
Survey-In	The GNSS receiver computes the average position over an extended time period until a predefined maximum standard deviation has been reached. Afterwards the receiver enters automatically the Fixed Mode. Progress during the survey-in process is reported in the TIM-SVIN message.
Fixed Mode	In this mode, a fixed 3D position and known standard deviation is assumed which helps to stabilize phase control, especially under weak signal conditions. Fixed Mode can either be activated directly by feeding pre-defined position coordinates or by performing Survey-In. In Fixed Mode, the timing errors in the time pulse signal which may result from positioning errors are eliminated. Single satellite operation is supported in Fixed Mode. For details, please refer to the u-blox M8 Receiver Description Including Protocol Specification [2] .

Table 3: Time mode settings

The u-blox M8 multi-GNSS receiver employed in the LEA-M8F can use one of three variants of Universal Coordinated Time (UTC) as the basis for its conversion from native GNSS time to UTC. The selection may be automatic based on signals received or explicitly specified in message CFG-NAV5. This is significant when the time-pulse output has been configured (CFG-TP5) to be aligned with UTC rather than a GNSS time. In this case, a version of UTC should be selected in CFG-NAV5 of which the receiver has knowledge (from aiding messages or from the GNSS signals themselves). Other selections may result in relatively large timing uncertainties until the offset between GNSS time and the selected UTC becomes available (from satellite signals or aiding messages).

1.10.7 Time pulse output

The LEA-M8F module provides a time pulse output, which can be configured from 0.5 Hz up to 2 Hz by message CFG-TP5. The time pulse alignment can be configured to UTC or GNSS time according to the standard used in signals being received or to an alternate standard where inter-standard calibration data is available (from the signals themselves or by aiding). The time pulse is generated with a configurable phase offset and is aligned automatically to the best available source of synchronization which may be the built-in or an external oscillator during hold-over.

After an initial phase of acquisition the time-pulse becomes essentially jitter-free, generated coherently from the built-in reference oscillator and guaranteeing an exact number of reference frequency cycles between each time-pulse.

Step-less phase corrections are made as necessary via small frequency corrections to the reference oscillator. Rates and limits of adjustment for both phase and frequency are controlled by configurable parameters (CFG-SMGR) for both the initial convergence and coherent stages of operation.

 In strong signal clear-sky applications the best time pulse consistency between neighboring receivers is achieved when using a single GNSS because of the small time offsets between different GNSS systems.

1.10.8 Time mark

The LEA-M8F module can also be used for precise time measurements using the external FREQ_PHASE_IN (EXTINT) inputs. Rising edges of these signals are time-stamped with respect to the receiver's active time-base. Time-stamps are reported in the UBX-TIM-TM2 message.

 For more details see the u-blox M8 Receiver Description Including Protocol Specification [\[2\]](#).

1.10.9 Synchronization manager

The synchronization manager selects the best available source of synchronization to use for oscillator control based on the uncertainty information reported by the module's internal GNSS receiver, any external sources and the uncertainty of the most recently used source 'held-over' by the best available oscillator. The synchronization manager controls the time-pulse and any controlled oscillators according to rules and limits configured in message CFG-SMGR. A typical (and default) configuration allows rapid convergence of the time-pulse during initialization and then subsequent adjustment of phase in a fully coherent manner using only small adjustments of frequency.

The synchronization manager provides a consolidated summary report of phase and frequency offset and uncertainty, source selection and integrity and alarm conditions in a TIM-TOS message which is sent in a precisely aligned time window following the corresponding time-pulse. (The TIM-TOS message is sent even if the time-pulse is configured to be inhibited for large uncertainties.)

1.11 Power management

The LEA-M8F receiver offers a power optimized architecture with built-in autonomous power saving functions to minimize overall power consumption. A high efficiency DC-DC converter is integrated to generate the receiver's internal low-voltage supply and make the most efficient use of energy throughout the module's specified supply voltage range.

Adaptive power management ensures that only the necessary sub-systems are active during each phase of operation. Initially the acquisition engine operates at full performance, resulting in the shortest possible TTFF and the highest sensitivity. The acquisition engine searches for all possible satellites until the almanac is completely downloaded. The receiver then switches to an optimized tracking mode to reduce power consumption. During tracking, additional resources are enabled and disabled as necessary to acquire new signals and download ephemeris data.

1.12 Antenna

The LEA-M8F module is designed for using with passive and active ¹⁰ antennas.

Parameter		Specification	
Antenna Type		Passive and active antenna	
Active Recommendations	Antenna	Minimum gain	15 dB (to compensate signal loss in RF cable)
		Maximum gain	30 dB
		Maximum noise figure	1.5 dB

Table 4: Antenna Specifications for LEA-M8F module

¹⁰ For information on using active antennas with LEA-M8F modules, see the LEA-M8F Hardware Integration Manual [\[1\]](#).

2 Pin definition

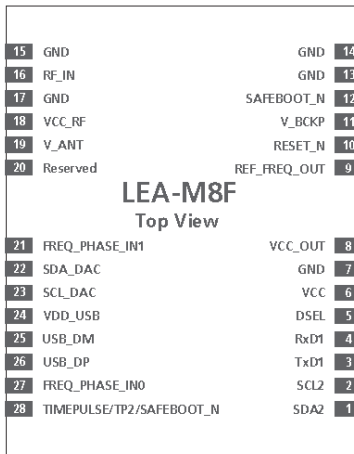

Figure 2: Pin assignment

No	Name	I/O	PIO ¹¹ Nr.	Description
1	SDA2 SPI CS_N	I/O	9	DDC Data if D_SEL = 1 (or open) SPI Chip Select if D_SEL = 0
2	SCL2 SPI CLK	I/O	8	DDC Clock if D_SEL = 1 (or open) SPI Clock if D_SEL = 0
3	TxD1 SPI MISO	O	6	Serial Port if D_SEL = 1 (or open) SPI MISO if D_SEL = 0
4	RxD1 SPI MOSI	I	7	Serial Port if D_SEL = 1 (or open) SPI MOSI if D_SEL = 0
5	DSEL	I	10	Interface Select
6	VCC	I	-	Supply voltage
7	GND	-	-	Ground
8	VCC_OUT	O	-	Output Voltage (VCC)
9	REF_FREQ_OUT	O	-	Disciplined 30.72 MHz signal
10	RESET_N	I	-	RESET_N
11	V_BCKP	I	-	Connect to VCC
12	SAFEBOOT_N	I	-	Test-point for service use (Leave OPEN)
13	GND	-	-	Ground
14	GND	-	-	Ground
15	GND	-	-	Ground
16	RF_IN	I	-	GPS signal input
17	GND	-	-	Ground
18	VCC_RF	O	-	Output Voltage RF section
19	V_ANT	I	-	Active Antenna Voltage Supply
20	Reserved	-	-	Reserved
21	FREQ_PHASE_IN1	I	14	Frequency/phase measurement input
22	SDA_DAC	I/O	15	Additional DDC interface to control and external DAC
23	SCL_DAC	I/O	16	Additional DDC interface to control and external DAC
24	VDD_USB	I	-	USB Supply
25	USB_DM	I/O	-	USB Data
26	USB_DP	I/O	-	USB Data
27	FREQ_PHASE_IN0	I	13	Frequency/phase measurement input
28	TIMEPULSE/TP2/SAFEBOOT_N	I/O	12	SAFEBOOT_N/Timepulse (1 PPS)

Table 5: Pinout

¹¹ Peripheral Input Output

3 Configuration management

Configuration settings can be modified with UBX configuration messages. The modified settings remain effective until power-down or reset. Configuration settings modified with UBX configuration messages can be saved to Flash (using the UBX-CFG-CFG message); in this case, the modified settings will be restored after a power cycle.

The most recently applied DAC settings for both internal and external oscillators are saved automatically to Flash from time to time.

Note that the Time Mode (UBX-CFG-TMODE2) state changes automatically from Survey-in to Fixed Mode when Survey-in completes. The state stored to Flash is the state in use when the UBX-CFG-CFG command is used to save the configuration (which may be Fixed Mode even if Survey-in was originally configured).

3.1 Interface Selection (D_SEL)

At startup, Pin 5 (D_SEL) determines which data interfaces are used for communication. If D_SEL is set high or left open, UART and DDC become available. If D_SEL is set low, i.e. connected to ground, the LEA-M8F module can communicate to a host via SPI.



Pin #	D_SEL="1" (left open)	D_SEL ="0" (connected to GND)
1	DDC SDA	SPI CS_N
2	DDC SCL	SPI CLK
3	UART TX	SPI MISO
4	UART RX	SPI MOSI

Table 6: Data interface selection by D_SEL



For more information, see the LEA-M8F Hardware Integration Manual [\[1\]](#).

4 Electrical specification

-  The limiting values given are in accordance with the Absolute Maximum Rating System (IEC 134). Stress above one or more of the limiting values may cause permanent damage to the device. These are stress ratings only and operation of the device at these or at any other conditions above those given in the characteristics sections of the specification is not implied. Exposure to these limits for extended periods may affect device reliability.
-  Where application information is given, it is advisory only and does not form part of the specification. For more information, see the LEA-M8F Hardware Integration Manual [1].

4.1 Absolute maximum ratings

Parameter	Symbol	Condition	Min	Max	Units
Power supply voltage	VCC		-0.5	3.6	V
USB supply voltage	VDD_USB		-0.5	3.6	V
Input pin voltage	Vin		-0.5	3.6	V
	Vin_usb		-0.5	VDD_USB	V
DC current through any digital I/O pin (except supplies)	Ipin			10	mA
VCC_RF output current	ICC_RF			100	mA
Input power at RF_IN	Prfin	source impedance = 50 Ω, continuous wave		15	dBm
Storage temperature	Tstg		-40	85	°C

Table 7: Absolute maximum ratings

-  Stressing the device beyond the “Absolute Maximum Ratings” may cause permanent damage. These are stress ratings only. The product is not protected against overvoltage or reversed voltages. If necessary, voltage spikes exceeding the power supply voltage specification, given in table above, must be limited to values within the specified boundaries by using appropriate protection diodes.

4.2 Operating conditions

All specifications are at an ambient temperature of +25 °C. Extreme operating temperatures can significantly impact specification values. Applications operating near the temperature limits should be tested to ensure the specification.

Parameter	Symbol	Min	Typical	Max	Units	Condition	
Power supply voltage	VCC	3.0		3.6	V		
Supply voltage USB	VDDUSB	3.0	3.3	3.6	V		
Input pin voltage range	Vin	0		VCC	V		
Digital IO Pin Low level input voltage	Vil	0		0.2*VCC	V		
Digital IO Pin High level input voltage	Vih	0.7*VCC		VCC	V		
Digital IO Pin Low level output voltage	Vol			0.4	V	Iol = 4mA	
Digital IO Pin High level output voltage	Voh	VCC-0.4			V	Ioh = 4mA	
Pull-up resistor for RESET_N	Rpu		11		kΩ		
USB_DM, USB_DP	VinU	Compatible with USB with 27 Ω series resistance					
VCC_RF voltage	VCC_RF		VCC-0.1		V		
VCC_RF output current	ICC_RF			50	mA		
Receiver Chain Noise Figure ¹²	Nftot		2.6		dB		
Operating temperature	Topr	-40		85	°C		

Table 8: Operating conditions

Operation beyond the specified operating conditions can affect device reliability.

4.3 Indicative current requirements

Table 9 lists examples of the total system supply current for a possible application.

The values in [Table 9](#) are provided for customer information only as an example of typical power requirements. Values are characterized on samples, actual power requirements can vary depending on FW version used, external circuitry, number of SVs tracked, signal strength, type of start as well as time, duration and conditions of test.

Parameter	Symbol	Typ GPS & GLONASS	Max	Units	Condition
Max. supply current ¹³	Iccp		67	mA	
Average supply current ¹⁴	Icc ¹⁵	41	44	mA	Estimated at 3.3 V

Table 9: Indicative power requirements at 3.3 V

For more information about power requirements, see the LEA-M8 Hardware Integration Manual [\[1\]](#).

¹² Only valid for the GPS band

¹³ Use this figure to dimension maximum current capability of power supply. Measurement of this parameter with 1 Hz bandwidth.

¹⁴ Simulated GNSS constellation using power levels of -130 dBm. VCC = 3.3 V

¹⁵ Average current from start-up until the first fix.

4.4 SPI timing diagrams

In order to avoid incorrect operation of the SPI, the user needs to comply with certain timing conditions. The following signals need to be considered for timing constraints:

Symbol	Description
SPI CS_N (SS_N)	Slave select signal
SPI CLK (SCK)	Slave clock signal

Table 10: Symbol description

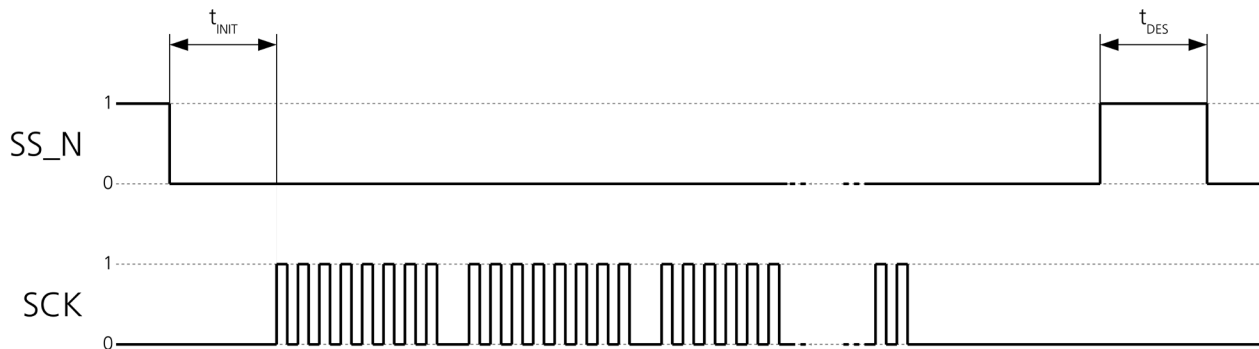

Figure 3: SPI timing diagram

The SPI timing recommendations in Table 11 are based on a firmware running from SQI flash memory.

Parameter	Description	Recommendation
t_{INIT}	Initialization Time	500 μ s
t_{DES}	Deselect Time	1 ms.
Bit rate		1 Mb/s

Table 11: SPI timing recommendations

- The values in the above table result from the requirement of an error-free transmission. By allowing just a few errors and disabling the glitch filter, the bit rate can be increased considerably.

4.5 DDC timing diagrams

The DDC communications interface is I²C Fast Mode compliant. For timing parameters, consult the I²C standard.

- The maximum bit rate is 400 kbit/s. The interface stretches the clock when slowed down while serving interrupts, so real bit rates may be slightly lower.

5 Mechanical specifications

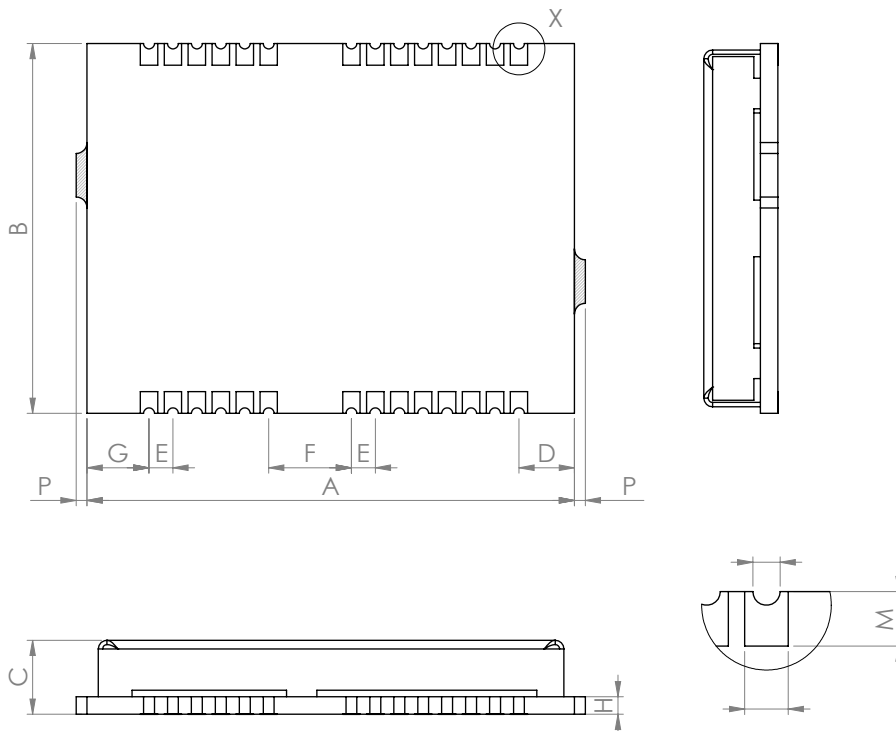



Figure 4: LEA-M8F mechanical drawing

Symbol	Min [mm]	Typ. [mm]	Max [mm]	
A	22.3	22.4	22.5	
B	16.9	17.0	17.1	
C	3.3	3.6	3.9	
D	2.45	2.55	2.65	
E	1.0	1.1	1.2	
F	3.7	3.8	3.9	
G	2.75	2.85	2.95	
H	-	0.82	-	
K	0.7	0.8	0.9	
M	0.9	1.0	1.1	
N	0.4	0.5	0.6	
P*	0.0		0.3	The de-paneling residual tabs are located on both sides of the module
Weight	2.1 g			

Table 12 LEA-M8F mechanical dimensions

-  The mechanical picture of the de-paneling residual tabs (P*) is an approximate representation. The shape and position of the residual tab may vary.
-  When designing the component keep-out area, note that the de-paneling residual tabs are located on both sides of the module.

6 Reliability tests and approvals

6.1 Reliability tests

 LEA-M8F modules are based on AEC-Q100 qualified GNSS chips.

Tests for product family qualifications are according to ISO 16750 “Road vehicles – environmental conditions and testing for electrical and electronic equipment”, and appropriate standards.

6.2 Approvals



Products marked with this lead-free symbol on the product label comply with the “Directive 2002/95/EC of the European Parliament and the Council on the Restriction of Use of certain Hazardous Substances in Electrical and Electronic Equipment” (RoHS).

LEA-M8F is RoHS compliant and green (no halogens).

7 Product handling & soldering

7.1 Packaging

The LEA-M8F GNSS modules are delivered as hermetically sealed, reeled tapes in order to enable efficient production, production lot set-up and tear-down. For more information, see the u-blox Product packaging reference guide [4].

7.1.1 Reels

The LEA-M8F GNSS modules are deliverable in quantities of 250 pieces on a reel. The LEA-M8F receivers are shipped on Reel Type B, as specified in the u-blox Product packaging reference guide [4].

7.1.2 Tapes

The dimensions and orientations of the tapes for LEA-M8F modules are specified in Figure 5.

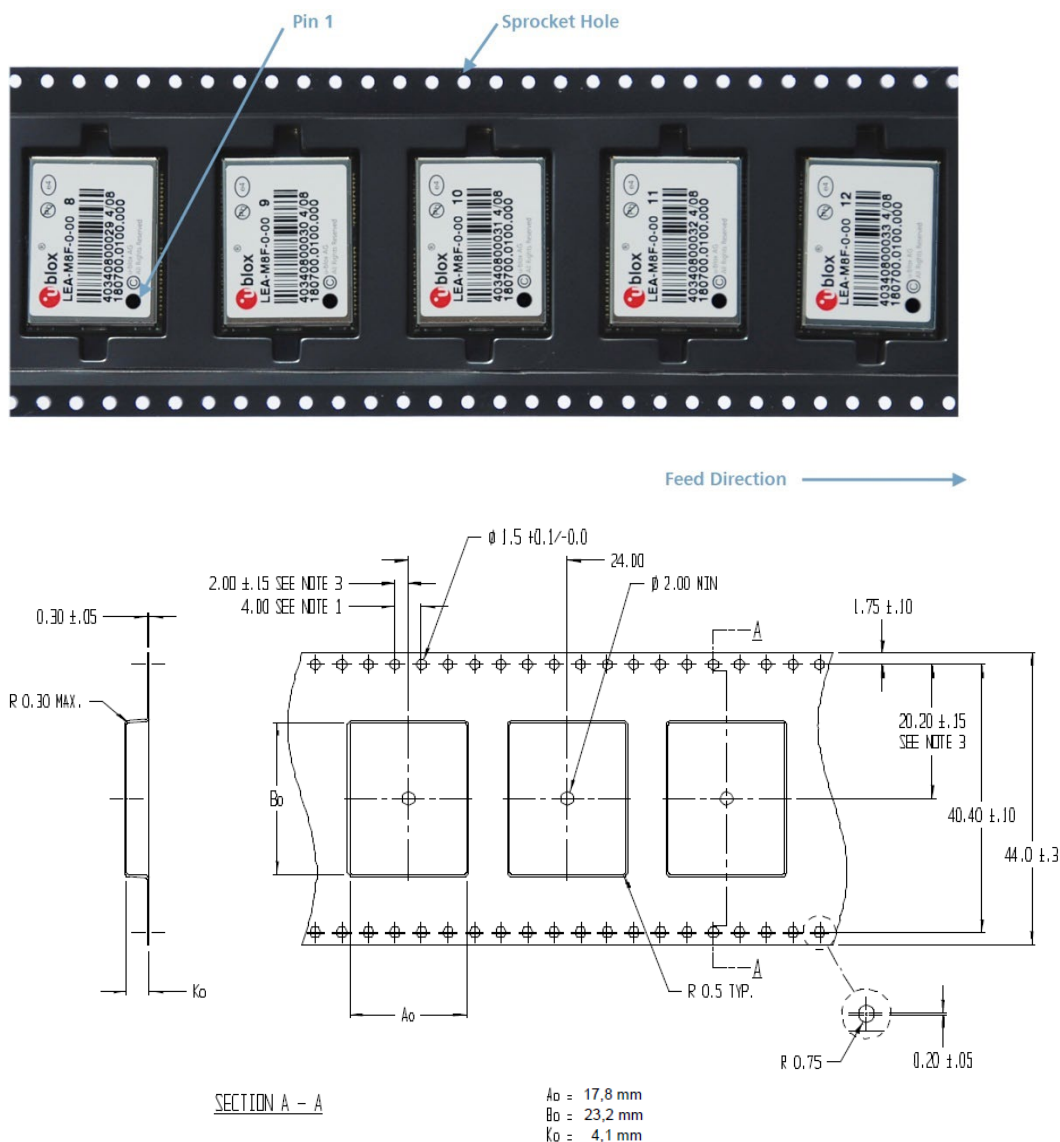



Figure 5: Dimensions and orientation for LEA-M8F modules on tape

7.2 Shipment, storage and handling

For important information regarding shipment, storage and handling, see the u-blox Product packaging reference guide [4].

7.2.1 Moisture Sensitivity Levels

The Moisture Sensitivity Level (MSL) relates to the packaging and handling precautions required. The LEA-M8F modules are rated at MSL level 4.

-  For MSL standard see IPC/JEDEC J-STD-020, which can be downloaded from www.jedec.org.
-  For more information regarding MSL, see the u-blox Product packaging reference guide [4].

7.2.2 Reflow soldering

Reflow profiles are to be selected according u-blox recommendations (see the LEA-M8F Hardware Integration Manual [1]).

7.2.3 ESD handling precautions

-  LEA-M8F modules are Electrostatic Sensitive Devices (ESD). Observe precautions for handling! Failure to observe these precautions can result in severe damage to the GNSS receiver!

GNSS receivers are Electrostatic Sensitive Devices (ESD) and require special precautions when handling. Particular care must be exercised when handling patch antennas, due to the risk of electrostatic charges. In addition to standard ESD safety practices, the following measures should be taken into account whenever handling the receiver:

- Unless there is a galvanic coupling between the local GND (i.e. the work table) and the PCB GND, then the first point of contact when handling the PCB must always be between the local GND and PCB GND.
- Before mounting an antenna patch, connect ground of the device
- When handling the RF pin, do not come into contact with any charged capacitors and be careful when contacting materials that can develop charges (e.g. patch antenna ~10 pF, coax cable ~50-80 pF/m, soldering iron, ...)
- To prevent electrostatic discharge through the RF input, do not touch any exposed antenna area. If there is any risk that such exposed antenna area is touched in non ESD protected work area, implement proper ESD protection measures in the design.
- When soldering RF connectors and patch antennas to the receiver's RF pin, make sure to use an ESD safe soldering iron (tip).

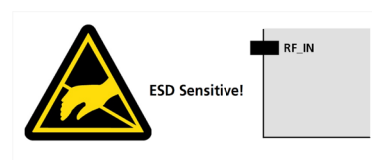

8 Default messages

Interface	Settings
UART Output	9600 Baud, 8 bits, no parity bit, 1 stop bit Configured to transmit both NMEA and UBX protocols, but only the following NMEA (and no UBX) messages have been activated at start-up: GGA, GLL, GSA, GSV, RMC, VTG, TXT (in addition to the 7 standard NMEA messages the LEA-M8F includes ZDA)
USB Output	Configured to transmit both NMEA and UBX protocols, but only the following NMEA (and no UBX) messages have been activated at start-up: GGA, GLL, GSA, GSV, RMC, VTG, TXT USB Power Mode: Bus Powered (in addition to the 7 standard NMEA messages the LEA-M8F includes ZDA)
UART Input	9600 Baud, 8 bits, no parity bit, 1 stop bit, Automatically accepts following protocols without need of explicit configuration: UBX, NMEA The GNSS receiver supports interleaved UBX and NMEA messages.
USB Input	Automatically accepts following protocols without need of explicit configuration: UBX, NMEA The GNSS receiver supports interleaved UBX and NMEA messages. USB Power Mode: Bus Powered
Time pulse	1 pulse per second once time established, synchronized at rising edge, pulse length 100 ms, based on GPS time
Oscillator disciplining	On, disciplined by GNSS alone

Table 13: Default messages (GNSS default: GPS, QZSS and GLONASS enabled, BeiDou and SBAS disabled)

 Refer to the u-blox M8 Receiver Description Including Protocol Specification [2] for information about further settings.

9 Labeling and ordering information

9.1 Product labeling

u-blox M8 GNSS module labels include important product information. The location of the product type number is shown in Figure 6.



Figure 6: Location of product type number on LEA-M8F module label

9.2 Explanation of codes

Three different product code formats are used. The **Product Name** is used in documentation such as this data sheet and identifies all u-blox M8 products, independent of packaging and quality grade. The **Ordering Code** includes options and quality, while the **Type Number** includes the hardware and firmware versions. Table 14 below details these three different formats:

Format	Structure
Product Name	PPP-TGV
Ordering Code	PPP-TGV-T
Type Number	PPP-TGV-T-XX

Table 14: Product Code Formats

The parts of the product code are explained in Table 15.

Code	Meaning	Example
PPP	Product Family	LEA
TG	Product Generation	M8 = u-blox M8
V	Variant	T = Timing, R = DR, etc.
T	Option / Quality Grade	Describes standardized functional element or quality grade such as Flash size, automotive grade etc.
XXX	Product Detail	Describes product details or options such as hard- and software revision, cable length, etc.

Table 15: part identification code

9.3 Ordering codes

Ordering No.	Product
LEA-M8F-0	u-blox M8 timing and frequency reference GNSS module, VCTCXO, Flash, dual SAW, LNA, 17x22.4 mm, 250 pcs/reel

Table 16: Product ordering codes for professional grade module

Product changes affecting form, fit or function are documented by u-blox. For a list of Product Change Notifications (PCNs) see our website.

Appendix

A Glossary

Abbreviation	Definition
ACM	Application Communication Module
ARM	Arm (Advanced RISC Machines) Holdings
AEC	Automotive Electronics Council
BBR	Battery Backed RAM
BER	Bit Error Rate
CPU	Central Processing Unit
CS	Chip Select
CLK	Clock
CDC	Communication Device Class
UTC	Coordinated Universal Time
DCE	Data Communication Equipment
DTE	Data Terminal Equipment
DAC	Digital to Analog Converter
DC	Direct Current
DRX	Discontinuous Reception
DDC	Display Data Channel
DL	Down Link (Reception)
ESD	Electrostatic Sensitive Device
EGNOS	European Geostationary Navigation Overlay Service
FW	Firmware
FTS	Frequency and Time Synchronization
GNSS	Global Navigation Satellite System
GLONASS	GLObal Navigation Satellite System (Russian)
GPS	Global Positioning System
GND	Ground
I/O	Input/Output
I2C	Inter-Integrated Circuit
IEC	International Electrotechnical Commission
ISO	International Organization for Standardization
LTE	Long-Term Evolution
LNA	Low Noise Amplifier
MOSI	Master Output Slave Input
MSL	Moisture Sensitivity Level
MSAS	MTSAT Satellite Augmentation System
MISO	Master Input Slave Output
MOSI	Master Input Slave Output
NMEA	National Marine Electronics Association
N/A	Not Applicable
OEXO	Oven-Controlled Crystal Oscillator / Oven-Compensated Crystal Oscillator
PIO	Peripheral Input/Output
PLL	Phase-Locked Loop
PVT	Position, Velocity, Time

Abbreviation	Definition
PCB	Printed Circuit Board
PCN	Product Change Notification
PPS	Pulse Per Second
QZSS	Quasi-Zenith Satellite System
RF	Radio Frequency
RTCM	Radio Technical Commission for Maritime Services
RAM	Random Access Memory
RTC	Real Time Counter / Real Time Clock
RX	Receive Signal
RMC	Reference Measurement Channel
SBAS	Satellite-Based Augmentation System
SUPL	Secure User Plane Location
SCL	Serial Clock
SDA	Serial Data
SPI	Serial Peripheral Interface
SQI	Serial Quad I/O
SAW	Surface Acoustic Wave
TCXO	Temperature-Compensated Crystal Oscillator
TTFF	Time-To-First-Fix
TX	Transmit Signal
UBX	u-blox proprietary messaging protocol
UART	Universal Asynchronous Receiver/Transmitter
USB	Universal Serial Bus
VCC	Voltage Collector Collector
VCOCXO	Voltage-Controlled Oven-Compensated Crystal Oscillator
VCTCXO	Voltage-Controlled Temperature-Compensated Crystal Oscillator
WAAS	Wide Area Augmentation System

Table 17: Explanation of the abbreviations and terms used

Related documents

- [1] LEA-M8F Hardware Integration Manual, [UBX-14000034](#)
- [2] u-blox M8 Receiver Description Including Protocol Specification (Public version), [UBX-13003221](#)
- [3] LEA-M8F System Integration Guide, [UBX-14001603](#)
- [4] u-blox Product packaging reference guide, [UBX-14001652](#)

 For regular updates to u-blox documentation and to receive product change notifications, register on our homepage <http://www.u-blox.com>.

Revision history

Revision	Date	Status / Comments
R01	24-Apr-2014	Objective Specification
R02	05-Jun-2014	Advance Information; renamed FREQ_PHASE_IN pins from 1, 2 to 0, 1 to match EXTINT pins.
R03	26-Jun-2014	Updated Figure 2 (Pin 11 changed to V_BCKP) and Table 5 Pin 11 name, Pin 21 and Pin 27 description
R04	19-Aug-2014	Early Production Information, added design recommendation in section 1.9.1.1; updated Figure 2 and Table 5 (pin 12 and pin 28).
R05	03-Dec-2014	Updated section 1.2 (added product grade information), updated frequency accuracy in Table 1, updated package information (250 pcs/reel) in section 7.1.1 & 9.3
R06	30-Apr-2015	Production Information
R07	30-Oct-2023	Reformat Chapter Mechanical specifications updated with information on de-paneling residual tabs

Contact

u-blox AG

Address: Zürcherstrasse 68
8800 Thalwil
Switzerland

For further support and contact information, visit us at www.u-blox.com/support.