

ZED-F9K

High precision automotive DR GNSS receiver

Integration manual

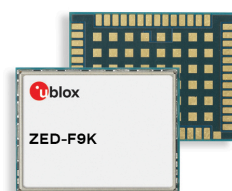

Abstract

This document describes how to enable a successful design with the ZED-F9K module. The ZED-F9K module provides lane-accurate positioning under challenging conditions and decimeter-level accuracy for automotive mass markets. The ZED-F9K module is ideal for ADAS, V2X and head-up displays. It provides a low-risk multi-band RTK turnkey solution with built-in inertial sensors and lag-free displays with up to 50 Hz real-time position update rate.

Document information

Title	ZED-F9K		
Subtitle	High precision automotive DR GNSS receiver		
Document type	Integration manual		
Document number	UBX-20046189		
Revision and date	R04		24-Jul-2023
Disclosure restriction	C1-Public		

This document applies to the following products:

Type number	Firmware version	IN/PCN reference	RN reference
ZED-F9K-00B-00	LAP 1.01	-	UBX-19043673
ZED-F9K-00B-01	LAP 1.20	UBX-20053563	UBX-20045975
ZED-F9K-01A-00	LAP 1.30	-	UBX-22009742

u-blox or third parties may hold intellectual property rights in the products, names, logos and designs included in this document. Copying, reproduction, or modification of this document or any part thereof is only permitted with the express written permission of u-blox. Disclosure to third parties is permitted for clearly public documents only.

The information contained herein is provided "as is" and u-blox assumes no liability for its use. No warranty, either express or implied, is given, including but not limited to, with respect to the accuracy, correctness, reliability and fitness for a particular purpose of the information. This document may be revised by u-blox at any time without notice. For the most recent documents, visit www.u-blox.com.

Copyright © 2023, u-blox AG.

Contents

1 Integration manual overview.....	6
2 System description.....	7
2.1 Overview.....	7
2.1.1 Automotive dead reckoning (ADR).....	7
2.1.2 Priority navigation mode.....	7
2.1.3 Correction services.....	7
2.1.4 Real time kinematic.....	8
2.2 Architecture.....	9
2.2.1 Block diagram.....	9
3 Receiver functionality.....	10
3.1 Receiver configuration.....	10
3.1.1 Changing the receiver configuration.....	10
3.1.2 Default GNSS configuration.....	10
3.1.3 Default interface settings.....	11
3.1.4 Basic receiver configuration.....	11
3.1.5 RTCM corrections.....	13
3.1.6 SPARTN corrections.....	15
3.1.7 Multiple SPARTN sources.....	16
3.1.8 Encrypted SPARTN support.....	17
3.1.9 Navigation configuration.....	18
3.2 Automotive dead reckoning (ADR).....	20
3.2.1 Introduction.....	20
3.2.2 Solution type.....	20
3.2.3 Installation configuration.....	21
3.2.4 Sensor configuration.....	24
3.2.5 ADR system configuration.....	27
3.2.6 Operation.....	28
3.2.7 Priority navigation mode.....	36
3.2.8 Wake on motion feature.....	38
3.3 Primary and secondary output.....	39
3.3.1 Introduction.....	39
3.3.2 Configuration.....	40
3.3.3 Expected output behavior.....	41
3.3.4 Example use cases.....	41
3.4 Protection level.....	42
3.4.1 Introduction.....	42
3.4.2 Interface.....	42
3.4.3 Expected behavior.....	44
3.5 Communication interfaces.....	45
3.5.1 UART.....	46
3.5.2 I2C interface.....	47
3.5.3 SPI interface.....	50
3.5.4 USB interface.....	51
3.5.5 Interface tunneling.....	52

3.6	Predefined PIOs.....	55
3.6.1	D_SEL.....	55
3.6.2	RESET_N.....	55
3.6.3	SAFEBOOT_N.....	55
3.6.4	TIMEPULSE.....	55
3.6.5	TX_READY.....	56
3.6.6	EXTINT.....	56
3.6.7	WT and DIR inputs.....	56
3.6.8	RTK_STAT interface.....	57
3.7	Antenna supervisor.....	57
3.7.1	Antenna voltage control - ANT_OFF.....	58
3.7.2	Antenna short detection - ANT_SHORT_N.....	59
3.7.3	Antenna short detection auto recovery.....	59
3.7.4	Antenna open circuit detection - ANT_DETECT.....	60
3.8	Multiple GNSS assistance (MGA).....	61
3.8.1	Authorization.....	61
3.8.2	Preserving MGA and operational data during power-off.....	61
3.8.3	Save-on-shutdown feature.....	61
3.8.4	Advanced calibration handling.....	62
3.9	Clocks and time.....	64
3.9.1	Receiver local time.....	64
3.9.2	Navigation epochs.....	64
3.9.3	iTOW timestamps.....	65
3.9.4	GNSS times.....	65
3.9.5	Time validity.....	65
3.9.6	UTC representation.....	66
3.9.7	Leap seconds.....	67
3.9.8	Real-time clock.....	67
3.9.9	Date.....	67
3.9.10	Time pulse.....	68
3.9.11	Time mark.....	71
3.10	Security.....	72
3.10.1	Spoofing detection and monitoring.....	73
3.10.2	Jamming interference detection and monitoring.....	73
3.10.3	Spoofing and jamming indication.....	73
3.10.4	GNSS receiver security.....	73
3.11	u-blox protocol feature descriptions.....	74
3.11.1	Broadcast navigation data.....	74
3.12	Forcing a receiver reset.....	83
3.13	Firmware upload.....	83
3.14	Spectrum analyzer.....	84
4	Design.....	86
4.1	Pin assignment.....	86
4.2	Power supply.....	88
4.2.1	VCC: Main supply voltage.....	88
4.2.2	V_BCKP: Backup supply voltage.....	88
4.2.3	ZED-F9K power supply.....	89
4.3	ZED-F9K minimal design.....	89
4.4	WT and DIR interface example.....	90
4.5	Antenna.....	91

4.5.1 Antenna bias.....	93
4.6 EOS/ESD precautions.....	95
4.6.1 ESD protection measures.....	95
4.6.2 EOS precautions.....	96
4.6.3 Safety precautions.....	96
4.7 Electromagnetic interference on I/O lines.....	96
4.7.1 General notes on interference issues.....	97
4.7.2 In-band interference mitigation.....	97
4.7.3 Out-of-band interference.....	98
4.8 Layout.....	98
4.8.1 Placement.....	98
4.8.2 Thermal management.....	98
4.8.3 Package footprint, copper and paste mask.....	99
4.8.4 Layout guidance.....	100
4.9 Design guidance.....	102
4.9.1 General considerations.....	102
4.9.2 Backup battery.....	102
4.9.3 RF front-end circuit options.....	102
4.9.4 Antenna/RF input.....	103
4.9.5 Ground pads.....	104
4.9.6 Schematic design.....	104
4.9.7 Layout design-in guideline.....	104
5 Product handling.....	105
5.1 ESD handling precautions.....	105
5.2 Soldering.....	105
5.3 Tapes.....	109
5.4 Reels.....	110
5.5 Moisture sensitivity levels.....	110
Appendix.....	111
A Glossary.....	111
B Reference frames.....	112
C RTK configuration procedures with u-center.....	112
C.1 Receiver configuration with u-center.....	112
Related documents.....	117
Revision history.....	118

1 Integration manual overview

This document is an important source of information on all aspects of ZED-F9K system, software and hardware design. The purpose of this document is to provide guidelines for a successful integration of the receiver with the customer's end product.

2 System description

2.1 Overview

The ZED-F9K module features the u-blox F9 GNSS platform, which provides continuous decimeter-level positioning accuracy for the most challenging automotive use cases. With LAP 1.30 it supports both L1/L2/E5B and L1/L5 bands for maximum flexibility, satellite availability, and security.

The sophisticated built-in algorithms cleverly fuse the IMU data, GNSS measurements, wheel ticks, and vehicle dynamics model to identify driving lanes where GNSS alone would fail. The module natively supports the u-blox PointPerfect GNSS augmentation service. It delivers multiple GNSS and IMU outputs in parallel to support all possible architectures, including a 50 Hz sensor-fused solution with very low latency. It also enables advanced real-time applications like augmented reality, while the optimized multi-band and multi constellation capability maximizes the number of visible satellites even in urban conditions.

The device is a self-contained solution, which provides the best possible system performance to address issues such as latency constraints, RF front-end design issues, or RTK algorithm integration. This eliminates the technical risk and effort of selecting and integrating RF components and third-party libraries, like positioning engines, which helps customers optimize time to market. The u-blox approach also dramatically reduces supply chain complexity during production.

The u-blox position engine incorporates a dependable protection level output and advanced security features including anti-spoofing and anti-jamming. Operation up to 105 °C makes it possible to integrate the product anywhere in the car without design constraints.

u-blox manufacturing partners use ISO/TS 16949 certified sites and adhere to the latest standards in the automotive industry. Qualification tests are performed as stipulated in the AEC-Q104 standard: "Failure mechanism based stress test qualification for multichip modules (MCM) in automotive applications

2.1.1 Automotive dead reckoning (ADR)

Automotive dead reckoning (ADR) provides high-accuracy positioning in locations with poor or no GNSS coverage. ADR is based on sensor fusion dead reckoning (SFDR) technology, which combines multi-constellation GNSS measurements with the ZED-F9K's internal 6-axis IMU and wheel tick or speed.

See the [ADR](#) section in this document for more information.

2.1.2 Priority navigation mode

Priority navigation mode provides a low-latency position, velocity, and vehicle attitude solution to be output at a high rate by utilizing sensor-based propagation in between GNSS measurement updates, thus prioritizing the time-critical data.

See the [Priority navigation mode](#) section in this document for more information.

2.1.3 Correction services

u-blox ZED-F9K can use different types of correction services which broadly fall into two categories, based either on an Observation Space Representation (OSR) or a State Space Representation (SSR) of the errors. These categories use different techniques, delivery mechanisms, and core

technologies to solve the same problem – the mitigation of key GNSS errors in order to enable high precision GNSS:

1. OSR services provide GNSS observations from the nearest reference station, or virtual reference station (VRS) to the rover. A communication link from reference station or VRS service provider to the rover is needed. The data is dependent on the position of the rover.
2. SSR services rely on GNSS reference station network to model key errors (such as satellite or atmospheric errors) over large geographical regions and provide corrections to the rover via broadcast link such as internet or satellite L-band. All receivers receive the same data over a large area.

In this document, the following terminology is used: RTK refers to OSR-based solution (using RTCM corrections) while PPP-RTK refers to SSR-based solution (using SPARTN corrections). For a complete list of supported SSR protocols please see firmware release notes [3].



PPP-RTK technology is supported from firmware version LAP 1.30 onwards

2.1.4 Real time kinematic

u-blox ZED-F9K high precision receiver takes GNSS precision to the next level:

- Delivers accuracy down to the decimeter level
- Fast time to first fix and robust performance with multi-band, multi-constellation reception
- Compatible with leading correction services for global coverage and versatility

2.2 Architecture

The ZED-F9K receiver provides all the necessary RF and baseband processing to enable multi-band, multi-constellation operation. The block diagram below shows the key functionality.

2.2.1 Block diagram

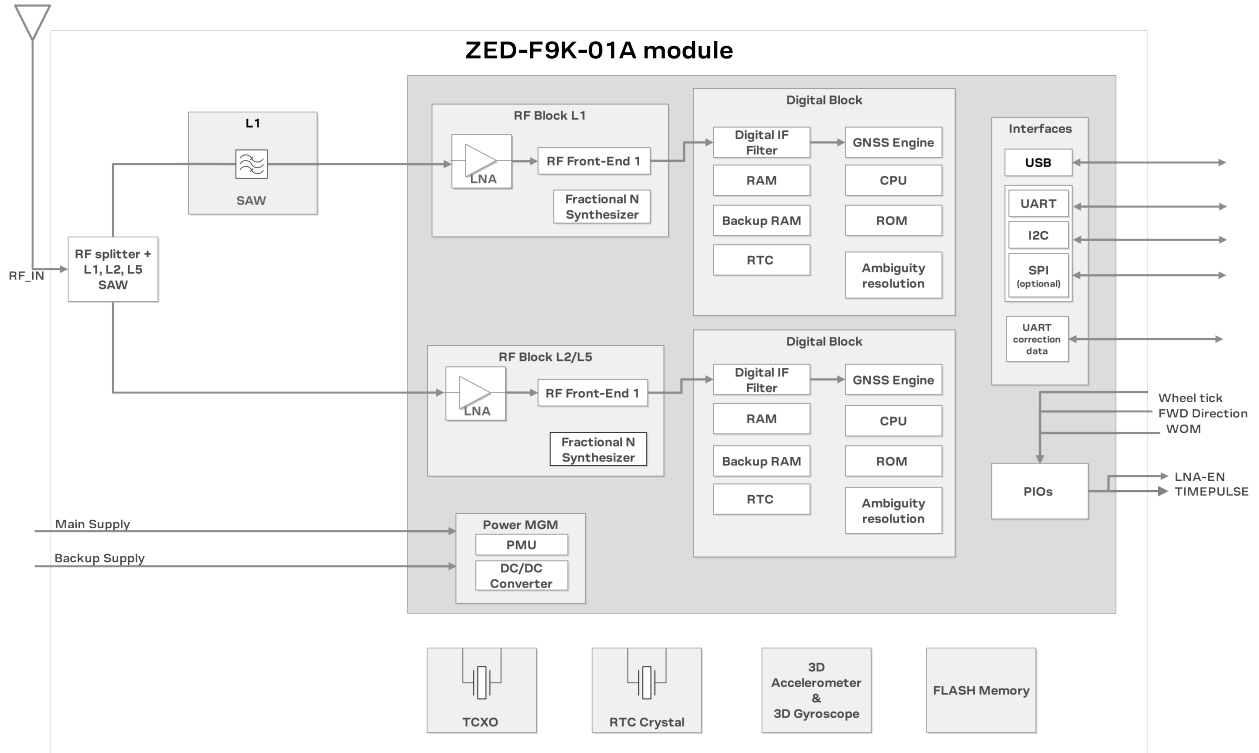

Figure 1: ZED-F9K block diagram

3 Receiver functionality

This section describes the ZED-F9K operational features and their configuration.

3.1 Receiver configuration

ZED-F9K is fully configurable with UBX configuration interface keys. The configuration database in the receiver's RAM holds the current configuration, which is used by the receiver at run-time. It is constructed on startup of the receiver from several sources of configuration. The configuration interface and the available keys are described fully in the applicable interface description [2].

A configuration setting stored in RAM remains effective until power-down or reset. If stored in BBR (battery-backed RAM), the setting will be used as long as the backup battery supply remains. Configuration settings can be saved permanently in flash memory.

 **CAUTION** The configuration interface has changed from earlier u-blox positioning receivers. Legacy messages are deprecated and are not supported LAP 1.30 onwards. Users are advised to adopt the configuration interface described in this document. See legacy UBX-CFG message fields reference section in the applicable interface description [2].

Configuration interface settings are held in a database consisting of separate configuration items. An item is made up of a pair consisting of a key ID and a value. Related items are grouped together and identified under a common group name: CFG-GROUP-*; a convention used in u-center and within this document. Within u-center, a configuration group is identified as "Group name" and the configuration item is identified as the "item name" under the "Generation 9 Configuration View" - "Advanced Configuration" view.

The UBX messages available to change or poll the configurations are UBX-CFG-VALSET, UBX-CFG-VALGET, and UBX-CFG-VALDEL. For more information about these messages and the configuration keys, see the configuration interface section in the applicable interface description [2].

3.1.1 Changing the receiver configuration

The configuration messages UBX-CFG-VALSET, UBX-CFG-VALGET and UBX-CFG-VALDEL will result in a UBX-ACK-ACK or a UBX-ACK-NAK response.

3.1.2 Default GNSS configuration

The ZED-F9K default GNSS configuration is set as follows:

- GPS: L1C/A, L2C
- GLONASS: L1OF, L2OF
- Galileo: E1B/C, E5b
- BeiDou: B1I, B2I
- QZSS: L1C/A, L2C

 With default LAP 1.30 supports L1 L2 configuration, however, the receiver can be configured to L1 L5 combination, by disabling the L2 signals and enabling the L5 signals.

For more information about the default configuration, see the applicable interface description [2].

3.1.3 Default interface settings

Interface	Settings
UART1 output	38400 baud, 8 bits, no parity bit, 1 stop bit. NMEA protocol with GGA, GLL, GSA, GSV, RMC, VTG, TXT messages are output by default. UBX protocol is enabled by default but no output messages are enabled by default. RTCM 3.3 protocol output is not supported.
UART1 input	38400 baud, 8 bits, no parity bit, 1 stop bit. UBX, NMEA and RTCM 3.3 input protocols are enabled by default. SPARTN input protocol is enabled by default.
UART2 output	38400 baud, 8 bits, no parity bit, 1 stop bit. UBX protocol is disabled by default. It can be enabled as an output protocol from firmware version LAP 1.30 onwards. It cannot be enabled as an output protocol on any of the previous firmware versions and will not output UBX messages. RTCM 3.3 protocol output is not supported. NMEA protocol is disabled by default.
UART2 input	38400 baud, 8 bits, no parity bit, 1 stop bit. UBX protocol is disabled by default from firmware version LAP 1.30 onwards. It can be enabled as an input protocol on firmware version LAP1.30. It cannot be enabled as an input protocol on any of the previous firmware versions and will not receive UBX input messages. RTCM 3.3 protocol is enabled by default. SPARTN protocol is enabled by default. NMEA protocol is disabled by default.
USB	Default messages activated as in UART1. Input/output protocols available as in UART1.
I2C	Available for communication in the Fast-mode with an external host CPU in peripheral mode only. Default messages activated as in UART1. Input/output protocols available as in UART1. Maximum bit rate 400 kb/s.
SPI	Allow communication to a host CPU, operated in peripheral mode only. Default messages activated as in UART1. Input/output protocols available as in UART1. SPI is not available unless D_SEL pin is set to low (see the D_SEL section).

Table 1: Default interface settings



By default, the ZED-F9K outputs NMEA messages that include satellite data for all GNSS bands being received. This results in a high NMEA output load for each navigation period. Make sure the UART baud rate used is sufficient for the selected navigation rate and the number of GNSS signals being received.



Do not use UART2 as the only one interface to the host. Not all UBX functionality is available on UART2, such as firmware upgrade, safeboot or backup modes functionalities. No start-up boot screen is sent out from UART2.

3.1.4 Basic receiver configuration

This section summarizes the basic receiver configuration most commonly used.

3.1.4.1 Communication interface configuration

Several configuration groups allow operation mode configuration of the various communication interfaces. These include parameters for the data framing, transfer rate and enabled input/output protocols. See [Communication interfaces](#) section for details. The configuration groups available for each interface are:

Interface	Configuration groups
UART1	CFG-UART1-*, CFG-UART1INPROT-*, CFG-UART1OUTPROT-*
UART2	CFG-UART2-*, CFG-UART2INPROT-*, CFG-UART2OUTPROT-*
USB	CFG-USB-*, CFG-USBINPROT-*, CFG-USBOUTPROT-*
I2C	CFG-I2C-*, CFG-I2CINPROT-*, CFG-I2COUTPROT-*
SPI	CFG-SPI-*, CFG-SPIINPROT-*, CFG-SPIOUTPROT-*

Table 2: Interface configurations

3.1.4.2 Message output configuration

This product supports two protocols for output messages. One is NMEA and the other one is a u-blox proprietary "UBX" protocol. NMEA is a well-known industry standard, used mainly for providing information about position, time and satellites. UBX messages can be used to configure the receiver and also to periodically provide information about position, time and satellites. With the UBX protocol it is easy to monitor the receiver status and get much deeper information about the receiver status. The rate of NMEA and UBX protocol output messages are configurable and it is possible to enable or disable single NMEA or UBX messages individually.

If the rate configuration value is zero, then the corresponding message will not be output. Values greater than zero indicate how often the message is output.

For periodic output messages the rate relates to the event the message is related to. For example, the UBX-NAV-PVT (navigation, position, velocity and time solution) is related to the navigation epoch. If the rate of this message is set to one (1), it will be output for every navigation epoch. If the rate is set to two (2), it will be output every other navigation epoch. The rates of the output messages are individually configurable per communication interface. See the CFG-MSGOUT-* configuration group.

Some messages, such as UBX-MON-VER, are non-periodic and will only be output as an answer to a poll request.

The UBX-INF-* and NMEA-Standard-TXT information messages are non-periodic output messages that do not have a message rate configuration. Instead they can be enabled for each communication interface via the CFG-INFMSG-* configuration group.



All message output is additionally subject to the protocol configuration of the communication interfaces. Messages of a given protocol will not be output until the protocol is enabled for output on the interface (see [Communication interface configuration](#)).

3.1.4.3 GNSS signal configuration

The GNSS constellations and signal bands are selected using keys from configuration group CFG-SIGNAL-*. The ZED-F9K is a multi-band receiver that can optionally select signals in either L1,L2 or L1,L5 GNSS bands. Each GNSS constellation can be enabled or disabled independently except for QZSS and SBAS which are dependant on GPS selection. A GNSS constellation is considered to be enabled when the constellation enable key is set and at least one of the constellation's band keys is enabled.

The following table shows possible configuration key combinations for the GPS constellation.

Constellation key CFG-SIGNAL-GPS_ENA	Band key CFG-SIGNAL-GPS_L1CA_ENA	Band key CFG-SIGNAL-GPS_L2C_ENA	Constellation enabled?
false (0)	false (0)	false (0)	no
false (0)	false (0)	true (1)	no
false (0)	true (1)	false (0)	no

Constellation key CFG-SIGNAL-GPS_ENA	Band key CFG-SIGNAL-GPS_L1CA_ENA	Band key CFG-SIGNAL-GPS_L2C_ENA	Constellation enabled?
false (0)	true (1)	true (1)	no
true (1)	false (0)	false (0)	no
true (1)	false (0)	true (1)	Unsupported combination
true (1)	true (1)	false (0)	yes ¹
true (1)	true (1)	true (1)	yes

Table 3: Example of possible values of configuration items for the GPS constellation

The GPS constellation can be disabled if the SBAS and QZSS system are also disabled at the same time.

3.1.4.4 GNSS switching between L2 and L5 band

Supported with firmware version LAP 1.30

The ZED-F9K supports L1,L2 GNSS band by default. The GNSS bands are selected using keys from configuration group CFG-SIGNAL-*. The ZED-F9K is a multi-band receiver that can optionally select signals in either L1,L2 or L1,L5 GNSS bands. For switching to L1,L5 GNSS band all the L2 band signals should be disabled, only after that the L5 signals should be enabled, and vice versa.

No specific OTP required for switching between L2 and L5 band.

If L1 and L2 band is configured then any signal from L5 band can not be enabled.

After switching the band from L1,L2 to L1,L5 or vice versa, the receiver will output no-fix and will start tracking for satellites.

The following table shows the GNSS signal configuration for L2 and L5 bands.

	GPS	GLONASS	Galileo	BeiDou	Navic
L2	L2C (1227.600 MHz)	L2OF (1246 MHz + k*437.5 kHz, k = -7,...,6)	E5b (1207.140 MHz)	B2I (1207.140 MHz)	-
L5	L5 (1176.450 MHz) -		E5a (1176.450 MHz)	B2a (1176.450 MHz)	-

Table 4: GNSS signal configuration for L2 and L5 bands ZED-F9K

3.1.4.5 NMEA high precision mode

ZED-F9K supports NMEA high precision mode. This mode increases the number of significant digits of the position output; latitude and longitude will have seven digits after the decimal point, and altitude will have three digits after the decimal point. By default it is not enabled since it violates the NMEA standard. NMEA high precision mode cannot be used while in NMEA compatibility mode or when NMEA output is limited to 82 characters. See configuration item CFG-NMEA-HIGHPREC in the applicable interface description [2] for more details.

NMEA high precision mode is disabled by default meaning that the default NMEA output will be insufficient to report a high precision position.

3.1.5 RTCM corrections

RTCM is a standard-based binary protocol for the communication of GNSS correction information. The ZED-F9K high precision receiver supports RTCM as specified by RTCM 10403.3, Differential GNSS (Global Navigation Satellite Systems) Services – Version 3 (October 7, 2016).

¹ The combination works only when GPS L2, GAL E5B, BDS B2, QZSS L2C, and GLO L2 are disabled at the same time.

The RTCM specification is currently at version 3.3 and RTCM version 2 messages are not supported by this standard.

To modify the RTCM input settings, see the configuration section in the applicable interface description [2].

Users need to be aware of the datum used by the correction source. The receiver position will provide coordinates in the correction source reference frame. This may need to be taken into account when using the RTK-derived position. See the [Reference frames](#) section in the Appendix for more information.

3.1.5.1 List of supported RTCM input messages

Message type	Description
RTCM 1001	L1-only GPS RTK observables
RTCM 1002	Extended L1-only GPS RTK observables
RTCM 1003	L1/L2 GPS RTK observables
RTCM 1004	Extended L1/L2 GPS RTK observables
RTCM 1005	Stationary RTK reference station ARP
RTCM 1006	Stationary RTK reference station ARP with antenna height
RTCM 1007	Antenna descriptor
RTCM 1009	L1-only GLONASS RTK observables
RTCM 1010	Extended L1-only GLONASS RTK observables
RTCM 1011	L1/L2 GLONASS RTK observables
RTCM 1012	Extended L1/L2 GLONASS RTK observables
RTCM 1033	Receiver and Antenna Description
RTCM 1074	GPS MSM4
RTCM 1075	GPS MSM5
RTCM 1077	GPS MSM7
RTCM 1084	GLONASS MSM4
RTCM 1085	GLONASS MSM5
RTCM 1087	GLONASS MSM7
RTCM 1094	Galileo MSM4
RTCM 1095	Galileo MSM5
RTCM 1097	Galileo MSM7
RTCM 1124	BeiDou MSM4
RTCM 1125	BeiDou MSM5
RTCM 1127	BeiDou MSM7
RTCM 1230	GLONASS code-phase biases

Table 5: ZED-F9K supported input RTCM version 3.3 messages

3.1.5.2 NTRIP - networked transport of RTCM via internet protocol

Networked Transport of RTCM via internet protocol, or NTRIP, is an open standard protocol for streaming differential data and other kinds of GNSS streaming data over the internet in accordance with specifications published by RTCM.

There are three major parts to the NTRIP system: The NTRIP client, the NTRIP server, and the NTRIP caster:

1. The NTRIP server is a PC or an on-board computer running NTRIP server software communicating directly with a GNSS reference station. The NTRIP server serves as the

intermediary between the GNSS receiver (NTRIP Source) streaming correction data and the NTRIP caster.

2. The NTRIP caster is an HTTP server which receives streaming correction data from one or more NTRIP servers and in turn streams the correction data to one or more NTRIP clients via the internet.
3. The NTRIP client receives streaming correction data from the NTRIP caster to apply as real-time corrections to a GNSS receiver.

[u-center GNSS evaluation software](#) provides an NTRIP client application that can help to evaluate a ZED-F9K design. The u-center NTRIP client connects over the internet to an NTRIP service provider, using access credentials such as user name and password from the service provider. The u-center NTRIP client then forwards the RTCM 3.3 corrections to a ZED-F9K receiver connected to the local u-center application. RTCM corrections from a virtual reference service are also supported by the u-center NTRIP client.

3.1.6 SPARTN corrections

 Supported from firmware version LAP 1.30 onwards

ZED-F9K can receive SPARTN corrections:

- via the internet from a service provider
- via UART, directly connect u-blox NEO-D9S that receives L-band satellite data.

For more information see the [Multiple SPARTN sources](#) section

 PointPerfect services offers SPARTN support

 If you choose PointPerfect service, contact your local u-blox technical support

3.1.6.1 SPARTN protocol

SPARTN is a binary protocol for the communication of SSR correction information.

ZED-F9K supports SPARTN as specified by SPARTN Interface Control Document – Version 2.0.1 (September, 2021).

To modify the SPARTN input/output settings, see the configuration section in the applicable interface description [2].

Users should be aware of the datum used by the correction source.

3.1.6.2 List of supported SPARTN 2.0.1 input messages

Message type-subtype	Description
SM 0-0	GPS orbit, clock, bias (OCB)
SM 0-1	GLONASS orbit, clock, bias (OCB)
SM 0-2	Galileo orbit, clock, bias (OCB)
SM 1-0	GPS high-precision atmosphere correction (HPAC)
SM 1-1	GLONASS high-precision atmosphere correction (HPAC)
SM 1-2	Galileo high-precision atmosphere correction (HPAC)
SM 2-0	Geographic area definition (GAD)

Table 6: ZED-F9K supported input SPARTN version 2.0.1 messages

LAP 1.30 firmware implements SPARTN version 2.0.1 protocol, where:

- Only the messages in [Table 6](#) are supported. The implementation recognizes BeiDou and QZSS messages but is not able to apply these corrections.
- Group and embedded authentication messages are not supported.

- SM1 messages must contain tropospheric model for the receiver to reach an RTK fixed solution.

Application designs using ZED-F9K and SPARTN correction streams should provide firmware upgrade capability; upcoming firmware versions will implement further SPARTN messages and functionalities.

3.1.7 Multiple SPARTN sources

ZED-F9K supports multiple SPARTN correction stream sources. It can support a SPARTN correction stream received over the internet (SPARTN message formatted IP stream) or over L-band satellites (SPARTN L-band stream formatted as UBX-RXM-PMP messages).

Only one source can be configured to be used at a time by ZED-F9K. The configuration item CFG-SPARTN-USE_SOURCE can be configured to select which source will be used. Alternatively, the input protocol configuration items of a physical port can be configured to block input support for the UBX or the SPARTN protocols on the desired ports, for example CFG-UART1INPROT-UBX, CFG-USBINPROT-SPARTN, etc.

Source	Description	CFG-SPARTN-USE_SOURCE
SPARTN IP stream	This refers to corrections received in a SPARTN message format by any interface of the ZED-F9K. The SPARTN corrections must follow the SPARTN protocol specification and the source can be any SPARTN service provider.	IP (default)
SPARTN L-band stream	This refers to corrections received in a UBX-RXM-PMP message format by any interface of the ZED-F9K. UBX-RXM-PMP messages are provided by u-blox L-band NEO-D9S receivers and contain frames of SPARTN messages following the SPARTN protocol specification.	LBAND

Table 7: ZED-F9K supported SPARTN correction stream sources



In case a host application receives a SPARTN L-band stream through other means and converts UBX-RXM-PMP messages to SPARTN messages, then ZED-F9K treats these corrections as a SPARTN IP stream



When providing a SPARTN L-band stream formatted as UBX-RXM-PMP messages, it is recommended to enable both UBX and SPARTN input protocol support on the port where the UBX-RXM-PMP is received. For example, as the default configuration on UART2, where CFG-UART2INPROT-UBX = 1 (true) and CFG-UART2INPROT-SPARTN = 1 (true).

The host application is responsible for deciding which stream to use. This can be based, for example, on the current IP or L-band reception conditions, the needs of the host application, power/cost considerations etc. The ZED-F9K does not provide any intelligent or automatic stream selection.

ZED-F9K provides additional monitoring information in the form of UBX-RXM-COR messages to help identify what is the current stream status in order to assist the host application in deciding which stream to use. UBX-RXM-COR reports, among other information:

- What is the type/subtype of the received SPARTN messages.
- Which is the source of the received SPARTN message (IP or L-band) and if it is used by ZED-F9K.
- What is the signal status in case of L-band streams.

Additionally some SPARTN input status information is also available in other UBX messages, such as UBX-MON-COMMS. For the full message specification, see ZED-F9K Interface description [2].

☞ If the selected SPARTN source contains encrypted SPARTN corrections, then extra monitoring information are reported through UBX-RXM-COR, such as if the message is encrypted and if it got decrypted.

3.1.8 Encrypted SPARTN support

SPARTN messages may be encrypted as indicated by SPARTN field TF004 (Encryption and authentication flag). ZED-F9K supports both encrypted and unencrypted SPARTN messages. Unencrypted SPARTN messages can be utilized as is by ZED-F9K without any special setup. Encrypted SPARTN messages can be decrypted and utilized by ZED-F9K once the appropriate dynamic keys are set and managed by the host application.

☞ The rest of this section describes the steps needed to enable encrypted SPARTN support for the u-blox PointPerfect service only

☞ Different dynamic keys apply for IP-only stream or IP+L-band stream. The type of service available to a user is specified by u-blox Terms and Services.

Step	Description	Example/notes
Obtain PointPerfect dynamic key	Request by any means available a PointPerfect dynamic key lease. It should come in a json structure containing two dynamic keys; the current key and the next key. The request can be postponed if the host application already holds such a json structure obtained earlier and the current time falls within the current key validity time.	current: <ul style="list-style-type: none"> • Key: current key in byte array format • Expires: current key expiring date next: <ul style="list-style-type: none"> • Key: next key in byte array format • Expires: next key expiring date
Check if current and next dynamic keys are currently available	At every power cycle of ZED-F9K or whenever the host application needs to decrypt encrypted SPARTN messages for the first time, poll UBX-RXM-SPARTNKEY to see what are the current and next keys saved in the ZED-F9K. If no key is saved or both keys have expired, then no keys are reported. If one key is available and/or one key has expired, then only one current key is reported. If two keys are available and no key has expired, then both current and next keys are reported.	See description of UBX-RXM-SPARTNKEY message in the applicable interface description [2].
Set current and next dynamic keys	Convert the json structure into a UBX-RXM-SPARTNKEY to set the current and next dynamic keys. This process should be repeated at every power cycle of ZED-F9K, or whenever the host application needs to decrypt encrypted SPARTN messages for the first time, or when the dynamic keys are close to expiring (e.g. only one key is available and is close to expire), or when no dynamic keys are saved.	This will load the current and next dynamic keys in this sequence. See the description of UBX-RXM-SPARTNKEY in the applicable interface description [2]. Although setting the current key only is sufficient, it is recommended that both current and next keys are set.
Forward or relay SPARTN corrections	The host application and design should be such that SPARTN corrections arrive to the ZED-F9K interfaces, either as SPARTN format messages (over an IP stream) and/or as UBX-RXM-PMP format messages (over an L-band stream). In case of multiple SPARTN sources only the one selected by the configuration item CFG-SPARTN-USE_SOURCE will be attempted to be decrypted/used. The other available SPARTN source will not be decrypted and will be reported as such.	
Monitor decryption status	UBX-RXM-COR reports info on the stream selected, if it is encrypted and if the decryption was performed. Further key status information are reported by the UBX-RXM-SPARTNKEY message.	Decryption success cannot be verified in SPARTN messages
Monitor key status	UBX-RXM-SPARTNKEY reports info on the current and next key and if both, or one, or no keys are available.	See description of UBX-RXM-SPARTNKEY message in the applicable interface description [2].

Step	Description	Example/notes
Key switching from current to next	The host application does not need to handle the key switching from current to next, as long as both keys have been saved in the ZED-F9K. Once a current key expires, it gets removed and replaced by the next key (if available). Then only the next key will be available and reported as current. If no next key is available to become current, then the decryption stops and the above steps need to be repeated.	

Table 8: PointPerfect dynamic key handling

3.1.9 Navigation configuration

This section presents various configuration options related to the navigation engine. These options can be configured through CFG-NAVSPG-* configuration keys.

3.1.9.1 Platform settings

u-blox receivers support different dynamic platform models (see the table below) to adjust the navigation engine to the expected application environment. These platform settings can be changed dynamically without performing a power cycle or reset. The settings improve the receiver's interpretation of the measurements and thus provide a more accurate position output. Setting the receiver to an unsuitable platform model for the given application environment is likely to result in a loss of receiver performance and position accuracy.

The dynamic platform model can be configured through the CFG-NAVSPG-DYNMODEL configuration item. The supported dynamic platform models and their details can be seen in [Table 9](#) and [Table 10](#) below.

Platform	Description
Portable	Applications with low acceleration, e.g. portable devices. Suitable for most situations.
Stationary	Used in timing applications (antenna must be stationary) or other stationary applications. Velocity restricted to 0 m/s. Zero dynamics assumed.
Pedestrian	Applications with low acceleration and speed, e.g. how a pedestrian would move. Low acceleration assumed.
Automotive	Used for applications with equivalent dynamics to those of a passenger car. Low vertical acceleration assumed.
At sea	Recommended for applications at sea, with zero vertical velocity. Zero vertical velocity assumed. Sea level assumed.
Airborne <1g	Used for applications with a higher dynamic range and greater vertical acceleration than a passenger car. No 2D position fixes supported.
Airborne <2g	Recommended for typical airborne environments. No 2D position fixes supported.
Airborne <4g	Only recommended for extremely dynamic environments. No 2D position fixes supported.
Wrist	Only recommended for wrist-worn applications. Receiver will filter out arm motion.

Table 9: Dynamic platform models

Platform	Max altitude [m]	Max horizontal velocity [m/s]	Max vertical velocity [m/s]	Sanity check type	Max position deviation
Portable	12000	310	50	Altitude and velocity	Medium
Stationary	9000	10	6	Altitude and velocity	Small
Pedestrian	9000	30	20	Altitude and velocity	Small
Automotive	6000	100	15	Altitude and velocity	Medium
At sea	500	25	5	Altitude and velocity	Medium
Airborne <1g	80000	100	6400	Altitude	Large

Platform	Max altitude [m]	Max horizontal velocity [m/s]	Max vertical velocity [m/s]	Sanity check type	Max position deviation
Airborne <2g	80000	250	10000	Altitude	Large
Airborne <4g	80000	500	20000	Altitude	Large
Wrist	9000	30	20	Altitude and velocity	Medium

Table 10: Dynamic platform model details

ZED-F9K's lane accurate sensor fusion algorithm is optimized for automotive platform only.

Applying dynamic platform models designed for high acceleration systems (e.g. airborne <2g) can result in a higher standard deviation in the reported position.

If a sanity check against a limit of the dynamic platform model fails, then the position solution is invalidated. [Table 10](#) above shows the types of sanity checks which are applied for a particular dynamic platform model.

3.1.9.2 Navigation input filters

The navigation input filters in CFG-NAVSPG-* configuration group provide the input data of the navigation engine.

Configuration item	Description
CFG-NAVSPG-FIXMODE	By default, the receiver calculates a 3D position fix if possible but reverts to 2D position if necessary (auto 2D/3D). The receiver can be forced to only calculate 2D (2D only) or 3D (3D only) positions.
CFG-NAVSPG-CONSTR_ALT, CFG-NAVSPG-CONSTR_ALTVAR	The fixed altitude is used if fixMode is set to 2D only. A variance greater than zero must also be supplied.
CFG-NAVSPG-INFIL_MINELEV	Minimum elevation of a satellite above the horizon in order to be used in the navigation solution. Low elevation satellites may provide degraded accuracy, due to the long signal path through the atmosphere.
CFG-NAVSPG-INFIL_NCNOTHRS, CFG-NAVSPG-INFIL_CNOTHRS	A navigation solution will only be attempted if there are at least the given number of SVs with signals at least as strong as the given threshold.

Table 11: Navigation input filter parameters

If the receiver only has three satellites for calculating a position, the navigation algorithm uses a constant altitude to compensate for the missing fourth satellite. When a satellite is lost after a successful 3D fix (min four satellites available), the altitude is kept constant at the last known value. This is called a 2D fix.

u-blox receivers do not calculate any navigation solution with less than three satellites.

3.1.9.3 Navigation output filters

The result of a navigation solution is initially classified by the fix type (as detailed in the `fixType` field of UBX-NAV-PVT message). This distinguishes between failures to obtain a fix at all ("No Fix") and cases where a fix has been achieved, which are further subdivided into specific types of fixes (e.g. 2D, 3D, dead reckoning).

Where a fix has been achieved, a check is made to determine whether the fix should be classified as valid or not. A fix is only valid if it passes the navigation output filters as defined in CFG-NAVSPG-OUTFIL. In particular, both PDOP and accuracy values must be below the respective limits.

Important: Users are recommended to check the `gnssFixOK` flag in the UBX-NAV-PVT or the NMEA valid flag. Fixes not marked valid should not be used.

UBX-NAV-STATUS message also reports whether a fix is valid in the `gpsFixOK` flag. This message has only been retained for backwards compatibility and users are recommended to use the UBX-NAV-PVT message.



Speed (3D) low-pass filter, course over ground low-pass filter, low-speed course over ground filter, static hold, and freezing the course over ground not supported with the current firmware.

3.1.9.4 Weak signal compensation

In normal operating conditions, low signal strength (i.e. signal attenuation) indicates likely contamination by multi-path. The receiver trusts such signals less in order to preserve the quality of the position solution in poor signal environments. This feature can result in degraded performance in situations where the signals are attenuated for another reason, for example due to antenna placement. In this case, the weak signal compensation feature can be used to restore normal performance. There are three possible modes:

- Disabled: no weak signal compensation is performed
- Automatic: the receiver automatically estimates and compensates for the weak signal
- Configured: the receiver compensates for the weak signal based on a configured value

These modes can be selected using CFG-NAVSPG-SIGATTCOMP. In the case of the "configured" mode, the user should input the maximum C/N0 observed in a clear-sky environment, excluding any outliers or unusually high values. The configured value can have a large impact on the receiver performance, so it should be chosen carefully.

3.2 Automotive dead reckoning (ADR)

3.2.1 Introduction

u-blox solutions for automotive dead reckoning (ADR) allow high-accuracy positioning in places with poor or no GNSS coverage. ADR is based on sensor fusion dead reckoning (SFDR) technology, which combines GNSS measurements with those from external sensors. The ZED-F9K computes a solution type called GAWT (gyroscope, accelerometers, wheel tick) by combining GNSS measurements with the outputs of a 3-axis accelerometer, a 3-axis gyroscope and wheel tick (sometimes called a speed tick) or speed measurements. The utilization of these sensors ensures a quick recovery of the navigation solution after short GNSS signal outage (going under a bridge, signaling panels, and so on).

The firmware automatically detects and continuously calibrates the sensors.

3.2.2 Solution type

ZED-F9K produces a solution that combines GNSS signals with data from gyroscopes, accelerometers and wheel tick sensors to compute a fused navigation solution. The solution type is called GAWT, and it is described in the following sections.

To operate the ZED-F9K in GAWT mode with optimal performance, the following tasks need to be completed:

- The IMU misalignment angles are also essential. It is recommended to enable automatic alignment with the CFG-SFIMU-AUTO_MNTALG_ENA key, if misalignment angles are unknown. The misalignment angles can also be configured manually with CFG-SFIMU-IMU_MNTALG keys. Configuring misalignment angles manually speeds up the calibration procedure.
- It is mandatory to perform an initial calibration drive after flashing software, a cold start, or changing sensor configuration keys (CFG-SFCORE-*, CFG-SFIMU-* or CFG-SFODO-*). The calibration drive allows the software to detect and calibrate the sensors. See section

[Accelerated Initialization and Calibration Procedure](#) for additional information. Performance is likely to be sub-optimal if the calibration drive is not performed correctly.

- If the maximum counter value of a wheel tick sensor cannot be represented as a power of 2 value, it must be configured manually. See section [Odometer Types](#) for additional information.
- It is strongly recommended that RTCM stream is available during the initial calibration drive, so that the resulting calibration parameters can be estimated more accurately.

3.2.3 Installation configuration



If the GNSS antenna is placed at a significant distance from the receiver, position offsets can be introduced which might affect the accuracy of the navigation solution. In order to compensate for the position offset advanced configurations can be applied. Contact u-blox support for more information on advanced configurations.

3.2.3.1 IMU-mount alignment

This section describes how IMU-mount misalignment angles, that is, the angles which rotate the installation frame to the IMU-frame, can be configured.

The IMU-mount misalignment angles are defined as follows:

- The transformation from the installation frame to the IMU frame is described by three Euler angles about the installation frame axes denoted as *IMU-mount roll*, *IMU-mount pitch* and *IMU-mount yaw* angles. All three angles are referred to as the *IMU-mount misalignment angles*.

The default assumption is that the IMU-frame and the installation frame have the same orientation (that is, all axes are parallel). If the IMU-mount misalignment angles are slightly incorrect (typically a few degrees), the navigation solution can be degraded. If there are large (tens of degrees) IMU-mount misalignments, the position calculation may fail. Therefore, it is essential to correctly configure the IMU-mount misalignment settings.



It is strongly recommended to use the automatic IMU-mount alignment as described in the following section.

3.2.3.1.1 Automatic IMU-mount alignment

The automatic IMU-mount alignment engine automatically estimates the IMU-mount roll, pitch and yaw angles. It requires an initialization phase during which no INS/GNSS fusion can be achieved (see the [Fusion filter modes](#) section for further details). The progress of the automatic alignment initialization can be monitored with the UBX-ESF-STATUS message, and/or with the UBX-ESF-ALG message providing more details. When the vehicle is subject to sufficient dynamics (i.e. left and right turns during a normal drive), the automatic IMU-mount alignment engine will estimate the IMU-mount misalignment angles. Once the automatic IMU-mount alignment engine has sufficient confidence in the estimated angles, the IMU-mount misalignment angles initialization phase is completed. The raw accelerometer and gyroscope data (that is, the IMU observations) are then compensated for IMU-mount misalignment and sensor fusion can begin. The resulting IMU-mount misalignment angles are output in the UBX-ESF-ALG message.

Enabling/disabling automatic IMU-mount alignment

The user can activate/deactivate the automatic IMU-mount alignment with the CFG-SFIMU-AUTO_MNTALG_ENA configuration key.



If automatic IMU-mount alignment is deactivated while aligning, the estimated misalignment angles that were available at deactivation time are used (only if they were initialized, see the next section). If automatic IMU-mount alignment is reactivated, alignment is pursued by starting from the state where deactivation happened.

3.2.3.1.2 User-defined IMU-mount alignment

It is possible to configure the IMU-mount misalignment angles using the CFG-SFIMU-IMU_MNTALG configuration keys. The values that should be set in the configuration message are the Euler angles required to rotate the installation frame to the IMU-frame. The IMU-mount yaw rotation should be performed first, then the IMU-mount pitch and finally the IMU-mount roll. At each stage, the rotation is around the appropriate axis of the transformed installation frame, meaning that the order of the rotation sequence is important (see the figure below).

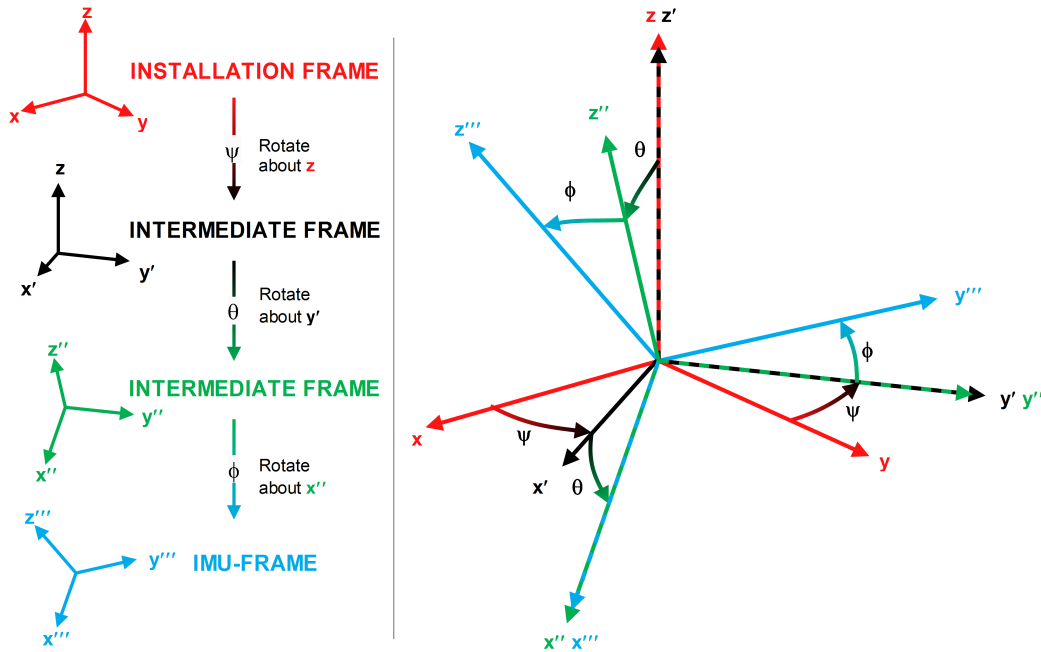

Figure 2: Euler angles

If there is only a single IMU-mount misalignment angle, it may be measured as shown in the three examples below.

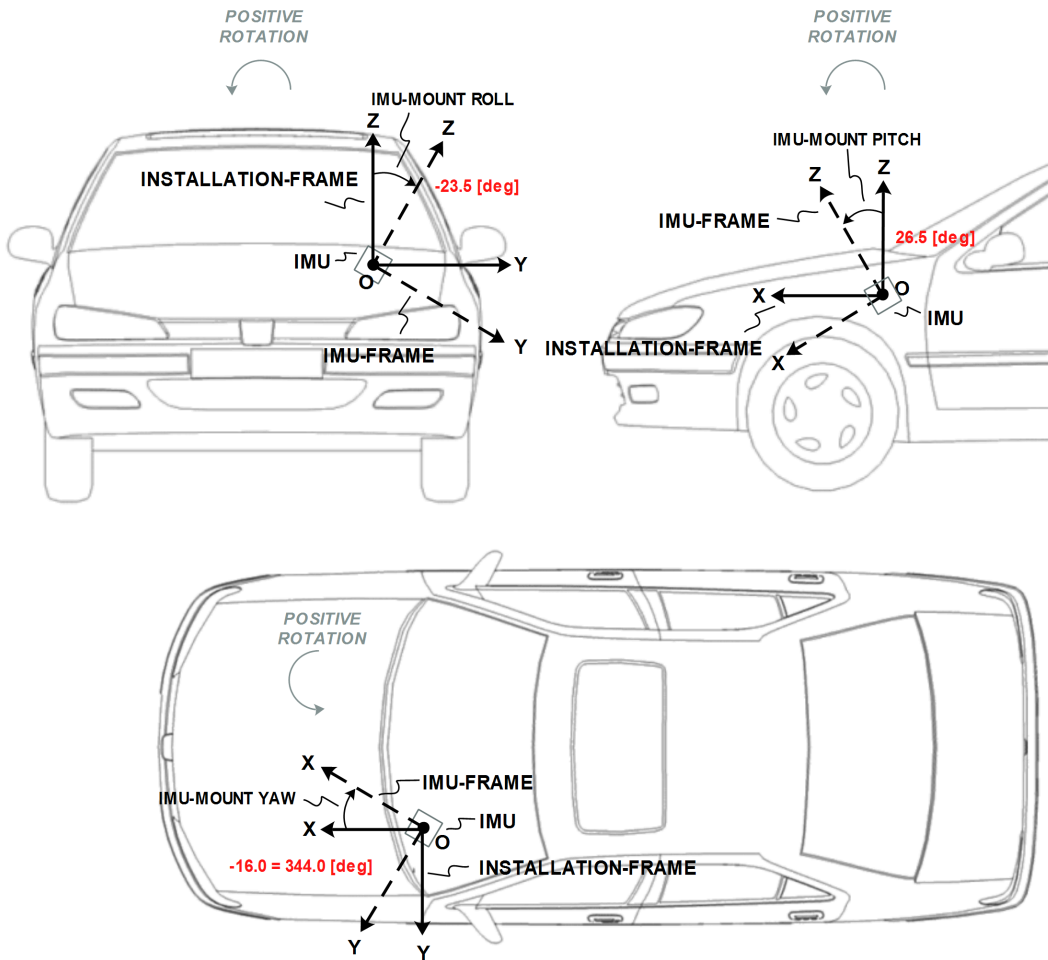

Figure 3: Installation frame



In order to prevent significant degradation of the positioning solution the IMU-mount misalignment angles should be configured with an accuracy of less than 5 degrees.

The following list describes in detail how the CFG-SFIMU-IMU_MNTALG keys are to be interpreted with respect to the example illustrated in the figure above:

- **CFG-SFIMU-IMU_MNTALG_YAW:** The IMU-mount yaw angle (*yaw*) corresponds to the rotation around the installation frame z-axis (vertical) required for aligning the installation frame to the IMU frame (*yaw* = 344.0 degrees if the IMU-mount misalignment is composed of a single rotation around the installation frame z-axis, that is, with no IMU-mount roll and IMU-mount pitch rotation).
- **CFG-SFIMU-IMU_MNTALG_PITCH:** The IMU-mount pitch angle (*pitch*) corresponds to the rotation around the installation frame y-axis required for aligning the installation frame to the IMU-frame (*pitch* = 26.5 degrees if the IMU-mount alignment is composed of a single rotation around the installation frame y-axis, that is, with no IMU-mount roll and IMU-mount yaw rotation).
- **CFG-SFIMU-IMU_MNTALG_ROLL:** The IMU-mount roll angle (*roll*) corresponds to the rotation around the installation frame x-axis required for aligning the installation frame to the IMU frame (*roll* = -23.5 degrees if the IMU-mount misalignment is composed of a single

rotation around installation frame x-axis, that is, with no IMU-mount pitch and IMU-mount yaw rotation).

3.2.4 Sensor configuration

This section describes the external sensor configuration parameters.

3.2.4.1 Odometer configuration

Odometer is a generic term for wheel tick or speed sensor.

You can configure the odometer with the CFG-SFODO-* configuration keys.



The ZED-F9K was designed to work with odometer input. Although the ZED-F9K calculates a position without odometer input (UDR mode), the accuracy of that position is compromised.

3.2.4.1.1 Odometer interfaces

Odometer data can be delivered to ZED-F9K via the following interfaces:

Hardware interface: ZED-F9K has a dedicated pin (WT) for analog wheel tick signal input, and another pin (DIR) dedicated to wheel tick direction signal.

- The WT pin is enabled with the CFG-SFODO-USE_WT_PIN key.
- The DIR pin polarity is automatically detected by the receiver by default. To manually configure the polarity, you must turn off automatic detection by setting the CFG-SFODO-DIS_AUTODIRPINPOL key and you must define the polarity in the CFG-SFODO-DIR_PINPOL key.
- Double-edge counting can be enabled via the CFG-SFODO-CNT_BOTH_EDGES key. It can increase performance with low-resolution wheel ticks, but is not suitable for all types of wheel tick signals. It **must not** be used with signals that are not generated with approximately 50% duty signal as it would impair performance.

Software interface: Odometer data can be delivered to the receiver over one of the communication interfaces. The data shall be contained in UBX-ESF-MEAS messages. UBX-ESF-MEAS (data type 10) shall be used for single-tick odometer data and UBX-ESF-MEAS (data type 11) shall be used for speed odometer data. See the interface description [2] for more information.

- By default, the receiver automatically ignores the WT pin if wheel tick/speed data are detected on the software interface. Therefore data coming from the software interface will be prioritized over data coming from the hardware interface. To disable the automatic use of data detected on the software interface, set the CFG-SFODO-DIS_AUTOSW key.
- While providing the speed data over software interface, the CFG-SFODO-COMBINE_TICKS should remain disabled.

3.2.4.1.2 Odometer types

ZED-F9K supports sensors delivering the following types of data:

- **Relative wheel tick data:** If the wheel tick sensor delivers relative wheel tick counts (that is, wheel tick count since the previous measurement), the CFG-SFODO-COUNT_MAX value must be set to 0.
- **Absolute wheel tick data:** If the wheel tick sensor delivers absolute wheel tick counts (that is, wheel tick count since startup at time tag 0) that always increase, regardless of driving forward or backward (with driving direction indicated separately). If the counter is configured to 1, the maximum absolute wheel tick counter value is automatically estimated by the receiver for a maximum counter value that can be represented as a 2^N value. Other maximum counter values must be manually configured. For example, a CFG-SFODO-COUNT_MAX=1024 roll-over value would be automatically estimated, but a CFG-SFODO-COUNT_MAX=1000 must be configured. The maximum counter value is configured by setting the CFG-SFODO-

DIS_AUTOCOUNTMAX key and setting the CFG-SFODO-COUNT_MAX value to the upper threshold of the absolute wheel tick sensor count before starting again from zero (roll-over).

- **Speed data:** Data coming from this sensor type can only be delivered to the receiver via one of the communication ports within a UBX-ESF-MEAS (data type 11). The speed data shall be delivered in meters per second.

If speed data but no absolute or relative wheel tick data are detected, the receiver automatically uses the speed data without the need for reconfiguring the CFG-SFODO-USE_SPEED key. This behavior can be deactivated by setting the CFG-SFODO-DIS_AUTOSPEED key and by manually setting or clearing the CFG-SFODO-USE_SPEED key. If wheel tick data (or both wheel tick and speed data) are detected on the software interface, the receiver uses the data type (by default wheel tick data) corresponding to the configured CFG-SFODO-USE_SPEED key.

To make the receiver interpret incoming speed data (data type 11 in ESF-MEAS) instead of the single wheel tick data (data type 10 in ESF-MEAS) on the software interface, the CFG-SFODO-USE_SPEED key must be set.



It is strongly recommended to use the absolute wheel tick sensors to ensure robust measurement processing even after sensor failures or outages.

3.2.4.1.3 Odometer settings

You can configure the following odometer settings:

- **Sampling frequency:** The wheel tick/speed data sampling frequency (CFG-SFODO-FREQUENCY) should be provided with an accuracy of approximately 10 %. If not provided, it is automatically determined during the initialization phase: this requires a consistent data rate and can take several minutes. Once initialized, the sampling frequency will be stored in a non-volatile storage. For optimal navigation performance, the standard wheel tick/speed input at 10 Hz is recommended.
- **Latency:** For best positioning performance, the latency of the wheel tick/speed data (CFG-SFODO-LATENCY) should be given as accurately as possible (to within at least 10 ms). If not provided, the wheel tick/speed data latency is assumed zero. More details about latency can be found in the [Sensor Time Tagging](#) section.
- **Quantization error:** If absolute/relative wheel tick data are used (for example, if the tick data is a distance), the quantization error can be defined in the CFG-SFODO-QUANT_ERROR key. The quantization error can be calculated as $2 * \pi * R / T$ with R the wheel radius, T the number of ticks per wheel rotation. If the quantization error is not provided, it is automatically initialized by the receiver.
- **Speed data accuracy (software interface only):** If speed data are used, the speed data accuracy can be set in the CFG-SFODO-QUANT_ERROR key. If not provided, the speed data accuracy is automatically initialized by the receiver.
- **Sensor dead band:** Some wheel tick or speed sensors have a dead band which is the value below which no speed is reported. If this is the case, the value needs to be configured in the CFG-SFODO-SPEED_BAND key. However, the performance will still be degraded compared to having no dead band. If not provided, the receiver assumes the sensor has no dead band.
- **Scale factor:** If the coarse WT scale factor is not configured in the CFG-SFODO-FACTOR key, it is estimated automatically during the initialization (see section [Initialization mode](#) for more details).
- **Combination of multiple rear wheel ticks (software interface only):** If wheel ticks are being received from both rear wheels, the receiver can be configured with the CFG-SFODO-COMBINE_TICKS key to use the combined rear wheel ticks rather than a single tick. It is recommended to use combined rear wheel ticks if available, as they are often of higher quality than the single ticks.

3.2.4.2 UBX-ESF-MEAS time tagging (software interface only)

To achieve optimal performance with the fusion solution it is essential to determine the epoch in the receiver time frame when the UBX-ESF-MEAS sensor data were taken. This may be done in either of the following ways:

- First byte reception: reception time of the first byte of the UBX-ESF-MEAS message
- Time mark on external input: reception time of time mark signal sent to external input

The latency of sensor data is the absolute difference between the time at which the sensor measurement is taken and the time at which either the first byte of the UBX-ESF-MEAS message or the pre-processor's time mark are detected at the receiver.

The latency for the wheel tick can be set with the `CFG-SFODO-LATENCY` key.



It is essential that the time tags used for all UBX-ESF-MEAS data have the same resolution.

ZED-F9K automatically generates UBX-ESF-MEAS messages containing measurements from the internal IMU using the default time tag resolution of 1 millisecond. If the customer wants to input odometer data with UBX-ESF-MEAS messages, it is essential that the odometer time tag has a resolution of 1 millisecond.

3.2.4.2.1 First byte reception

The easiest way to determine the sensor measurement generation time is to have the GNSS receiver assume the time of reception of the first byte of the UBX-ESF-MEAS message (minus the constant configured latency in `CFG-SFODO-LATENCY`) to be the time of sensor measurement. This approach is the simplest to implement, but time mark on external input can yield better latency control and compensation.

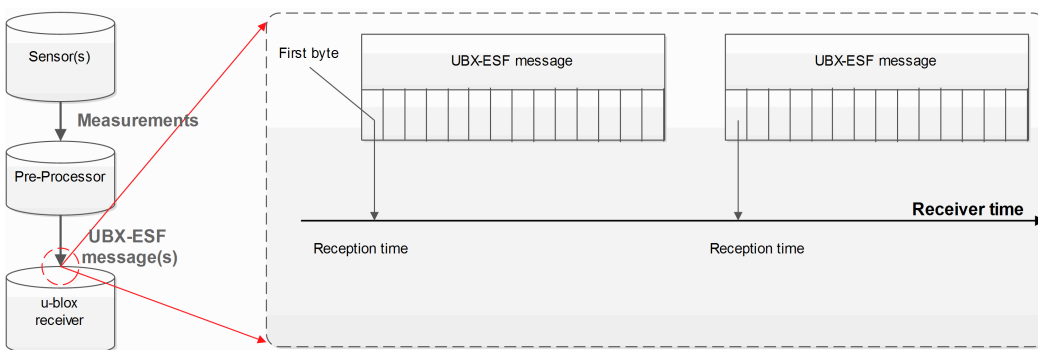

Figure 4: First byte reception

3.2.4.2.2 Time mark on external input

In this case, the preprocessor unit generating the measurements sends a signal to the EXTINT input of the GNSS receiver, marking the moment of the measurement generation. The subsequent UBX-ESF-MEAS message is then flagged accordingly, and the measurements in the message are assumed to have been generated at the time of external signal reception (minus the constant configured latency in `CFG-SFODO-LATENCY`). This approach is the preferred solution, but it can be difficult to realize an exact analog time signal for the preprocessor unit.

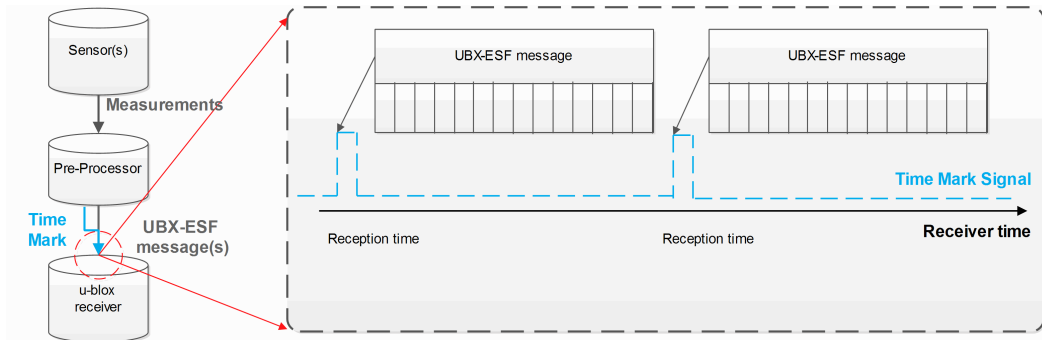

Figure 5: Time mark on external input

3.2.4.2.3 UBX-ESF-MEAS time tagging configuration

The time tag factor can be used to convert the sensor time tags into the required seconds.



It is essential that the time tags used for all UBX-ESF-MEAS data have the same resolution.

ZED-F9K automatically generates UBX-ESF-MEAS messages containing measurements from the internal IMU using the default time tag resolution of 1 millisecond. If the customer wants to input odometer data with UBX-ESF-MEAS messages, it is essential that the odometer time tag has a resolution of 1 millisecond.

ZED-F9K automatically generates UBX-ESF-MEAS messages containing measurements from the internal IMU. If the customer inputs UBX-ESF-MEAS with odometer data with a different sensor time tag factor than the one used by ZED-F9K for IMU data, it will fail!



The same sensor time tag (ttag) factor must be used for all UBX-ESF-MEAS data.

The following sensor time tagging settings need to be specified:

- **CFG-SFCORE-SEN_TTAG_FACT:** This parameter can be used to convert the sensor time tags from their original time unit into the required seconds. It has a resolution of 1 microsecond. The default value is 1000 (1 millisecond).
- **CFG-SFCORE-SEN_TTAG_MAX:** External sensor time tags can be encoded in different data types (signed/unsigned, varying number of bytes) which might vary across sensor types. For example, if the IMU raw packet's time tag field is encoded into an unsigned long integer (4 bytes), the maximum possible time tag value is 4294967295 (0xFFFFFFFF in hexadecimal).

3.2.5 ADR system configuration

3.2.5.1 Enabling/disabling fusion filter

The ADR feature can be enabled and disabled with the `CFG-SFCORE-USE_SF` key. If ADR is disabled, the receiver outputs a GNSS-only solution. IMU sensor measurements are still available in UBX-ESF-MEAS and UBX-ESF-RAW messages.

3.2.5.2 Recommended configuration

In general, it is recommended to use the default configuration values in order to achieve optimal ADR navigation performance.

By default, the navigation solution update rate is 1 Hz. It can be configured with the `CFG-RATE-NAV` key.



At higher navigation rates, it is strongly recommended to check (and maybe reduce) the number of enabled output messages. CPU load, memory and interface bandwidth constraints may be a limiting factor.

3.2.6 Operation

This section describes how the ADR receiver operates.

3.2.6.1 Fusion filter modes

The fusion filter operates in different modes which are output in the UBX-ESF-STATUS message.

The table below summarizes the different fusion filter modes with the receiver's associated tasks.

Mode	Performed tasks / Possible causes	Published fix type
Initialization	Initialization of IMU Initialization of IMU-mount alignment Initialization of INS (position, velocity, attitude) IMU sensor error (e.g. missing data) detected	3D-fix (GNSS)
Fusion	Fine-calibration of IMU-mount misalignment angles Fine-calibration of IMU sensors Fine-calibration of wheel tick factors UDR fallback mode when missing WT data detected	GNSS/DR fix
Suspended fusion	Sensor error (e.g. missing data) detected Ferry detected	3D-fix (GNSS)
Disabled fusion	Fatal fusion filter error occurred Fusion filter turned off by user	3D-fix (GNSS)

Table 12: Fusion modes

More details about each fusion mode are given in the following sections.

3.2.6.1.1 Initialization mode

The purpose of the initialization phase is to estimate all unknown parameters which are required for achieving fusion. The initialization phase is triggered after a receiver cold start or a filter reset in case of fusion failure. The receiver is in initialization mode if the `fusionMode` field in the UBX-ESF-STATUS message is `0:INITIALIZING`. In this case the required sensor calibration status (`calibStatus`) is flagged as `0:NOT CALIBRATED` and the navigation solution output during initialization is based on GNSS solely.

The initialization phase comprises the following internal steps whose status is published in the `initStatus` field of the UBX-ESF-STATUS message:

- IMU initialization:** Unknown crucial IMU parameters such as sensor sampling frequency are estimated during initialization. As long as all required IMU parameters are not initialized, the status of the IMU initialization (`imuInitStatus`) is flagged as `1:INITIALIZING` in the UBX-ESF-STATUS message. Moreover, the required sensor calibration statuses (`calibStatus`) are flagged as `0:NOT CALIBRATED` in the UBX-ESF-STATUS message. Note that if the user configured all required sensor settings, this step is skipped and IMU initialization is flagged as `2:INITIALIZED`.
- IMU-mount alignment initialization:** If automatic IMU-mount alignment is enabled (see the [Automatic IMU-mount alignment](#) section), initial IMU-mount roll, pitch and yaw angles need to be estimated. For that, good GNSS signal reception as well as sufficient vehicle dynamics (i.e. a series of left and right turns during a normal drive) need to be at hand. As long as the IMU-mount alignment is not initialized, the status of the IMU-mount alignment (`mntAlgStatus`)

is flagged as `1:INITIALIZING` in the `UBX-ESF-STATUS` message. Once initialized, the IMU-mount alignment status is flagged as `2:INITIALIZED`. If no IMU-mount alignment is required, the IMU-mount alignment is flagged as `0:OFF`. A detailed description of the automatic IMU-mount alignment operation can be found in the [Automatic IMU-mount alignment](#) section.

- **INS initialization:** Before entering fusion mode, the initial vehicle position, velocity and especially attitude (vehicle roll, pitch and heading angles) need to be known with sufficient accuracy. This is achieved during INS initialization phase using GNSS which comprises an INS coarse alignment step. As long as the fusion filter is not initialized, the status of the INS initialization (`insInitStatus`) is flagged as `1:INITIALIZING` in the `UBX-ESF-STATUS` message. Once initialized, the INS initialization is flagged as `2:INITIALIZED`.
- **Wheel tick sensor initialization:** Solution enters fusion mode (`fusionMode` field in the `UBX-ESF-STATUS` message is on `1:FUSION`), even when wheel tick is not yet initialized, following a UDR mode approach described in [UDR fallback mode](#) section. WT sensor parameters, such as initial wheel tick factor, are estimated in parallel and are used once estimated with sufficient accuracy. As long as the wheel tick parameters are not initialized, the status of the wheel tick initialization (`wtInitStatus`) is flagged as `1:INITIALIZING` in the `UBX-ESF-STATUS` message. Once initialized, the wheel tick sensor initialization is flagged as `2:INITIALIZED`, WT data are used by the filter and the parameters are stored in non-volatile storage. If no wheel tick data are required, the wheel tick initialization is flagged as `0:OFF`.
- **Sensor error (e.g. missing data) detected:** Sensor timeout of more than 500 ms will trigger an INS re-initialization.

Note that initialization phase requires good GNSS signal conditions as well as periods during which vehicle is stationary and moving (including left and right turns). Once all required initialization steps are achieved, fusion mode is triggered and continuous calibration begins.

3.2.6.1.2 Fusion mode

Once initialization phase is achieved, the receiver enters fusion mode. The receiver is in fusion mode if the `UBX-ESF-STATUS.fusionMode` field is set to `1:FUSION`. The fusion filter then starts to compute combined GNSS/dead reckoning fixes (fused solutions) and to calibrate the sensors required for computing the fused navigation solution. This is the case when the sensor calibration status (`UBX-ESF-STATUS.calibStatus`) is set to `1:CALIBRATING`. As soon as the calibration reaches a status where optimal fusion performance can be expected, (`UBX-ESF-STATUS.calibStatus` is set to `2/3:CALIBRATED`).

3.2.6.1.3 UDR fallback mode

In case of WT sensor error / timeout (500 ms), or normal WT sensor initialization, or the WT sensor is not available, the solution falls back to full UDR (untethered dead reckoning) mode. The `UBX-ESF-STATUS.fusionMode` field still shows `1:FUSION` when the receiver enters UDR fallback mode. However, the following flags can be used to determine when the receiver has entered UDR mode:

- The `UBX-ESF-STATUS.wtInitStatus` shows `1:INITIALIZING`.
- The WT fault flag, `UBX-ESF-STATUS.missingMeas` field, is set to `1`, indicating a WT timeout has been detected.

In the UDR fallback mode, the receiver does not lock the position while the vehicle is stationary, so the position could drift slightly, based on the GNSS conditions. The receiver needs WT for stationary phase detection.

3.2.6.1.4 Directionless odometer mode

This feature allows the use of odometer data for which the sign bit or the wheel tick (WT) pin polarity input is not trusted or not available. The directionless odometer support can be enabled by the configuration item `CFG-SFODO-DIS_DIR_INFO=1`.

After setting this configuration item, the directional information, that is, the polarity bit of the WT measurement and the sign of the wheel speed measurement in the `UBX-ESF-MEAS` message as well as the WT polarity pin input will be ignored. In particular, the following configuration items shall have no effect when used in combination with `CFG-SFODO-DIS_DIR_INFO=1`.

- `CFG-SFODO-DIR_PINPOL`
- `CFG-SFODO-DIS_AUTODIRPINPOL`

The performance with directionless odometer feature is expected to be worse than that of ADR with usual directional odometer data, but better than that of the UDR fallback mode.



The odometer measurements shall be used as a velocity measurement only if the direction of motion (forwards/backwards) can be reliably determined based on other measurements (GNSS, IMU). Typically, this requires high enough speed.

3.2.6.1.5 Suspended fusion mode

Sensor fusion is temporarily suspended in cases where no fused solution should/can be computed. In this case, the receiver produces a GNSS-only solution. The receiver is considered to be in temporarily disabled fusion mode when the `UBX-ESF-STATUS.fusionMode` field is set to `2:SUSPENDED`.

Fusion is suspended in the following scenarios:

- If one or several sensors deliver erroneous data or no data at all. Fusion is suspended during the sensor failure period. The receiver automatically recovers once the affected sensor or sensors are back to normal operation.
- If the vehicle is detected to be on a ferry or other moving platform, where odometer data does not indicate any displacement.

3.2.6.1.6 Disabled fusion mode

Sensor fusion can be permanently disabled if recurrent fusion failures occur. The receiver is considered to be in permanently disabled fusion mode if the `UBX-ESF-STATUS.fusionMode` field is set to `3:DISABLED`. In this case, the receiver produces a GNSS-only solution if possible.

Fusion is permanently disabled in the following cases:

- If the fusion filter was manually turned off by the user with the `CFG-SFCORE-USE_SF` key.
- If the filter diverges due to significantly wrong installation or filter parameters.

3.2.6.2 Accelerated initialization and calibration procedure

This section describes how to perform fast initialization and calibration of the ADR receiver for evaluation purposes.

The duration of the initialization phases depends on the quality of the GNSS signals and the dynamics encountered by the vehicle.

You can shorten the initialization time required to reach sensor fusion mode by following the procedure in the order described in the table below.

Phase	Procedure	Indicator of success
IMU initialization	After receiver cold start or first receiver use, turn on car engine and stay stationary under good GNSS signal reception conditions for at least 3 minutes.	IMU initialization status <code>UBX-ESF-STATUS.imuInitStatus</code> shows <code>2:INITIALIZED</code> .
INS initialization (position and velocity)	Once IMU is initialized, stay stationary under good GNSS signal reception conditions until a reliable GNSS fix can be achieved.	GNSS 3D fix achieved, good 3D position accuracy (at least 5 m), high number of used satellites (check <code>UBX-NAV-PVT</code> message).

Phase	Procedure	Indicator of success
IMU-mount alignment initialization	Start driving at a minimum speed of 30 km/h and do a series of approximately 10 left and right turns (at least 90 degrees).	IMU-mount alignment status (UBX-ESF-STATUS.mntAlgStatus) shows 2:INITIALIZED, the IMU-mount alignment status UBX-ESF-ALG.status shows 3:COARSE ALIGNED.
Wheel tick sensor initialization	Drive for at least 500 meters at a minimum speed of 30 km/h. To shorten this calibration step, drive the car at a higher speed (around 50 km/h) for at least 10 seconds under good GNSS visibility. <i>You can skip this step if automatic wheel tick pin polarity detection is turned off.</i>	Wheel tick sensor initialization status UBX-ESF-STATUS.wtInitStatus shows 2:INITIALIZED.
INS initialization (attitude)	Drive straight for at least 100 meters at a minimum speed of 40 km/h. <i>The system will start initializing at 18 km/h and can achieve specified accuracy at 40 km/h.</i>	INS initialization status UBX-ESF-STATUS.insInitStatus shows 2:INITIALIZED.

Table 13: Accelerated initialization procedure

Once initialization is completed, the UBX-ESF-STATUS.fusionMode field shows 1:FUSION, combined GNSS/dead reckoning fixes (fused solutions) are output and the sensors used in the navigation filter start calibrating. Calibration is a continuous process running in the background, and it directly impacts the navigation solution quality.

You can shorten the calibration time required for reaching optimal ADR navigation performance by following the procedure described in the table below.

Phase	Procedure	Indicator of success
IMU-mount alignment calibration	Keep driving at a minimum speed of 30 km/h and do a series of left and right turns (at least 90 degrees). At each turn the estimated IMU-mount misalignment angles are refined and their accuracy increased.	Once the IMU-mount alignment engine has high confidence in its misalignment angle estimates, the IMU-mount alignment status UBX-ESF-ALG.status is set to 4:FINE ALIGNED.
IMU calibration (gyroscope and accelerometer)	Drive curves and straight segments for a few minutes by including a few stops lasting at least 30 seconds each. This drive should also include some periods with higher speed (at least 50 km/h) and can typically be carried out on normal open-sky roads with good GNSS signal reception conditions.	The calibration status of the used sensors UBX-ESF-STATUS.calibStatus shows 2/3:CALIBRATED.

Table 14: Accelerated calibration procedure

Note that the calibration status (UBX-ESF-STATUS.calibStatus) of some used sensors might fall back to 1:CALIBRATING if the receiver is operated in challenging conditions. In such a case, fused navigation solution uncertainty increases until optimal conditions are observed again for recalibrating the sensors.



In the presence of significant temperature gradient affecting the gyroscopes, the fused navigation performance might also depend on how well the temperature compensation table is populated. The table is gradually filled in while the vehicle is stationary and by observing gyroscope biases at different temperatures. Therefore the quality of the gyroscope temperature compensation depends on how many temperature bins could be observed while the vehicle was stationary and on the duration of the observation for each bin.

3.2.6.3 Automatic IMU-mount alignment

3.2.6.3.1 Alignment solution output

The IMU-mount misalignment angles are shown in UBX-ESF-ALG messages.

- **IMU-mount angle initialization:** During IMU-mount angle initialization the (`UBX-ESF-ALG.status` field is equal to 2), and the published angles (`yaw`, `pitch` and `roll`) correspond to the current estimated values but are not yet applied for rotating the IMU observations.
- **IMU-mount angle initialization complete:** After initialization the (`UBX-ESF-ALG.status` field is equal to or higher than 3), the published angles correspond to the estimated value and are applied for rotating the IMU observations.
- **Automatic IMU-mount alignment disabled:** If automatic IMU-mount alignment is disabled, the published angles correspond to the IMU-mount angles configured by the the user (see [User-defined IMU-mount Alignment](#) section) and are applied for rotating the IMU observations.

 **CAUTION** If user-defined IMU-mount misalignment angles were configured by the user using `CFG-SFIMU-IMU_MNTALG` keys (see [User-defined IMU-mount alignment](#) section) and automatic IMU-mount alignment is active, the angles output in the `UBX-ESF-ALG` message still correspond to the definition given above: they represent the full rotation required for transforming IMU data from installation frame to IMU frame. This means that the output misalignment angles are computed from the composed rotation of the user-defined rotation and the internally-estimated rotation.

3.2.6.3.2 Alignment progress

The progress of the automatic IMU-mount alignment can be monitored by checking the `UBX-ESF-ALG.status` field.

- **IMU-mount roll/pitch angle initialization ongoing:** The alignment engine is initializing the IMU-mount roll and pitch angles (`UBX-ESF-ALG.status` is 1). Both angles can only be initialized if vehicle encounters left and right turns (as during a normal drive).
- **IMU-mount yaw angle initialization ongoing:** The alignment engine is initializing the IMU-mount yaw angle (`UBX-ESF-ALG.status` is 2). IMU-mount yaw angle can only be initialized once IMU-mount roll and pitch angles are initialized and if vehicle encounters left and right turns (as during a normal drive).
- **IMU-mount alignment coarse calibration ongoing:** Once initialized (`UBX-ESF-ALG.status` is 3), the automatic IMU-mount alignment engine has sufficient confidence in all IMU-mount misalignment angles and validates their use for compensating the accelerometer and gyroscope data (fused navigation solutions can be computed). The IMU-mount misalignment angles are filtered each time the observed vehicle dynamics are measurable.
- **IMU-mount alignment fine calibration ongoing:** Once the IMU-mount misalignment angles are estimated with a good accuracy, the automatic IMU-mount alignment engine becomes more conservative in updating the IMU-mount misalignment angles (`UBX-ESF-ALG.status` is 4).

3.2.6.3.3 Alignment reset

If for some reasons the IMU-mount misalignment angles estimated by the automatic IMU-mount alignment engine are no longer valid (for example due to a change in the physical mounting of the device), the IMU-mount misalignment angles can be reset by sending a `UBX-ESF-RESETALG` message. In addition, the misalignment angles are also reset in the following cases:

- If a cold start command is sent.
- If the user-defined IMU-mount misalignment angles are changed by sending `CFG-SFIMU-IMU_MNTALG` keys (see [User-defined IMU-mount alignment](#) section for more details).

The IMU-mount alignment engine then falls back into initialization mode.

3.2.6.3.4 Alignment errors

The following errors might be output in the `UBX-ESF-ALG.error` bit field:

- **IMU-mount roll/pitch angle error:** If the automatic IMU-mount alignment engine suspects wrong IMU-mount roll and/or IMU-mount pitch misalignment angles (either due to a wrong

initialization or a change in the physical mounting of the device), the `UBX-ESF-ALG.error` bit 0 is set to 1.

- **IMU-mount yaw angle error:** If the automatic IMU-mount alignment engine suspects wrong IMU-mount yaw misalignment angle (either due to a wrong initialization or a change in the physical mounting of the device), the `UBX-ESF-ALG.error` bit 1 is set to 1.
- **Euler angle singularity ('gimbal-lock') error:** The Euler angle singularity `UBX-ESF-ALG.error` bit 2 is set when the automatic IMU-mount alignment engine detects an installation where the IMU frame is misaligned in such a way that a degree of freedom is lost when two IMU-mount misalignment (Euler) angles begin to describe the same rotations (or axes). This happens, for example, with an IMU-mount misalignment of +/- 90 degrees around the IMU-mount pitch axis, where IMU-mount roll and IMU-mount yaw cannot be distinguished from each other. In such a case, these IMU-mount misalignment angles start to heavily fluctuate with time due to the mathematical singularity occurring at these points, meaning that the IMU-mount misalignment angles output in the `UBX-ESF-ALG` are not stable in time. Note however that each individual set of IMU-mount misalignment angles output in such a case still describes the correct rotation. Moreover, the internal rotation applied for aligning the IMU readings does not suffer from this singularity issue and optimal fusion can still be achieved.

3.2.6.4 Navigation output

3.2.6.4.1 Local-level north-east-down (NED) frame

The local-level frame is a geodetic frame with the following features:

- The origin (O) is a point on the Earth's surface;
- The x-axis points to north;
- The y-axis points to east;
- The z-axis completes the right-handed reference system by pointing down.

The frame is referred to as North-East-Down (NED) since its axes are aligned with the North, East and down directions.

3.2.6.4.2 Vehicle frame

The vehicle frame is a right-handed 3D Cartesian frame rigidly connected with the vehicle and is used to determine the attitude of the vehicle with respect to the local-level frame. It has the following features:

- The origin (O) is the VRP;
- The x-axis points towards the front of the vehicle;
- The y-axis points towards the right of the vehicle;
- The z-axis completes the right-handed reference system by pointing down.

3.2.6.4.3 Vehicle position and velocity output

The position and velocity information is output in several messages, for example, `UBX-NAV-PVT`. Position and velocity computed by the ADR navigation filter are referenced to the IRP.

3.2.6.4.4 Vehicle attitude output

The transformation between the vehicle frame and the local-level frame is described by three attitude angles about the local-level axes denoted as *vehicle roll*, *vehicle pitch* and *vehicle heading*. All three angles are referred to as *vehicle attitude* and are illustrated in the figure below:

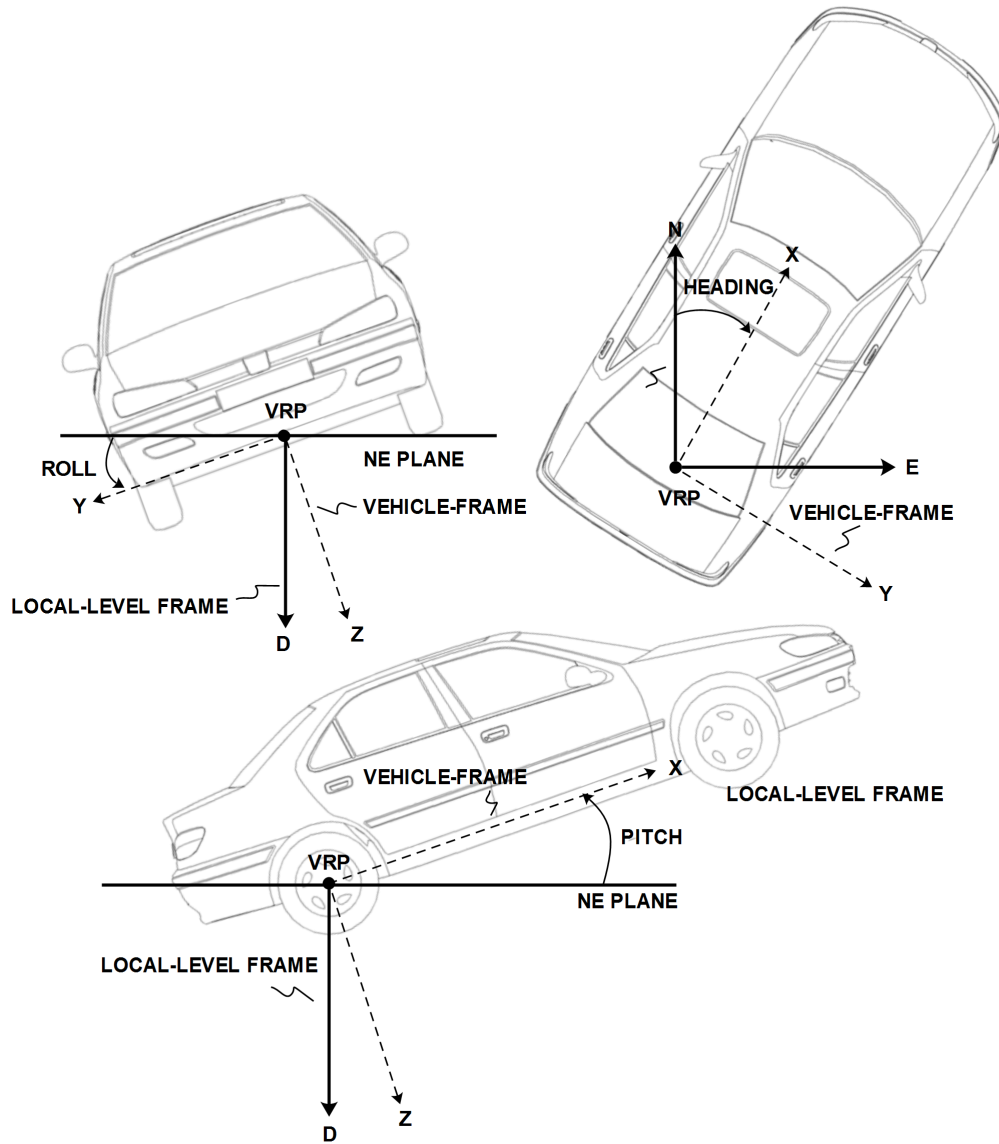

NOTES:
 N = NORTH, E = EAST, D = DOWN, IMU-FRAME ALIGNED WITH VEHICLE-FRAME

Figure 6: Vehicle attitude output

The order of the sequence of rotations around the navigation axes defining the vehicle attitude matrix in terms of vehicle attitude angles is illustrated below:

VEHICLE ATTITUDE DEFINITION

ϕ : Vehicle roll angle

θ : Vehicle pitch angle

ψ : Vehicle heading angle

C_b^n : Rotation between body-frame (b) and local-level NED navigation-frame (n)

$$C_X = \begin{bmatrix} 1 & 0 & 0 \\ 0 & \cos(\phi) & \sin(\phi) \\ 0 & -\sin(\phi) & \cos(\phi) \end{bmatrix} \quad C_Y = \begin{bmatrix} \cos(\theta) & 0 & -\sin(\theta) \\ 0 & 1 & 0 \\ \sin(\theta) & 0 & \cos(\theta) \end{bmatrix} \quad C_Z = \begin{bmatrix} \cos(\psi) & \sin(\psi) & 0 \\ -\sin(\psi) & \cos(\psi) & 0 \\ 0 & 0 & 1 \end{bmatrix}$$

$$C_b^n = C_Z^T \cdot C_Y^T \cdot C_X^T$$

$$= \begin{bmatrix} \cos(\theta) \cos(\psi) & \sin(\phi) \sin(\theta) \cos(\psi) - \cos(\phi) \sin(\psi) & \cos(\phi) \sin(\theta) \cos(\psi) + \sin(\phi) \sin(\psi) \\ \cos(\theta) \sin(\psi) & \sin(\phi) \sin(\theta) \sin(\psi) + \cos(\phi) \cos(\psi) & \cos(\phi) \sin(\theta) \sin(\psi) - \sin(\phi) \cos(\psi) \\ -\sin(\theta) & \sin(\phi) \cos(\theta) & \cos(\phi) \cos(\theta) \end{bmatrix}$$

Figure 7: Vehicle attitude definition

Note that in this figure the body frame corresponds to the vehicle frame.

The vehicle attitude is output in the UBX-NAV-ATT message. The message provides all three angles together with their accuracy estimates.

3.2.6.4.5 Vehicle dynamics output

The UBX-ESF-INS message outputs information about vehicle dynamics provided by the INS, compensated vehicle angular rates, and compensated vehicle acceleration. The acceleration data is free of any gravitational acceleration. Its accuracy is directly dependent on the filter attitude estimation accuracy.

Compensated vehicle dynamics information is output with respect to the vehicle frame.



The message outputs only dynamics information that is directly compensated by the fusion filter. This implies that depending on the solution type and the sensor availability, dynamics along some axes of the vehicle frame might not be available.

3.2.6.5 Sensor data types

The UBX-ESF-MEAS messages can be used as input and/or output messages. They can provide the following functionality:

- Output the ZED-F9K internal IMU measurements;
- Input external wheel tick or speed measurements from a host to ZED-F9K.

A different number of data fields may be used, and these can contain different types of measurements. The type of each measurement is specified in the UBX-ESF-MEAS . dataType field.

The supported sensor data types are:

Type	Description	Unit	Format of the 24 data bits
0	none, data field contains no data		
1...4	reserved		
5	z-axis gyroscope angular rate	deg/s *2 ⁻¹²	signed
6...7	reserved		

Type	Description	Unit	Format of the 24 data bits
8	rear-left wheel ticks		Bits 0-22: unsigned tick value. Bit 23: direction indicator (0=forward, 1=backward)
9	rear-right wheel ticks		Bits 0-22: unsigned tick value. Bit 23: direction indicator (0=forward, 1=backward)
10	single tick (speed tick)		Bits 0-22: unsigned tick value. Bit 23: direction indicator (0=forward, 1=backward)
11	speed	m/s * 1e-3	signed
12	gyroscope temperature	deg Celsius * 1e-2	signed
13	y-axis gyroscope angular rate	deg/s * 2 ⁻¹²	signed
14	x-axis gyroscope angular rate	deg/s * 2 ⁻¹²	signed
15	reserved		
16	x-axis accelerometer-specific force	m/s ² * 2 ⁻¹⁰	signed
17	y-axis accelerometer-specific force	m/s ² * 2 ⁻¹⁰	signed
18	z-axis accelerometer-specific force	m/s ² * 2 ⁻¹⁰	signed
19...63	reserved		

Table 15: Definition of data types

3.2.6.6 Raw sensor data output

The UBX-ESF-RAW message can be used to access raw sensor measurements. A variable number of data fields may be used in a single message and these can contain different types of measurements. The type of each measurement is specified in the `UBX-ESF-RAW.dataType` field.

The possible sensors for the `data` field are accelerometer, gyroscope and temperature readings. The data types are the same as described in the [Sensor Data Types](#) section.

The measurements are available at a fixed rate. The sampling rate or other sensor configuration options cannot be changed, they depend on the inertial sensors connected. The raw measurements are output as one sample of every data type per message.

To enable this feature, the `UBX-ESF-RAW` message must be enabled using `CFG-MSGOUT-UBX_ESF_RAW-*` keys. If any non-zero rate is selected the message will be output at the rate at which the sensors are sampled.



The feature can only be enabled if the active inertial sensors are connected to the GNSS receiver directly via hardware interface.



Turning on this feature does not disable sensor fusion in the receiver.

3.2.6.7 Receiver startup and shutdown

Continuous dead reckoning is possible over receiver restarts if all following conditions are true:

- Non-volatile storage is available, the save-on-shutdown feature (SOS), or the advanced calibration handling feature is used
- A real-time clock is available or time assistance is provided on startup
- The sensor data stream is only stopped when the vehicle is stationary
- The vehicle is not moved while the receiver is off

3.2.7 Priority navigation mode

3.2.7.1 Introduction

ZED-F9K provides a low-latency position, velocity, and vehicle attitude solution to be output at a high rate by utilizing sensor-based propagation in between GNSS-measurement updates, thus prioritizing the time-critical data.

The receiver issues priority navigation messages first, and non-priority navigation messages when time allows it. The non-priority messages might, therefore, be output with some delay.



The following tables list priority navigation messages.

UBX protocol message	Content	Priority level	Output rate
UBX-NAV-PVT	Position, velocity, heading and time data	High	0-50 Hz (Configurable)
UBX-NAV-PVAT ²	Position, velocity, attitude and time data	High	0-50 Hz (Configurable)
UBX-NAV-HPPOSECEF	High-precision position solution in ECEF	High	0-50 Hz (Configurable)
UBX-NAV-POSECEF	Position solution in ECEF	High	0-50 Hz (Configurable)
UBX-NAV-HPPOSLLH	High-precision geodetic position solution	High	0-50 Hz (Configurable)
UBX-NAV-POSLLH	Geodetic position solution	High	0-50 Hz (Configurable)
UBX-NAV-ATT	Attitude data	High	0-50 Hz (Configurable)
UBX-ESF-INS	INS data	High	0-50 Hz (Configurable)
UBX-NAV-VELECEF	ECEF velocities	High	0-50 Hz (Configurable)
UBX-NAV-VELNED	NED velocities	High	0-50 Hz (Configurable)

Table 16: UBX priority navigation messages

NMEA protocol message	Content	Priority level	Output rate
NMEA-Standard-DTM	Datum info	High	0-50 Hz (Configurable)
NMEA-Standard-RMC	Recommended minimum data	High	0-50 Hz (Configurable)
NMEA-Standard-VTG	Course over ground and ground speed	High	0-50 Hz (Configurable)
NMEA-Standard-GNS	GNSS fix data	High	0-50 Hz (Configurable)
NMEA-Standard-GGA	Global positioning system fix data	High	0-50 Hz (Configurable)
NMEA-Standard-GLL	Latitude and longitude, with time of position fix and status	High	0-50 Hz (Configurable)
NMEA-Standard-THS	True heading and status	High	0-50 Hz (Configurable)
NMEA-PUBX-POSITION	Latitude and longitude position data	High	0-50 Hz (Configurable)

Table 17: NMEA priority navigation messages

-  The ZED-F9K requires an initialization phase if the sensors have not been calibrated. During this initialization, the receiver delivers GNSS-only navigation solution data, still ensuring high-rate and low-latency output. The ZED-F9K works optimally in priority navigation mode when the IMU and WT sensors have been calibrated, and the alignment angles are correct.
-  If priority navigation mode is enabled, comparing time information of a non-priority UBX message with a priority NMEA message may not be sensible (see the [iTOW timestamps](#) section). Thus, it is recommended to compare messages with the same priority level. For instance, comparing the time information of a non-priority UBX message with a non-priority NMEA message (such as NMEA-Standard-ZDA).
-  When switching back from priority mode to non-priority mode, the TOW could jump back in time, similarly, switching from non-priority to priority mode may cause TOW to jump ahead in time.

² Supported from firmware version LAP 1.30 onwards

3.2.7.2 Configuration

You can configure the priority navigation mode output using the CFG-RATE-NAV_PRI0 configuration key.

-  If a high priority navigation rate has been configured with CFG-RATE-NAV_PRI0, it is strongly recommended to check (and maybe reduce) the number of enabled output messages. Interface bandwidth constraints may be a limiting factor.

As mentioned in the table above, the allowed range for the priority navigation mode is 0-50 Hz.

When not zero, the receiver outputs navigation data as a set of messages with two priority levels:

1. Priority navigation mode: the navigation solution data is computed and output with high rate and low latency.
2. Non-priority navigation mode: the navigation data is computed and output with low rate and high latency.

When zero, the receiver outputs the navigation data as a set of messages with the same priority level i.e. non-priority navigation mode.

3.2.8 Wake on motion feature

3.2.8.1 Introduction

-  Supported on ZED-F9K-01A from firmware version LAP 1.30 onwards

This feature utilizes the on-board IMU sensor's interrupt pin to wake up the host. Set the receiver in the software backup mode to use this feature. The software backup mode acts as a sleep mode for the receiver. IMUs are capable of sending discrete signals on acceleration events while the sensor itself could be in low power consumption mode.

3.2.8.2 Configuration

Enabling the wake on motion feature requires two configurations:

- CFG-HW-SENS_WOM_MODE: Is used to enable and set the mode of the wake on motion.
- CFG-HW-SENS_WOM_THLD: Is used to set the required acceleration on a single accelerometer axis for triggering the wake up.

With CFG-HW-SENS_WOM_MODE, the receiver can be configured with four different wake on motion modes. By default the feature is disabled so CFG-HW-SENS_WOM_MODE is set to 0. For the use cases where only the host needs to wake up, the CFG-HW-SENS_WOM_MODE should be set to 1. The receiver will output a discrete signal over the WOM pin whenever motion is detected, but the signal will not wake up the receiver. With CFG-HW-SENS_WOM_MODE set to 2, the IMU interrupt would wake up the receiver and no discrete signal will be output by the receiver over the WOM pin. The last option is where the CFG-HW-SENS_WOM_MODE is set to 3, with this mode the IMU interrupt will wake up both the receiver and output a discrete signal over the WOM pin for the host. The receiver will start normal operation afterwards.

For CFG-HW-SENS_WOM_THLD the value ranges between 1-255, where 1 corresponds to 0 g and 255 to 1 g, where $g = 9.81 \text{ m/s}^2$. e.g. for 0.25 g threshold the configured value should be 64. The default value for CFG-HW-SENS_WOM_THLD is 0, which corresponds to the threshold of 0.5 g. The threshold is configured for all axis, so if the acceleration on any axis exceeds the threshold, the IMU interrupt would be triggered and would wake up the host.

-  With the LAP 1.30 firmware, the wake on motion feature supports the host only option, i.e. CFG-HW-SENS_WOM_MODE should be set to 1. Waking up the receiver is currently not supported

3.2.8.3 Procedure to use the wake on motion feature

The following outlines the procedure when using the wake on motion feature:

- Set the required mode for the wake on motion feature via `CFG-HW-SENS_WOM_MODE`.
- Depending on the use case, set the required threshold for a single accelerometer axis via `CFG-HW-SENS_WOM_THLD`.
- Set the desired configuration to all layers and send it to the receiver.
- Afterwards, power cycle the receiver. This will initialize the sensors for wake on motion feature. This only needs to be done once the wake on motion configuration is changed.
- The next step is to set the receiver in software backup mode. The receiver can be set to software backup mode via `UBX-RXM-PMREQ` message. Duration of the requested task should be set to zero.
- Afterwards, based on the threshold and the mode the IMU interrupt would wake up the configured interface.



In `UBX-RXM-PMREQ` message the `wakeupSources.extint0` flag should not be disabled for the wake on motion feature.



The test setup should be equivalent to the final mechanical design to account for damping effects, as the detection threshold will vary depending on the place of installation / dampening.

3.2.8.4 Example use cases

The following `CFG-HW-SENS_WOM_THLD` values correspond to the bare minimum acceleration that would be produced in each scenario and should be used as a guideline, the specific thresholds will depend significantly on the final installation:

- Opening the door and entering the car: 15 (0.06 g)
- Starting the vehicle and driving out slowly: 25 (0.1 g)
- A bump on a parked car: 50 (0.2 g)
- Hard stopping the vehicle: 200 (0.78 g)

3.3 Primary and secondary output



Supported from firmware version LAP 1.30 onwards

3.3.1 Introduction

u-blox GNSS receivers output various navigation results and data calculated as part of the navigation solution. These include results such as position, altitude, velocity, status flags, accuracy estimate figures, satellite/signal information and more.

The ZED-F9K can provide this output in two streams:

- **Primary output:** Reports the results of a full navigation solution using all capabilities of the ZED-F9K, such as, for example, lane accurate sensor fusion positioning.
- **Secondary output:** Reports the results of a GNSS standalone navigation solution.

Both the primary output and secondary output provide a similar set of information but the two outputs report different results. The primary output is reported in the form of `UBX-NAV-*` messages, while the secondary output is reported in the form of `UBX-NAV2-*` messages. Therefore, the `UBX` message class can be used to distinguish between the primary output and the secondary output. For the specification of the `UBX-NAV2-*` messages and for a full list of available `UBX-NAV2-*` messages, see the applicable interface description [2].



The secondary output may also be available as `NMEA-NAV2-*` messages. To confirm availability of `NMEA-NAV2-*` messages, see the applicable interface description [2]. `NMEA-NAV2-*`

messages can only be output if the configured NMEA version is NMEA 4.0 or later. For simplicity this section refers only to UBX-NAV2-* messages but the same information applies for NMEA-NAV2-* messages.



The secondary output is complementary to the primary output. It does not provide the full navigation solution of the primary output. It can be used to expand the applications of the ZED-F9K to enable using a second navigation solution in parallel with the primary navigation solution.

The rest of this section describes how to configure and use the secondary output, what is the expected output behavior, and provides examples that illustrate potential uses for the secondary output, while highlighting the differences between the primary and the secondary output.

3.3.2 Configuration

Configuring the secondary output to the application's needs requires:

- Enabling the secondary output
- Configuring the desired secondary output UBX-NAV2-* messages
- Optionally, configuring the properties of the secondary output navigation solution

The configuration items relevant to the secondary output are in the CFG-NAV2-* configuration group. The configuration items for enabling and configuring the output rate of the UBX-NAV2-* messages are in the CFG-MSGOUT-* group and are of the form CFG-MSGOUT-UBX_NAV2_*. An example set of secondary output configuration items is shown in the table below. For all available configuration items, see the applicable interface description [2].

Configuration item	Description
CFG-NAV2-OUT_ENABLED	Enables secondary output
CFG-NAV2-SBAS_USE_INTEGRITY	Enables using SBAS integrity information in the secondary output
CFG-MSGOUT-UBX_NAV2_PVT_*	Enables UBX-NAV2-PVT secondary output message
CFG-MSGOUT-UBX_NAV2_TIMEGPS_*	Enables UBX-NAV2-TIMEGPS secondary output message

Table 18: Example secondary output configuration items

Enabling the secondary output: The first necessary step to enable the secondary output is to configure the CFG-NAV2-OUT_ENABLED configuration item appropriately. This will enable the secondary output navigation solution to run in parallel with the primary output navigation solution. By default, the secondary output is disabled. Note that if you do not follow the next step, there will be no secondary output visible in the ZED-F9K communication interfaces in the form of UBX-NAV2-* messages.



Both primary and secondary output report a navigation solution computed at the same navigation rate. Enabling the secondary output may affect the maximum achievable navigation update rate due to the extra computational load.

Configuring the desired secondary output UBX-NAV2-* messages: The second necessary step is to configure the desired CFG-MSGOUT-UBX_NAV2_* configuration items appropriately. These set the message output rates for the UBX-NAV2-* messages that you wish to output. By default, all UBX-NAV2-* message output rates are set to 0 and as such are not being output.



Due to the increased message output, the interface load will be higher while the secondary output messages are enabled. Therefore, the interface baud rate may need to be adapted accordingly. Alternatively, it is possible to configure the UBX-NAV2-* messages with a different output rate from that of their primary output UBX-NAV-* counterparts.

Configuring the properties of the secondary output navigation solution: Optionally, it is possible to configure the properties of the secondary output navigation solution in order to adapt it to the application's needs.

A minimal subset of the primary output navigation solution configuration is available for the secondary output navigation solution configuration. All such available configuration items are in the CFG-NAV2-* configuration group (see applicable interface description [2]).

Configuring any of the CFG-NAV2-* configuration items changes the behavior of the secondary output navigation solution only and not the primary output one. All such configuration items have a primary output configuration counterpart and have the same default value as their primary output configuration counterpart.



For example, the CFG-NAV2-SBAS_USE_INTEGRITY configuration item allows configuring the SBAS integrity feature differently for the primary output and the secondary output. Its primary output counterpart is the CFG-SBAS-USE_INTEGRITY configuration item and the default value of both configuration items is the same.

3.3.3 Expected output behavior

Once the secondary output is enabled and the desired secondary output UBX-NAV2-* messages are configured, the ZED-F9K will output both primary and secondary output data in the form of the enabled UBX-NAV-* and UBX-NAV2-* messages respectively.

In every navigation epoch, a set of UBX-NAV-* messages will be output followed by another set of UBX-NAV2-* messages. Both sets will be referring to the navigation solution of the same navigation epoch.

Each set will be delimited at its end with a UBX-NAV-EOE or a UBX-NAV2-EOE message respectively. In other words, a UBX-NAV-EOE message will be output at the end of the UBX-NAV-* class enabled messages and a UBX-NAV2-EOE message will be output at the end of the UBX-NAV2-* class enabled messages. For example, if only UBX-NAV-PVT, UBX-NAV2-PVT, UBX-NAV-TIMEGPS and UBX-NAV2-TIMEGPS are enabled on the same port with message output rate 1, then every navigation epoch output will be as follows: UBX-NAV-PVT, UBX-NAV-TIMEGPS, UBX-NAV-EOE, UBX-NAV2-PVT, UBX-NAV2-TIMEGPS, UBX-NAV2-EOE.

-  Secondary output messages appear after the primary output messages. This results in a higher latency for the secondary output messages than the primary output messages.
-  Contrary to UBX-NAV2-* messages, secondary output NMEA-NAV2-* messages are not delimited by an NMEA-equivalent to UBX-NAV-EOE.

The specification of the UBX-NAV2-* messages resembles that of the UBX-NAV-* messages. The payload specification of a UBX-NAV2 message is identical to the payload specification of its UBX-NAV counterpart, allowing to easily adapt any existing message parsers. The primary output will contain results and data reflecting the full navigation solution of the ZED-F9K. The secondary output will contain results and data reporting a GNSS standalone navigation solution.

3.3.4 Example use cases

As an example, an application using a ZED-F9K that is operating in RTK sensor fusion mode can enable the secondary output and monitor a GNSS standalone solution to understand the improvements introduced by using lane accurate sensor fusion.

3.4 Protection level

Supported from firmware version LAP 1.30 onwards

3.4.1 Introduction

Critical applications need to know how much trust they can place in their GNSS receiver's output at any given moment. Computed by the GNSS receiver in real-time, the protection level (PL) quantifies the reliability of the position information, to allow systems to change their mode of operation to improve the efficiency and quality of the tasks being performed.

The GNSS receiver's protection level describes the maximum likely position error to a specified degree of confidence. For example, if a GNSS receiver determines its position with a 95% protection level of one meter, there is only a 5% chance that the reported position is more than one meter away from its true position. Like the accuracy estimate of the GNSS receiver, the protection level constantly fluctuates, influenced by all the common error sources that affect GNSS solutions. Unlike the accuracy estimate, the confidence level of the protection level is much higher and is validated against specific operating scenarios to ensure that the output bounds the true error.

Currently the protection level is limited to L1 L2 band configuration only.

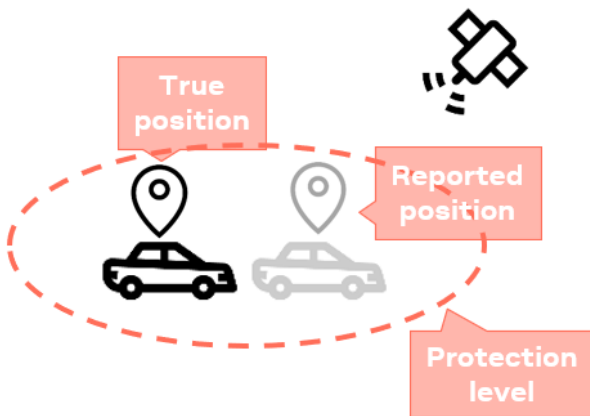

Figure 8: PL bounding true position error

3.4.2 Interface

The protection level bounds the true position error with a target misleading information risk (TMIR), for example 5[%MI/epoch] (read: 5% probability of having an MI per epoch). The target misleading information risk describes the probability per epoch of having misleading information (MI), that is, the true position error is larger than the protection level and fails to bound the true position error (see [Figure 9](#)).

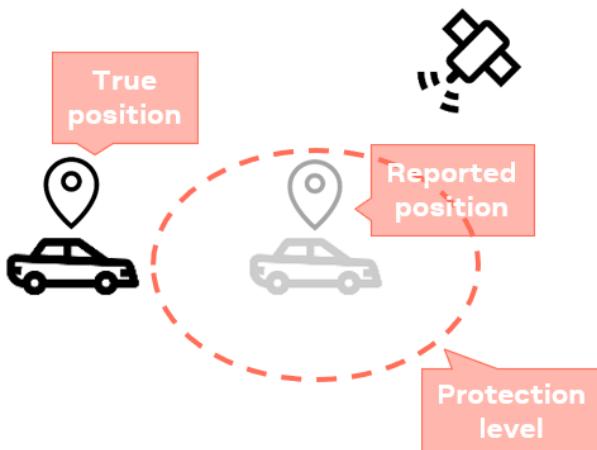

Figure 9: Misleading information

The output of the protection level is published through the UBX-NAV-PL message.

- ☞ Protection level computing can be disabled through the CFG-NAVSPG-PL_ENA configuration item. See the applicable interface description [2] for availability of the configuration item.
- ☞ TMIR is specified in one dimension for PL. It is not specified as a horizontal 2D or 3D value.
- ☞ The protection level values (UBX-NAV-PL.pIPos1/2/3) are confidence intervals around the reported position (for example, UBX-NAV-PVT or UBX-NAV-HPPOSLLH).
- ☞ The target misleading information risk is provided in exponential notation (UBX-NAV-PL.tmirCoeff and UBX-NAV-PL.tmirExp), for example UBX-NAV-PL.tmirCoeff=5 and UBX-NAV-PL.tmirExp=0 results in $5e0$ (= 5).

The user may have a threshold defined for the largest acceptable position error for their application. This threshold is known as the Alert Limit. If the reported PL exceeds this threshold, the user shall consider changing the mode of operation of the system or in the worst case declare the system unavailable. Examples of a change in the operating mode of the system could be stopping, reversing the direction of operation, slowing down or calculating a new acceptable error threshold appropriate to the mode of operation. This state is also known as the receiver being unavailable (see [Figure 10](#)).

In case the PL is smaller than the alert limit, the receiver is said to be available (see [Figure 10](#)).

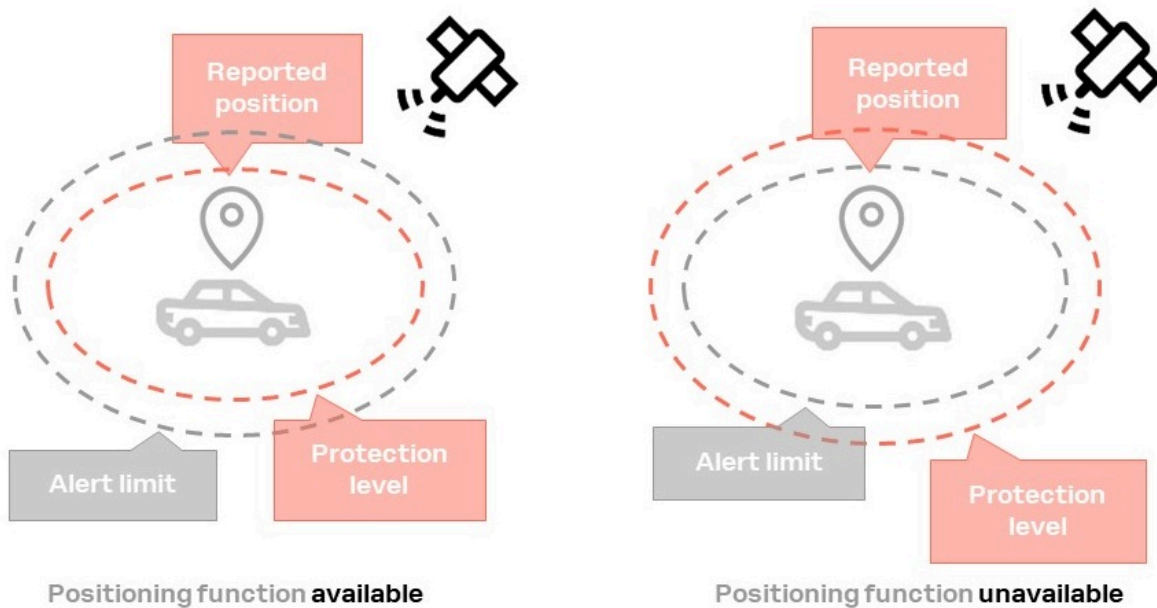

Figure 10: Positioning function

True position error is generally unknown, unless a very accurate and reliable truth positioning system is reporting an estimate for the true position

When the GNSS environment deviates significantly from the normal mode of operation as compared to scenarios where the PL has been validated, a validity flag is set to false to indicate these conditions. These conditions tend to be binary in nature, such as jamming has been detected, or the minimum number of satellites is being observed. UBX-NAV-PL reports a PL validity flag (see UBX-NAV-PL.pIPosValid), which indicates whether the PL is usable. This mechanism is not depicted in Figure 10.

The protection level performance depends on many external and internal factors. Some external factors such as the harsh GNSS environment, correction data, etc. may lead to degraded PL performance.

The protection level validity is not to be confused with misleading information and is independent of misleading information.

PL validity values	Description
UBX-NAV-PL.pIPosValid = 1	PL values are valid and can be used
UBX-NAV-PL.pIPosValid = 0	PL values are invalid and shall not be used

Table 19: Position PL validity

3.4.3 Expected behavior

For each navigation epoch and for each coordinate axis, a PL value is provided. The coordinate frame reported is horizontal-ellipse-vertical, then the UBX-NAV-PL contents can be interpreted as follows:

PL values	Description
UBX-NAV-PL.pIPos1	1 stands for the semi-major axis
UBX-NAV-PL.pIPos2	2 stands for the semi-minor axis
UBX-NAV-PL.pIPos3	3 stands for the vertical axis

PL values	Description
UBX-NAV-PL.pIPosHorizOrient	Orientation of semi-major axis w.r.t North (clockwise)

Table 20: Position PL values

If the PL coordinate frame is set to invalid (UBX-NAV-PL.pIPosFrame = 0), then the PL values shall not be used. If the PL validity flag is cleared (UBX-NAV-PL.pIValid = 0), the PL values shall not be used. Both must be checked.

Only if the PL is set to valid (UBX-NAV-PL.pIPosValid), the PL values (UBX-NAV-PL.pIPos1/2/3 and UBX-NAV-PL.pIPosHorizOrient) can be used and are reliable with respect to the target misleading information risk.

3.5 Communication interfaces

u-blox receivers are equipped with a communication interface³ which is multi-protocol capable. The interface ports can be used to transmit GNSS measurements, monitor status information and configure the receiver.

A protocol (e.g. UBX, NMEA) can be assigned to several ports simultaneously, each configured with individual settings (e.g. baud rate, message rates, etc.). More than one protocol (e.g. UBX protocol and NMEA) can be assigned to a single port (multi-protocol capability), which is particularly useful for debugging purposes.

The ZED-F9K provides UART1, UART2, SPI, I2C and USB interfaces for communication with a host CPU. The interfaces are configured via the configuration methods described in the applicable interface description [2].

The following table shows the port numbers reported in the UBX-MON-COMMS messages.

Port no.	UBX-MON-COMMS portId	Electrical interface
0	0x0000	I2C
1	0x0100	UART1
-	0x0101	Reserved
-	0x0200	Reserved
2	0x0201	UART2
3	0x0300	USB
4	0x0400	SPI

Table 21: Port number assignment

It is important to isolate interface pins when VCC is removed. They can be allowed to float or they can be connected to a high impedance.

Example isolation circuit is shown below.

³ The signal names and related terms have been replaced with new terminology in this document.

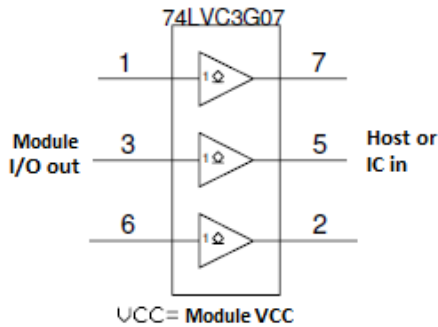

Figure 11: ZED-F9K output isolation

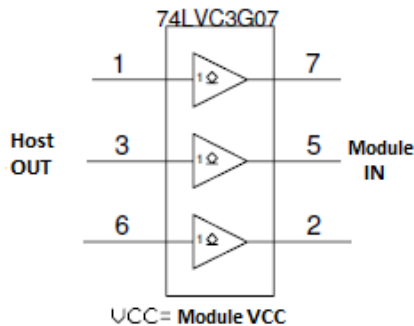

Figure 12: ZED-F9K input isolation

3.5.1 UART

A Universal Asynchronous Receiver/Transmitter (UART) port consists of an RX and a TX line. Neither handshaking signals nor hardware flow control signals are available. The UART interface protocol and baud rate can be configured but there is no support for setting different baud rates for reception and transmission.

The ZED-F9K includes two UART serial ports. UART1 can be used as a host interface for configuration, monitoring and control. UART2 is available as an optional stand-alone RTCM interface and cannot be used as a host interface.

The UART RX interface will be disabled when more than 100 frame errors are detected during a one-second period. This can happen if the wrong baud rate is used or the UART RX pin is grounded. An error message appears when the UART RX interface is re-enabled at the end of the one-second period.

Baud rate	Data bits	Parity	Stop bits
9600	8	none	1
19200	8	none	1
38400	8	none	1
57600	8	none	1
115200	8	none	1

Baud rate	Data bits	Parity	Stop bits
230400	8	none	1
460800	8	none	1
921600	8	none	1

Table 22: Possible UART interface configurations

 The default baud rate is 38400 baud. To prevent buffering problems it is recommended not to run at a lower baud rate than the default.

Allow a short time delay of typically 100 ms between sending a baud rate change message and providing input data at the new rate. Otherwise some input characters may be ignored or the port could be disabled until the interface is able to process the new baud rate.

Note that for protocols such as NMEA or UBX, it does not make sense to change the default word length values (data bits) since these properties are defined by the protocol and not by the electrical interface.

If the amount of data configured is too much for a certain port's bandwidth (e.g. all UBX messages output on a UART port with a baud rate of 9600), the buffer will fill up. Once the buffer space is exceeded, new messages to be sent will be dropped. To prevent message loss, the baud rate and communication speed or the number of enabled messages should be carefully selected so that the expected number of bytes can be transmitted in less than one second.

3.5.2 I2C interface

An I2C interface is available for communication with an external host CPU or u-blox cellular modules in peripheral mode only. The I2C protocol and electrical interface supports the Fast-mode of the I2C industry standard with a maximum SCL clock frequency of 400 kHz. Backwards compatibility with Standard-mode I2C bus operation is not supported.

The SCL and SDA pins have internal pull-up resistors which should be sufficient for most applications. However, depending on the speed of the host and the load on the I2C lines additional external pull-up resistors may be necessary.

 To use the I2C interface D_SEL pin must be left open.

 In designs where the host uses the same I2C bus to communicate with more than one u-blox receiver, the I2C peripheral address for each receiver must be configured to a different value. Typically most u-blox receivers are configured to the same default I2C peripheral address value. To poll or set the I2C peripheral address, use the CFG-I2C-ADDRESS configuration item (see the applicable interface description [2]).

The CFG-I2C-ADDRESS configuration item is an 8-bit value containing the I2C peripheral address in 7 most significant bits, and the read/write flag in the least significant bit.

3.5.2.1 I2C register layout

The I2C interface allows 256 registers to be addressed. As shown in [Figure 13](#), only three of these are currently implemented.

The data registers 0 to 252 at addresses 0x00 to 0xFC contain reserved information, the result from their reading is currently undefined. The data registers 0 to 252 are 1 byte wide.

At addresses 0xFD and 0xFE it is possible to read the currently available number of bytes.

The register at address 0xFF allows the data stream to be read. If there is no data awaiting transmission from the receiver, then this register delivers value 0xFF, which cannot be the first byte

of a valid message. If the message data is ready for transmission, the successive reads of register 0xFF will deliver the waiting message data.



Do not use registers 0x00 to 0xFC. They are reserved for future use and they do not currently provide any meaningful data.

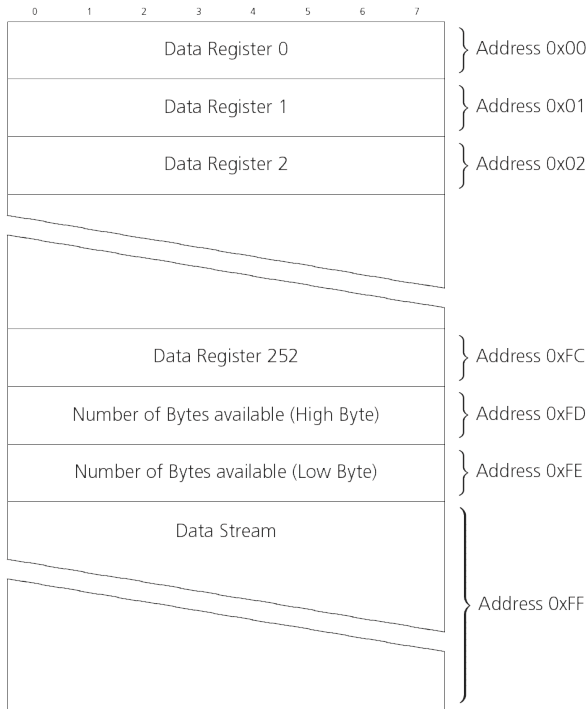

Figure 13: I2C register layout

3.5.2.2 Read access types

There are two I2C read transfer forms:

- The "random access" form: includes a peripheral register address and allows any register to be read.
- The "current address" form: omits the register address.

Figure 14 shows the format of the first one, the "random access" form of the request. Following the start condition from the controller, the 7-bit device address and the RW bit (which is a logic low for write access) are clocked onto the bus by the controller transmitter. The receiver answers with an acknowledge (logic low) to indicate that it recognizes the address.

Next, the 8-bit address of the register to be read must be written to the bus. Following the receiver's acknowledgment, the controller again triggers a start condition and writes the device address, but this time the RW bit is a logic high to initiate the read access. Now, the controller can read 1 to N bytes from the receiver, generating a not-acknowledge and a stop condition after the last byte being read.

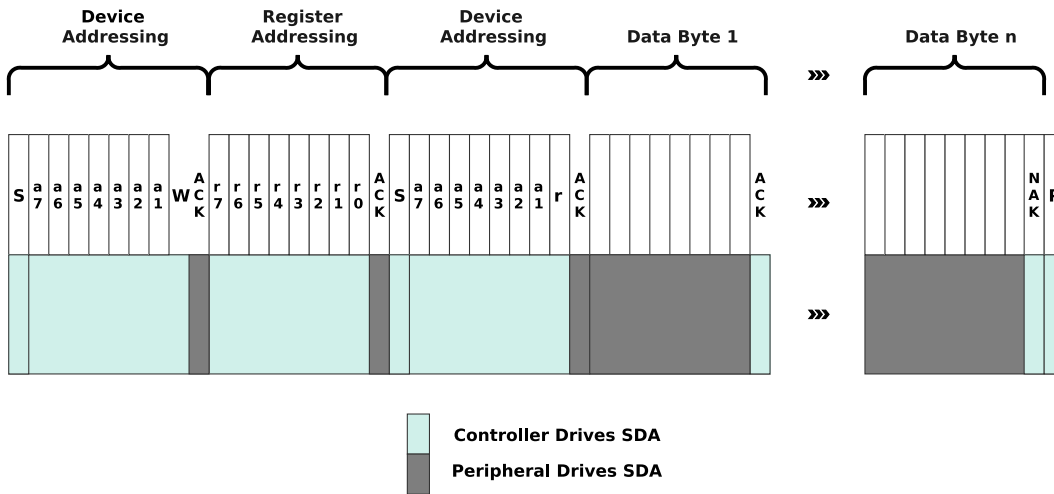

Figure 14: I2C random read access

If the second form, "current address" is used, an address pointer in the receiver is used to determine which register to read. This address pointer will increment after each read unless it is already pointing at register 0xFF, the highest addressable register, in which case it remains unaltered.

The initial value of this address pointer at startup is 0xFF, so by default all current address reads will repeatedly read register 0xFF and receive the next byte of message data (or 0xFF if no message data is waiting).

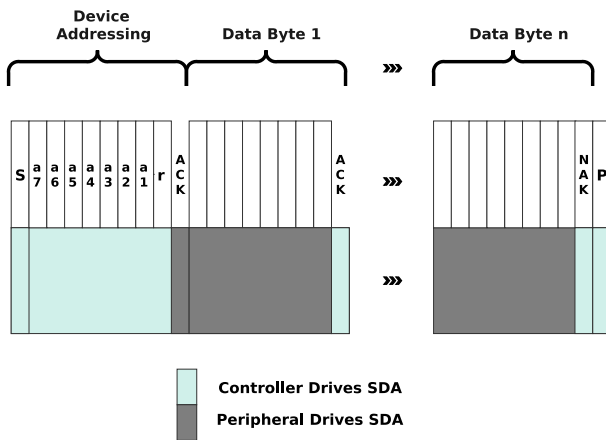

Figure 15: I2C current address read access

3.5.2.3 Write access

The receiver does not provide any write access except for writing UBX and NMEA messages to the receiver, such as configuration or aiding data. Therefore, the register set mentioned in the section [Read access](#) is not writable.

Following the start condition from the controller, the 7-bit device address and the RW bit (which is a logic low for write access) are clocked onto the bus by the controller transmitter. The receiver answers with an acknowledge (logic low) to indicate that it is responsible for the given address.

The controller can write 2 to N bytes to the receiver, generating a stop condition after the last byte being written. The number of data bytes must be at least 2 to properly distinguish from the write access to set the address counter in random read accesses.

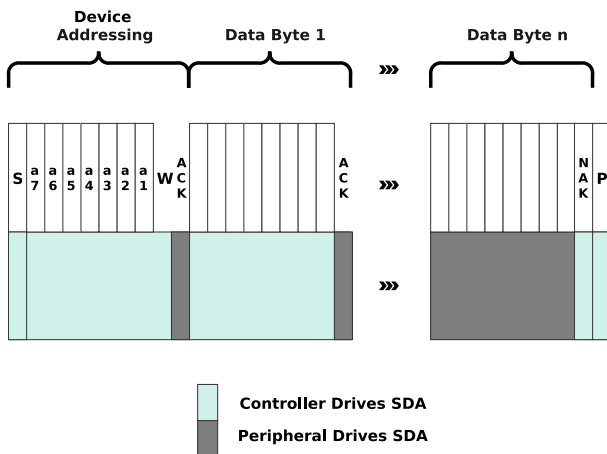

Figure 16: I2C write access

3.5.3 SPI interface

ZED-F9K has an SPI peripheral interface that can be selected by setting `D_SEL = 0`. The SPI peripheral interface is shared with UART1 and I2C port, the physical pins are same. The SPI pins available are:

- SPI_SDO (TXD)
- SPI_SDI (RXD)
- SPI_CS_N
- SPI_CLK

See more information about communication interface selection from the [D_SEL](#) section.

The SPI interface is designed to allow communication to a host CPU. The interface can be operated in peripheral mode only.

3.5.3.1 Read access

As the register mode is not implemented for the SPI port, only the UBX/NMEA message stream is provided. This stream is accessed using the back-to-back read and write access (see section [Back-to-back read and write access](#) below). When no data is available to be written to the receiver, SDI should be held logic high, i.e. all bytes written to the receiver are set to 0xFF.

To prevent the receiver from being busy parsing incoming data, the parsing process is stopped after 50 subsequent bytes containing 0xFF. The parsing process is re-enabled with the first byte not equal to 0xFF.

If the receiver has no more data to send, it sets SDO to logic high, i.e. all bytes transmitted decode to 0xFF. An efficient parser in the host will ignore all 0xFF bytes which are not part of a message and will resume data processing as soon as the first byte not equal to 0xFF is received.

3.5.3.2 Back-to-back read and write access

The receiver does not provide any write access except for writing UBX and NMEA messages to the receiver, such as configuration or aiding data. For every byte written to the receiver, a byte will simultaneously be read from the receiver. While the controller writes to SDI of the peripheral, at the same time it needs to read from SDO of the peripheral, as any pending data will be output by the receiver with this access. The data on SDO represents the results from a current address read, returning 0xFF when no more data is available.

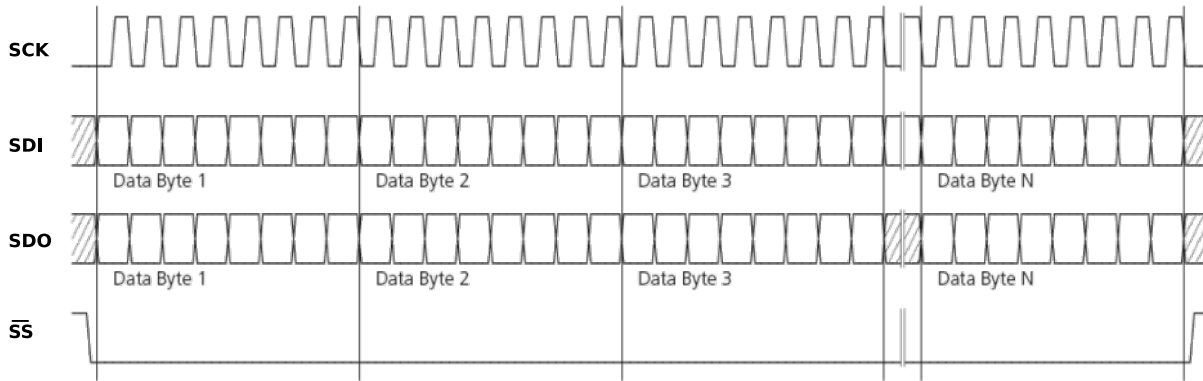

Figure 17: SPI back-to-back read/write access





3.5.4 USB interface

A single USB port is provided for host communication purposes.

The USB 2.0 FS (Full speed, 12 Mbit/s) interface can be used for host communication. Due to the hardware implementation, it may not be possible to certify the USB interface.

If the receiver executes code from internal ROM (i.e. when a valid flash firmware image is not detected), the USB behavior can differ compared to executing a firmware image from flash memory. USB host compatibility testing is thus recommended in this scenario.

The ZED-F9K receiver supports only self-powered mode operation in which the receiver is supplied from its own power supply. The V_{USB} pin is used to detect the availability of the USB port, i.e. whether the receiver is connected to a USB host.

-  USB suspend mode is not supported.
-  USB bus-powered mode is not supported.
-  It is important to connect V_{USB} to ground and leave data lines open when the USB interface is not used in an application.
-  The voltage range for V_{USB} is specified from 3.0 V to 3.6 V, which differs slightly from the specification for VCC.
-  The boot screen is retransmitted on the USB port after enumeration. However, messages generated between receiver startup and USB enumeration are not visible on the USB port.

There are additional hardware requirements if USB is used:

- V_{USB} (pin 38) requires 1 uF capacitor mounted adjacent to the pin to ensure correct V_{USB} voltage detection
- The V_{USB} (Pin 38) voltage should be sourced from an LDO enabled by the module VCC and supplied from the USB host.
- A pull-down resistor is required on the output of this V_{USB} LDO
- Apply USB_DM and USB_DP series resistors; typically 27 Ω

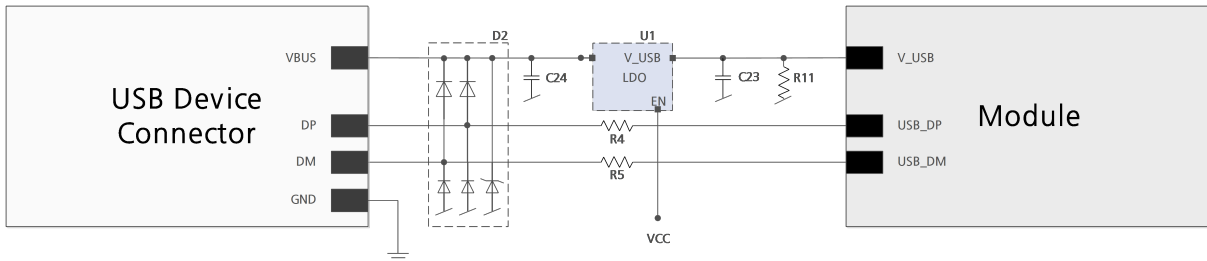

Figure 18: ZED-F9K example circuit for USB interface

R11 = 100 k Ω is recommended

R4, R5 = 27 Ω is recommended

3.5.5 Interface tunneling

Supported from firmware version LAP 1.30 onwards

3.5.5.1 Introduction

ZED-F9K supports interface tunneling. When interface tunneling is configured and enabled, any input on a configured ZED-F9K interface A (i.e. UART 1 in this release) will not get processed by the ZED-F9K and instead forwarded to interface B (i.e. UART 2 in this release) as an output from ZED-F9K for connected peripheral device.

Moreover, it is possible to configure and enable multiple interface. For example, interface tunneling from interface A to interface B can be in parallel to interface tunneling from interface B to interface A. Assuming a host application connected on interface A, this scheme can be utilized by a host application to effectively bypass the ZED-F9K and have a full two-way communication with a peripheral device connected on interface B.

- Interface tunneling is currently available only between the UART1 and the UART2 interfaces
- A host application cannot use interface tunneling to communicate simultaneously with both the ZED-F9K and the peripheral device.
- Despite the availability of interface tunneling, it is recommended to not rely exclusively on interface tunneling as the only way to communicate with the peripheral device. It is recommended that an extra interface is available on the application design between the host application and the peripheral device for configuration or debugging purposes.

3.5.5.2 Configuration

To configure and enable or disable interface tunneling the following steps in [Table 23](#) must be followed. The following steps apply in the case of interface tunneling from the UART1 of ZED-F9K to the UART2 of ZED-F9K and vice versa. It is assumed that the host application is connected to the UART1 of ZED-F9K.

- For a simpler example, the following steps in [Table 23](#) assume that the host application is connected to the ZED-F9K UART1 and that the peripheral device is a u-blox NEO-D9S receiver connected to ZED-F9K UART2

Step	Example/Notes
Ensure baud rate of ZED-F9K UART2 is the same as the baud rate of NEO-D9S UART	<p>The steps in this table assume that the NEO-D9S UART baud rate is known and is the same as the ZED-F9K UART2 baud rate.</p> <p>If the NEO-D9S UART baud rate is known and is different than the ZED-F9K UART2 baud rate:</p> <ul style="list-style-type: none"> • configure the ZED-F9K UART2 baud rate directly to match the NEO-D9S UART baud rate • or configure the NEO-D9S UART baud rate to match the ZED-F9K UART2 baud rate. To do so, refer to the steps in Table 24 to change the NEO-D9S UART baud rate through the ZED-F9K
Minimize output load of ZED-F9K UART1 and ZED-F9K UART2 <ul style="list-style-type: none"> • CFG-UART1-OUTPROT-UBX = 0 • CFG-UART1-OUTPROT-NMEA = 0 • CFG-UART1-OUTPROT-RTCM = 0 • CFG-UART2-OUTPROT-UBX = 0 • CFG-UART2-OUTPROT-NMEA = 0 • CFG-UART2-OUTPROT-RTCM = 0 	<p>Once configured, there will be no periodic output seen on ZED-F9K UART1/2</p> <ul style="list-style-type: none"> • Despite that, the ZED-F9K navigation engine still operates and message polling is still possible • Some of the CFG-UART1/2-OUTPROT-* configuration items shown here may already be set to false in the default configuration of ZED-F9K
Enable interface tunneling from ZED-F9K UART1 to ZED-F9K UART2 and vice versa <ul style="list-style-type: none"> • CFG-UART1-TUNNEL = UART2 • CFG-UART2-TUNNEL = UART1 	<p>Once configured, any input on ZED-F9K UART1 will not be processed by ZED-F9K. Instead it will be tunneled and output on ZED-F9K UART2. Once configured, any input on ZED-F9K UART2 will not be processed by ZED-F9K. Instead it will be tunneled and output on ZED-F9K UART1. In other words, the host application can now communicate directly with the NEO-D9S through the ZED-F9K.</p> <p>Communication with ZED-F9K is now not possible using UART1 or UART2, until the interface tunneling is disabled or until the ZED-F9K power cycles and reverts to its previous configuration. Other interfaces may be used to communicate directly with ZED-F9K.</p> <ul style="list-style-type: none"> • UBX-CFG-VALSET binary string to set CFG-UART1-TUNNEL to UART2 and CFG-UART2-TUNNEL to UART1 (RAM layer): b5 62 06 8a 0e 00 00 01 00 00 0a 00 52 20 03 0a 00 53 20 02 9d d6 • UBX-CFG-VALSET binary string to set CFG-UART2-TUNNEL to UART1 (RAM layer): b5 62 06 8a 09 00 00 01 00 00 0a 00 53 20 02 19 9e • UBX-CFG-VALSET binary string to set CFG-UART1-TUNNEL to UART2 (RAM layer): b5 62 06 8a 09 00 00 01 00 00 0a 00 52 20 03 19 9c • Note: Only known protocol supported by ZED-F9K are tunneled. Arbitrary binary messages is not supported by the tunnel. • Note: It is recommended to configure both configuration items in a single UBX-CFG-VALSET message to avoid enabling UART1 tunneling before UART2 tunneling is enabled • Note: It is recommended to apply this configuration in the RAM configuration layer to allow reverting by power cycling
Confirm communication with the NEO-D9S through the ZED-F9K <ul style="list-style-type: none"> • For example, poll UBX-MON-VER 	<ul style="list-style-type: none"> • After polling, the host application should receive a UBX-MON-VER reply from the NEO-D9S • Note: This is not a necessary step. It is recommended to confirm communication before proceeding
Configure the NEO-D9S through the ZED-F9K <ul style="list-style-type: none"> • For example, enable UBX-MON-PMP output on NEO-D9S 	<ul style="list-style-type: none"> • Once the host sends the configuration message to enable UBX-MON-PMP output on NEO-D9S (CFG-MSGOUT-UBX_MON_PMP_UART1 = 1), it receives a UBX-ACK-ACK from the NEO-D9S • Then the host application receives the UBX-MON-PMP periodic output of NEO-D9S • Note: Configuring the NEO-D9S is not a necessary step. This is only used here as an example

Step	Example/Notes
Update the NEO-D9S through the ZED-F9K <ul style="list-style-type: none"> For example, the firmware update process can be run 	The firmware update process usually involves baud rate changes to speed up the process. Any baud rate changes, while interface tunneling is enabled, will stop successful communication between the ZED-F9K UART2 and the NEO-D9S UART. This will cause the firmware update process to fail. To avoid this: <ul style="list-style-type: none"> ensure the firmware update process does not change the baud rate or adapt the firmware update process to change the baud rate as in Table 24 Note: Updating the NEO-D9S is not a necessary step. This is only used here as an example
Disable interface tunneling from ZED-F9K UART1 to ZED-F9K UART2 and vice versa <ul style="list-style-type: none"> CFG-UART1-TUNNEL = DISABLED CFG-UART2-TUNNEL = DISABLED 	<ul style="list-style-type: none"> Example UBX-CFG-VALSET binary string to set CFG-UART1-TUNNEL to DISABLED and CFG-UART2-TUNNEL to DISABLED (RAM layer): b5 62 06 8a 0e 00 00 01 00 00 0a 00 52 20 00 0a 00 53 20 00 98 c2 Once interface tunneling is disabled, the host loses communication with the NEO-D9S and can only communicate with the ZED-F9K Once interface tunneling is disabled, any input on the ZED-F9K UART1 and UART2 will be getting processed again by the ZED-F9K Note: To disable interface tunneling the exact binary string as presented here must be sent
Restore output load of ZED-F9K UART1 and ZED-F9K UART2 <ul style="list-style-type: none"> CFG-UART1-OUTPROT-UBX CFG-UART1-OUTPROT-NMEA CFG-UART1-OUTPROT-RTCM CFG-UART2-OUTPROT-UBX CFG-UART2-OUTPROT-NMEA CFG-UART2-OUTPROT-RTCM 	<ul style="list-style-type: none"> Once configured there will be periodic output seen on ZED-F9K UART1 and ZED-F9K UART2 Note: Not all periodic output is necessary to restore on all ports. The enabled protocols per port depend on the host application needs. This is only used here as an example

Table 23: Interface tunneling example steps: Host application communicating and setting up the NEO-D9S through the ZED-F9K

The host application may need to configure the baud rate of the NEO-D9S UART to a different one. This may be needed for a variety of reasons, for example, to support higher output load on the NEO-D9S, to perform a faster NEO-D9S firmware download, etc.

Step	Example/Notes
Ensure baud rate of ZED-F9K UART2 is the same as the baud rate of NEO-D9S UART	Same as described in Table 23
Minimize output load of ZED-F9K UART1 and ZED-F9K UART2	Same as described in Table 23
Enable interface tunneling from ZED-F9K UART1 to ZED-F9K UART2 and vice versa	Same as described in Table 23
Confirm communication with the NEO-D9S through the ZED-F9K	Same as described in Table 23
Change the NEO-D9S UART1 baud rate through the ZED-F9K <ul style="list-style-type: none"> Set CFG-UART1-BAUDRATE to desired baud rate B 	Once the host sends the configuration message to change the NEO-D9S UART1 baud rate, the communication between the ZED-F9K UART2 and NEO-D9S UART1 is no longer possible due to different baud rates. Hence successful communication to the NEO-D9S through the ZED-F9K is no longer possible.
Disable interface tunneling from ZED-F9K UART1 to ZED-F9K UART2 and vice versa	Same as described in Table 23
Set the ZED-F9K UART2 baud rate to B <ul style="list-style-type: none"> Set CFG-UART2-BAUDRATE to same baud rate B 	Once the host sends the configuration message to change the ZED-F9K UART2 baud rate, the communication between the ZED-F9K UART2 and NEO-D9S UART1 is again possible. Hence successful communication to the NEO-D9S through the ZED-F9K is once again possible.
Enable interface tunneling from ZED-F9K UART1 to ZED-F9K UART2 and vice versa	Same as described in Table 23
Confirm communication with the NEO-D9S through the ZED-F9K	Same as described in Table 23 . Success indicates both NEO-D9S UART1 and ZED-F9K UART2 baud rates are successfully configured and matching

Step	Example/Notes
Disable interface tunneling from ZED-F9K UART1 to ZED-F9K UART2 and vice versa	Same as described in Table 23
Restore output load of ZED-F9K UART1 and ZED-F9K UART2	Same as described in Table 23

Table 24: Interface tunneling example steps: Host application can adjust the baud rate of NEO-D9S through the ZED-F9K

3.6 Predefined PIOs

In addition to the communication ports, there are some predefined PIOs provided by ZED-F9K to interact with the receiver. These PIOs are described in this section.



If hardware backup mode is used a proper isolation of the interfaces is needed.

3.6.1 D_SEL

The D_SEL pin can be used to configure the functionality of the combined UART1, I2C, and SPI pins. It is possible to configure the pins as UART1 + I2C, or as SPI. SPI is not available unless D_SEL pin is set to low. See [Table 25](#) below.

Pin no.	D_SEL == 0	D_SEL == 1
42	SPI_SDO	UART1 TXD
43	SPI_SDI	UART1 RXD
44	SPI_CS_N	I2C SDA
45	SPI_CLK	I2C SCL

Table 25: D_SEL configuration

3.6.2 RESET_N

The ZED-F9K provides the ability to reset the receiver. The RESET_N pin is an input-only pin with an internal pull-up resistor. Driving RESET_N low for at least 100 ms will trigger a cold start.



The RESET_N pin will delete all information and trigger a cold start. It should only be used as a recovery option.

3.6.3 SAFEBOOT_N

The ZED-F9K provides a SAFEBOOT_N pin that is used to command the receiver safeboot mode.

If this pin is low at power up, the receiver starts in safeboot mode and GNSS operation is disabled.

The safeboot mode can be used to recover from situations where the flash content has become corrupted and needs to be restored.

In safeboot mode the receiver runs from a passive oscillator circuit with less accurate timing and hence the receiver is unable to communicate via USB.

In this mode UART1, I2C or SPI communication is possible. For communication via UART1 in safeboot mode, the host must send a training sequence (0x55 0x55 at 9600 baud) to the receiver in order to begin communication. After this the host must wait at least 2 ms before sending any data.

It is recommended to have the possibility to pull the SAFEBOOT_N pin low in the application. This can be provided using an externally connected test point or a host I/O port.

3.6.4 TIMEPULSE

The ZED-F9K high precision receiver provides a time pulse on the TIMEPULSE pin.

More information about the time pulse feature and its configuration can be found in the [Time pulse](#) section.

3.6.5 TX_READY

This feature enables each port to define a corresponding pin, which indicates if bytes are ready to be transmitted. A listener can wait on the TX-READY signal instead of polling the I2C or SPI interfaces. The CFG-TXREADY message lets you configure the polarity and the number of bytes in the buffer before the TX-READY signal goes active. By default, this feature is disabled. For USB, this feature is configurable but might not behave as described below due to a different internal transmission mechanism. If the number of pending bytes reaches the threshold configured for this port, the corresponding pin will become active (configurable active-low or active-high), and stay active until the last bytes have been transferred from software to hardware.



This is not necessarily equal to all bytes transmitted, i.e. after the pin has become inactive, up to 16 bytes might still need to be transferred to the host.

The TX_READY pin can be selected from all PIOs which are not in use (see UBX-MON-HW3 in the applicable interface description [2] for a list of the PIOs and their mapping). Each TX_READY pin is exclusively associated to one port and cannot be shared. If PIO is invalid or already in use, only the configuration for the specific TX_READY pin is ignored, the rest of the port configuration is applied if valid. The acknowledge message does not indicate if the TX-READY configuration is successfully set, it only indicates the successful configuration of the port. To validate successful configuration of the TX_READY pin, the port configuration should be read back and the settings of TX-READY feature verified (will be set to disabled/all zero if the settings are invalid).

The threshold when TX_READY is asserted should not be set above 2 kB as it is possible that the internal message buffer limit is reached before this. This results in the TX_READY pin never being set as the messages are discarded before the threshold is reached.

3.6.5.1 Extended TX timeout

If the host does not communicate over SPI or I2C for more than approximately 2 seconds, the device assumes that the host is no longer using this interface and no more packets are scheduled for this port. This mechanism can be changed by enabling "extended TX timeouts", in which case the receiver delays idling the port until the allocated and undelivered bytes for this port reach 4 kB. This feature is especially useful when using the TX-READY feature with a message output rate of less than once per second, and polling data only when data is available, determined by the TX_READY pin becoming active.

3.6.6 EXTINT

EXTINT is an external interrupt pin with fixed input voltage thresholds with respect to VCC. It can be used for functions such as accurate external frequency aiding and on/off control. The external frequency aiding can be used to calibrate the clock. This enables faster fix of satellite signals (UBX-MGA-INI-FREQ or UBX-MGA-INI-TIME_XXX) and can be used during normal operation or during the production test. Another possibility to use the extint feature is to wake up the receiver after putting it into backup mode; this can be set up with UBX-RXM-PMREQ. Leave open if unused, this function is disabled by default.

3.6.7 WT and DIR inputs

ZED-F9K pin 22 (WT) is available as a wheel tick input. Pin 23 (DIR) is available as a direction input (forward/reverse indication).

By default the wheel tick count is derived from the rising edges of the WT input.

The WT input may be configured to use both the rising and falling edges of the wheel tick signal. To use both edges, the wheel tick pulses shall have approximately 1:1 mark:space ratio regardless of speed. The minimum recommended pulse width is 10 us.

For optimal performance the wheel tick resolution should be less than 5 cm. The maximum supported wheel tick resolution is 40 cm.

The wheel tick input shall change frequency linearly with respect to the change in vehicle speed.

When the vehicle is stationary, there shall be no wheel tick pulses at the WT input. This is especially important at system shutdown and startup.

 Performance may be affected if there are wheel ticks on the WT pin while the vehicle is stationary.

The DIR input shall indicate whether the vehicle is moving forwards or backwards.

By default, the DIR pin polarity is automatically initialized once the vehicle has reached the required minimum speed (see [Accelerated initialization and calibration procedure](#) section). The DIR pin polarity can also be configured with the CFG-SFODO-DIR_PINPOL key.

 Incorrect operation may occur if WT input is used without a matching DIR input.

Alternatively, the vehicle WT (or speed) and DIR inputs can be provided via one of the communication interfaces with UBX-ESF-MEAS messages. In this use case, the WT pin can be configured as EXTINT to provide a time mark for the UBX-ESF-MEAS messages. The DIR pin can be left open.

 Do not exceed the maximum voltage of 3.6 V at the WT and DIR inputs.

 For more information, see the interface description [2].

3.6.8 RTK_STAT interface

The ZED-F9K provides an RTK_STAT pin that provides an indication of the RTK positioning status. It can be used to confirm if a valid stream of correction messages is being received. As valid correction messages we only consider the correction messages that are supported and used by the receiver.

In general, the RTK_STAT level can be interpreted as follows: Alternating (blinking) pin level, indicates that a valid stream of correction messages is being received and utilized but no RTK fixed mode has been achieved. An active low pin level indicates that RTK fixed mode has been achieved. Otherwise, the pin level is high.

The RTK_STAT pin status can be mapped to the `carrSoln` field of the UBX-NAV-PVT and interpreted as follows:

- An active low pin level indicates that RTK fixed mode has been achieved
- Alternating (blinking) pin level, indicates that a valid stream of correction messages is being received and utilized but no RTK fixed mode has been achieved
- An active high pin level indicates that no carrier phase solution is available

3.7 Antenna supervisor

An active antenna supervisor provides the means to check the antenna for open and short circuits and to shut off the antenna supply if a short circuit is detected. Once enabled, the active antenna supervisor produces status messages, reporting in NMEA and/or UBX protocol.

The antenna supervisor can be configured through the CFG-HW-ANT_* configuration items. The current configuration of the active antenna supervisor can also be checked by polling the related CFG-HW_ANT_* configuration items.

The current active antenna status can be determined by polling the UBX-MON-RF message. If an antenna is connected, the initial state after power-up is "Active Antenna OK" in the UBX-MON-RF message in the u-center "Message View".

An active antenna supervisor circuit is connected to the ANT_DET, ANT_OFF, ANT_SHORT_N pins. For an example the open circuit detection circuit using ANT_DET, "high" = Antenna detected (antenna consumes current); "low" = Antenna not detected (no current drawn).

The following schematic details the required circuit and the sections following it explain how to enable and monitor each feature:

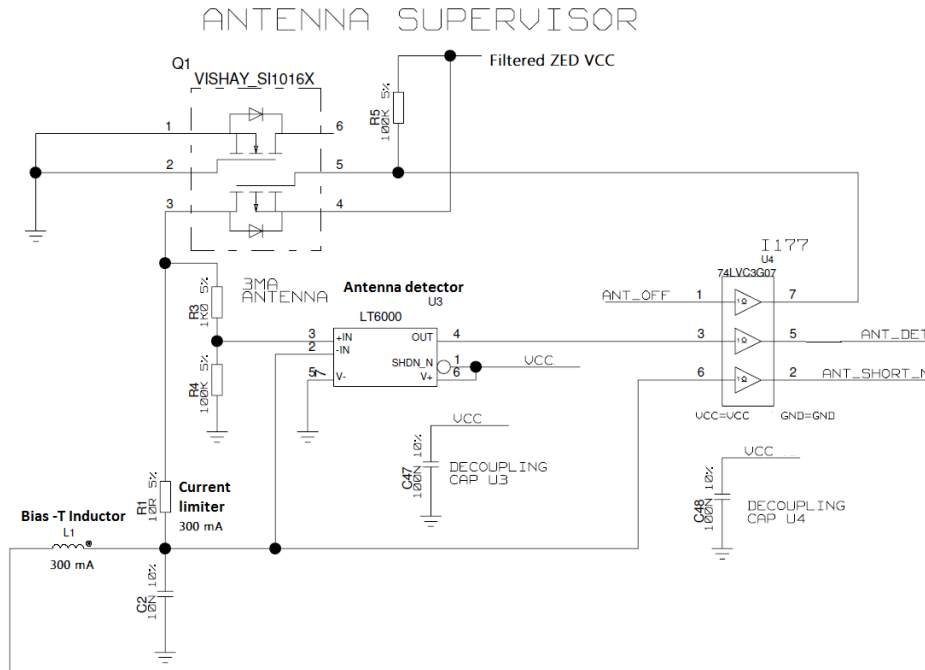

Figure 19: ZED-F9K antenna supervisor

- The bias-t inductor must be chosen for multi-band operation; a value of 47 nH \pm 5% is required for our recommended Murata part, with the current limited below its 300 mA rating. See [Antenna bias](#) section for additional information.
- Circuit shows buffer [U4]. Buffer is not strictly necessary when supplied from VCC. It is only required when supplying antenna voltage that is not obtained from or controlled by module VCC or VCC_RF .

Part	Recommendation	Comment
L1	Murata LQG15HS47NJ02/47N	300mA and >500 Ω at L-band frequencies
C2	Murata GRM033R71C103KE14	CAP CER X7R 0402 10N 10% 16V
	TYCO, 0.25PF, PESD0402-140 -55/+125C	ESD protection diode on RF trace

Table 26: Recommended components for antenna supervisor

3.7.1 Antenna voltage control - ANT_OFF

- Antenna status (as reported in UBX-MON-RF and UBX-INF-NOTICE messages) is not reported unless the antenna voltage control has been enabled.

Enable the antenna voltage control by setting the configuration item CFG-HW-ANT_CFG_VOLTCTRL to true (1).

Result:

- UBX-MON-RF in u-center "Message View": Antenna status = OK. Antenna power status = ON
- ANT_OFF pin = active high to turn antenna off therefore the pin is low to enable an external antenna.

Start-up message at power up if configuration stored:

```
$GNTXT,01,01,02,ANTSUPERV=AC *00
```

```
$GNTXT,01,01,02,ANTSTATUS=INIT*3B
```

```
$GNTXT,01,01,02,ANTSTATUS=OK*25
```

ANTSUPERV=AC indicates antenna control is activated

3.7.2 Antenna short detection - ANT_SHORT_N

Enable the antenna short detection by setting the configuration item CFG-HW-ANT_CFG_SHORTDET to true (1).

Result:

- UBX-MON-RF in u-center "Message View": Antenna status = OK. Antenna power status = ON
- ANT_OFF = active high to disable an external antenna therefore the pin is low to enable an external antenna.
- ANT_SHORT_N = active low to detect a short therefore the pin is high (PIO pull up enabled to be pulled low if shorted)

Start-up message at power up if configuration is stored:

```
$GNTXT,01,01,02,ANTSUPERV=AC SD *37
```

```
$GNTXT,01,01,02,ANTSTATUS=INIT*3B
```

```
$GNTXT,01,01,02,ANTSTATUS=OK*25
```

ANTSUPERV=AC SD (Antenna control and short detection activated)

Then if shorted (ANT_SHORT_N pulled low):

- UBX-MON-RF in u-center "Message View": Antenna status = SHORT. Antenna power status = ON (Antenna power control power down when short has not been enabled = off by default).

```
$GNTXT,01,01,02,ANTSTATUS=SHORT*73
```

- ANT_OFF = active high therefore still low (still enabled as auto power down is not enabled)



After a detected antenna short, the reported antenna status will keep on being reported as shorted. If the antenna short detection auto recovery is enabled, then the antenna status can recover after a timeout. To recover the antenna status immediately, a power cycle is required or configuring the antenna short detection functionality off and on.

3.7.3 Antenna short detection auto recovery

Enable the antenna short detection auto recovery by setting the configuration item CFG-HW-ANT_CFG_RECOVER to true (1).

Result:

- UBX-MON-RF in u-center "Message View": Antenna status = OK. Antenna power status = ON
- ANT_OFF = active high there for the PIO is low to enable an external antenna

- ANT_SHORT_N = high (PIO pull up enabled to be pulled low if shorted)

Start-up message at power up if configuration is stored:

```
$GNTXT,01,01,02,ANTSUPERV=AC SD PDoS SR*3E
```

```
$GNTXT,01,01,02,ANTSTATUS=INIT*3B
```

```
$GNTXT,01,01,02,ANTSTATUS=OK*25
```

ANTSUPERV=AC SD PDoS SR (indicates short circuit recovery added - SR)

Then if antenna is shorted (ANT_SHORT_N pulled low):

- \$GNTXT,01,01,02,ANTSTATUS=SHORT*73
- UBX-MON-RF in u-center "Message View": Antenna status = SHORT. Antenna power status = OFF
- ANT_OFF = high (to disable - active high)

After a time out period receiver will retest the short condition by enabling ANT_OFF = LOW

If a short is not present it will report antenna condition is OK:

```
$GNTXT,01,01,02,ANTSTATUS=OK*25
```

UBX-MON-RF in u-center "Message View": Antenna status = OK. Antenna power status = ON

3.7.4 Antenna open circuit detection - ANT_DETECT

Enable the antenna open circuit detection by setting the configuration item CFG-HW-ANT_CFG_OPENDET to true (1).

Result:

- UBX-MON-RF in u-center "Message View": Antenna status = OK. Antenna power status = ON
- ANT_OFF = active high therefore PIO is low to enable external antenna
- ANT_SHORT_N = active low therefore PIO is high (PIO pull up enabled to be pulled low if shorted)
- ANT_DETECT = active high therefore PIO is high (PIO pull up enabled to be pulled low if antenna not detected)

Start-up message at power up if configuration is stored:

```
$GNTXT,01,01,02,ANTSUPERV=AC SD OD PDoS SR*15
```

```
$GNTXT,01,01,02,ANTSTATUS=INIT*3B
```

```
$GNTXT,01,01,02,ANTSTATUS=OK*25
```

ANTSUPERV=AC SD OD PDoS SR (indicates open circuit detection added - OD)

Then if ANT_DETECT is pulled low to indicate no antenna:

```
$GNTXT,01,01,02,ANTSTATUS=OPEN*35
```

Then if ANT_DETECT is left floating or it is pulled high to indicate antenna connected:

```
$GNTXT,01,01,02,ANTSTATUS=OK*25
```

3.8 Multiple GNSS assistance (MGA)

The u-blox AssistNow services provide a proprietary implementation of an A-GNSS protocol compatible with u-blox GNSS receivers.

The MGA services consist of AssistNow Online and Offline variants delivered by HTTP or HTTPS protocol. AssistNow Online optionally provides immediate satellite ephemerides, health information and time aiding data suitable for GNSS receiver systems with direct internet access.

When a client device makes an AssistNow request, the service responds with the requested data using standard UBX protocol MGA messages. These messages are ready for direct transmission from the client to the receiver port without requiring any modification.

 The ZED-F9K supports AssistNow Online only.

3.8.1 Authorization

To use the AssistNow services, customers will need to obtain an authorization token from u-blox. Go to <https://www.u-blox.com/en/solution/services/assistnow> or contact your local technical support to get more information and to request access to the service.

3.8.2 Preserving MGA and operational data during power-off

The time-to-fix after a receiver power interruption is dependent on the amount of operational data available at startup. Satellite broadcast information plus an estimate of accurate time can be fetched from the AssistNow service. In addition, the following techniques can restore previously stored data prior to power down.

- **Battery-backed RAM:** The receiver operational state stored in this RAM can be maintained during power outages by connecting the V_BCKP pin to an independent supply, e.g a battery. This is a recommended method as it will maintain all MGA related information plus any user configuration, calibration data and an estimate of time via the Real Time Clock. See section [V_BCKP: Backup supply voltage](#) for more information.
- **Save-on-shutdown:** The receiver can be instructed to dump its current state to flash memory as part of the shutdown procedure; this data is then automatically retrieved when the receiver is restarted. For more information, see section [Save-on-shutdown feature](#) for more info. For information on the UBX-UPD-SOS messages consult the applicable interface description [2].
- **Advanced calibration handling:** The receiver can be instructed to dump its current state (UBX-MGA-SF and UBX-NAV-PVAT) to host as part of the shutdown procedure or during the drive; this data is then sent back to the receiver when the receiver is restarted. For more information, see section [Advanced calibration handling](#) for more info.
- **Database dump:** The receiver can be made to dump the state of its navigation database in the form of a sequence of UBX messages reported to the host; these messages can be stored by the host and then sent back to the receiver when it has been restarted. See the description of the UBX-MGA-DBD messages in the applicable interface description [2] for more information.

3.8.3 Save-on-shutdown feature

The save-on-shutdown feature (SOS) enables the u-blox receiver to store the contents of the battery-backed RAM to an external flash memory and restore it upon startup. This allows the u-blox receiver to preserve some of the features available only with a battery backup (preserving configuration, IMU calibration, and satellite orbit knowledge) without having a battery backup supply present. It does not, however, preserve any kind of time knowledge. Save-on-shutdown must be commanded by the host. The restoring of data on startup is automatically done if the corresponding data is present in the flash. Data expiration is not checked.

The following outlines the suggested shutdown procedure when using the save-on-shutdown feature:

- With the `UBX-CFG-RST` message, the host commands the u-blox receiver to stop, specifying reset mode `0x08` ("Controlled GNSS stop") and a BBR mask of `0` ("Hotstart").
- The host commands the saving of the contents of BBR to the flash memory using the `UBX-UPD-SOS-BACKUP` message.
- For a valid request the u-blox receiver reports on the success of the backup operation with a `UBX-UPD-SOS-ACK` message.
- The host powers off the u-blox receiver.

The startup procedure is as follows:

- The host powers on the u-blox receiver.
- The u-blox receiver detects the previously stored data in the flash. It restores the corresponding memory and reports the success of the operation with a `UBX-UPD-SOS-RESTORED` message on the port on which it had received the save command message (if the output protocol filter on that port allows it). It does not report anything if no stored data has been detected.
- Additionally the u-blox receiver outputs a `UBX-INF-NOTICE` and/or a `NMEA-TXT` message with the contents `RESTORED` in the boot screen (depends on the configuration of the port and information messages) upon success.
- Optionally the host can deliver coarse time assistance using `UBX-MGA-INI-TIME_UTC` for better startup performance.

Once the u-blox receiver has started up it is recommended to delete the stored data using a `UBX-UPD-SOS-CLEAR` message. The u-blox receiver responds with a `UBX-ACK-ACK` / `UBX-ACK-NAK` message.

 **CAUTION** Note that the save-on-shutdown feature works correctly only when the receiver has a valid time information when saving the `SOS-BACKUP`.

3.8.4 Advanced calibration handling

 Supported from firmware version LAP 1.30 onwards

The advanced calibration handling feature enables a host to poll and later send sensor initialization and calibration parameters. This information can be used to aid quick recovery of the receiver into sensor fusion or dead reckoning mode following a device reset or power down, especially when the battery backup is not provided or the save-on-shutdown feature is not used.

The following points outline the procedure when using the advanced calibration handling feature:

- Host should poll `UBX-MGA-SF` regularly (optimal time: every 5 min.) after the fusion mode has been achieved. The `UBX-ESF-STATUS.fusionMode` field should be set to `1:FUSION` before polling the `UBX-MGA-SF` message.
- Receiver replies with one or more `UBX-MGA-SF` messages. These messages should be stored at the host side.
- In the event of a reset or a power down, host can send the latest stored `UBX-MGA-SF` messages to the receiver. If there is a sudden power off, the user has to provide the last known position and the attitude solution to the receiver after the power cycle.
- The receiver attempts to reach sensor fusion mode using the data available in these messages.
- Depending on the availability of the GNSS signals the receiver can switch to either fusion mode (3D + DR) or dead reckoning mode (DR only). Host can poll `UBX-ESF-STATUS` to track the status of the sensors' calibration.

- UBXMGA-SF message is not output periodically, therefore it is required that the host polls the message regularly. This ensures that the host saves the latest parameters required for quick recovery into sensor fusion mode.
- Make sure to send the latest UBXMGA-SF messages to the receiver. Sending outdated messages could mean the receiver will take longer to reach sensor fusion mode.
- Only send the saved UBXMGA-SF messages to the same receiver they were obtained from.
- After the power cycle, the user needs to provide the last known position and the attitude via UBXMGA-INIT-POS and UBXMGA-INIT-ATT messages. The information can be taken from UBX-NAV-PVT and UBX-NAV-ATT or UBX-NAV-PVAT.
- Sending only the UBXMGA-SF message will be rejected by the receiver even if the receiver is in 3D-only mode.

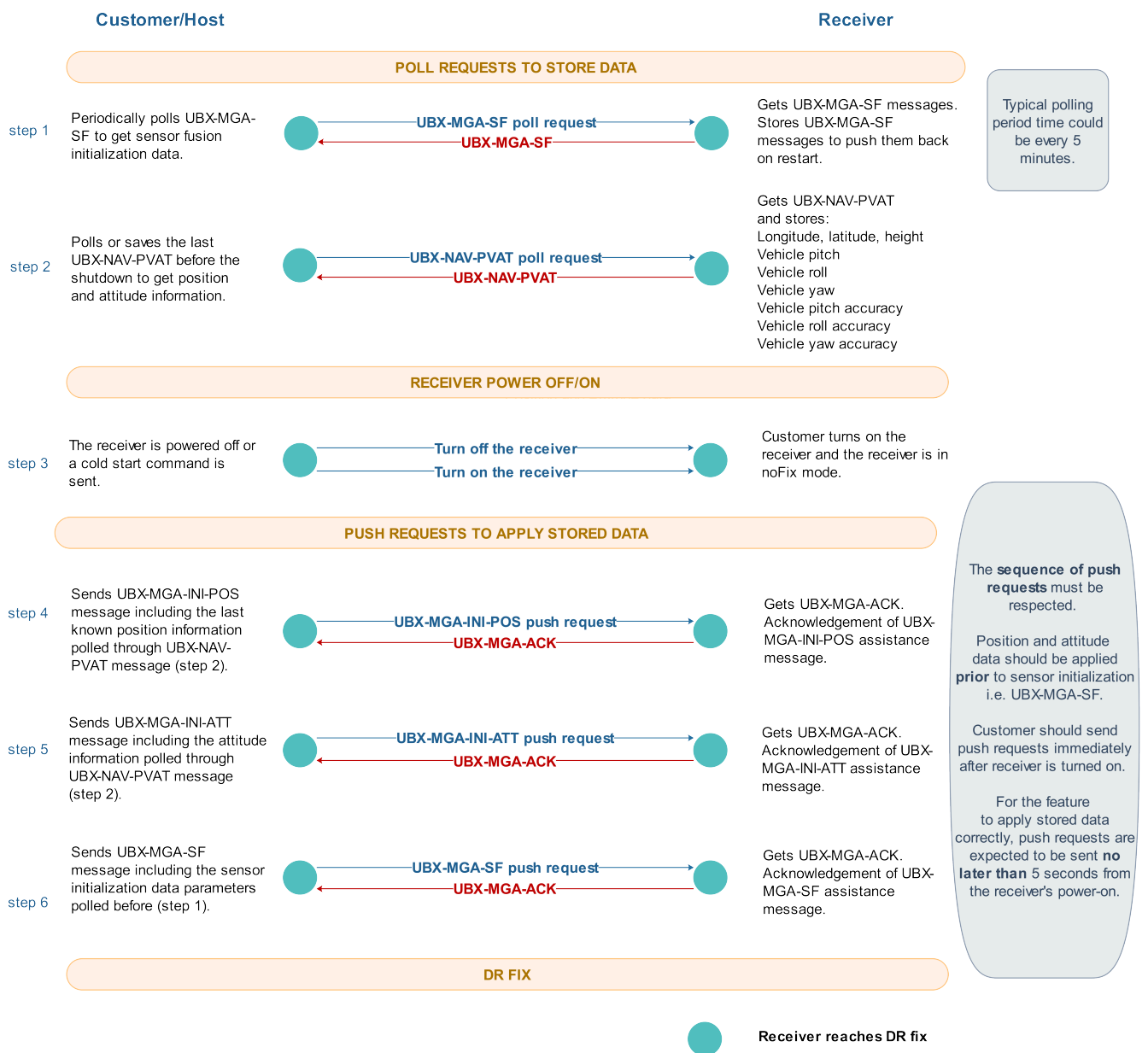

Figure 20: Advanced calibration handling operational steps

3.9 Clocks and time

This section introduces and explains the concepts of receiver clocks and time bases.

3.9.1 Receiver local time

The receiver is dependent on a local oscillator for both the operation of its radio parts and also for timing within its signal processing. No matter what nominal frequency the local oscillator has, u-blox receivers subdivide the oscillator signal to provide a 1-kHz reference clock signal, which is used to drive many of the receiver's processes. In particular, the measurement of satellite signals is arranged to be synchronized with the "ticking" of this 1-kHz clock signal.

When the receiver first starts, it has no information about how these clock ticks relate to other time systems; it can only count time in 1 millisecond steps. However, as the receiver derives information from the satellites it is tracking or from aiding messages, it estimates the time that each 1-kHz clock tick takes in the time base of the chosen GNSS system. This estimate of GNSS time based on the local 1-kHz clock is called receiver local time.

As receiver local time is a mapping of the local 1-kHz reference onto a GNSS time base, it may experience occasional discontinuities, especially when the receiver first starts up and the information it has about the time base is changing. Indeed, after a cold start, the receiver local time will initially indicate the length of time that the receiver has been running. However, when the receiver obtains some credible timing information from a satellite or an aiding message, it will jump to an estimate of GNSS time.

3.9.2 Navigation epochs

Each navigation solution is triggered by the tick of the 1-kHz clock nearest to the desired navigation solution time. This tick is referred to as a **navigation epoch**. If the navigation solution attempt is successful, one of the results is an accurate measurement of time in the time base of the chosen GNSS system, called **GNSS system time**. The difference between the calculated GNSS system time and receiver local time is called **clock bias** (and **clock drift** is the rate at which this bias is changing).

In practice the receiver's local oscillator will not be as stable as the atomic clocks to which GNSS systems are referenced and consequently clock bias will tend to accumulate. However, when selecting the next navigation epoch, the receiver will always try to use the 1-kHz clock tick which it estimates to be closest to the desired fix period as measured in GNSS system time. Consequently the number of 1-kHz clock ticks between fixes will occasionally vary. This means that when producing one fix per second, there will normally be 1000 clock ticks between fixes, but sometimes, to correct drift away from GNSS system time, there will be 999 or 1001.

The GNSS system time calculated in the navigation solution is always converted to a time in both the GPS and UTC time bases for output.

Clearly when the receiver has chosen to use the GPS time base for its GNSS system time, conversion to GPS time requires no work at all, but conversion to UTC requires knowledge of the number of leap seconds since GPS time started (and other minor correction terms). The relevant GPS-to-UTC conversion parameters are transmitted periodically (every 12.5 minutes) by GPS satellites, but can also be supplied to the receiver via the UBX-MGA-GPS-UTC aiding message. By contrast when the receiver has chosen to use the GLONASS time base as its GNSS system time, conversion to GPS time is more difficult as it requires knowledge of the difference between the two time bases, but as GLONASS time is closely linked to UTC, conversion to UTC is easier.

When insufficient information is available for the receiver to perform any of these time base conversions precisely, predefined default offsets are used. Consequently plausible times are nearly

always generated, but they may be wrong by a few seconds (especially shortly after receiver start). Depending on the configuration of the receiver, such "invalid" times may well be output, but with flags indicating their state (e.g. the "valid" flags in UBX-NAV-PVT).

 u-blox receivers employ multiple GNSS system times and/or receiver local times (in order to support multiple GNSS systems concurrently), so users should not use UBX messages reporting GNSS system time or receiver local time. It is recommended to use messages that report UTC time and other messages are retained only for backwards compatibility reasons.

3.9.3 iTOW timestamps

All the main UBX-NAV messages (and some other messages) contain an **iTOW** field which indicates the GPS time at which the navigation epoch occurred. Messages with the same iTOW value can be assumed to have come from the same navigation solution.

 With [Priority navigation mode](#) enabled, iTOW can be used as an epoch collector only for messages of the same group (e.g. priority navigation messages with the same iTOW value can be assumed to have come from the same navigation solution).

Note that iTOW values may not be valid (i.e. they may have been generated with insufficient conversion data) and therefore it is not recommended to use the iTOW field for any other purpose.

 The original designers of GPS chose to express time/date as an integer week number (starting with the first full week in January 1980) and a time of week (often abbreviated to TOW) expressed in seconds. Manipulating time/date in this form is far easier for digital systems than the more conventional year/month/day, hour/minute/second representation. Consequently, most GNSS receivers use this representation internally, only converting to a more conventional form at external interfaces. The iTOW field is the most obvious externally visible consequence of this internal representation.

If reliable absolute time information is required, users are recommended to use the UBX-NAV-PVT navigation solution message which also contains additional fields that indicate the validity (and accuracy in UBX-NAV-PVT) of the calculated times (see also the [GNSS times](#) section below for further messages containing time information).

3.9.4 GNSS times

Each GNSS has its own time reference for which detailed and reliable information is provided in the messages listed in the table below.

Time reference	Message
GPS time	UBX-NAV-TIMEGPS
BeiDou time	UBX-NAV-TIMEBDS
GLONASS time	UBX-NAV-TIMEGLO
Galileo time	UBX-NAV-TIMEGAL
QZSS time	UBX-NAV-TIMEQZSS
UTC time	UBX-NAV-TIMEUTC

Table 27: GNSS times

3.9.5 Time validity

Information about the validity of the time solution is given in the following form:

- **Time validity:** Information about time validity is provided in the `valid` flags (e.g. `validDate` and `validTime` flags in the UBX-NAV-PVT message). If these flags are set, the time is known and considered valid for use. These flags are shown in table GNSS times in section GNSS times above as well as in the UBX-NAV-PVT message.

- Time validity confirmation: Information about confirmed validity is provided in the `confirmedDate` and `confirmedTime` flags in the UBX-NAV-PVT message. If these flags are set, the time validity can be confirmed by using an additional independent source, meaning that the probability of the time to be correct is very high. Note that information about time validity confirmation is only available if the `confirmedAvai` bit in the UBX-NAV-PVT message is set.



`validDate` means that the receiver has knowledge of the current date. However, it must be noted that this date might be wrong for various reasons. Only when the `confirmedDate` flag is set, the probability of the incorrect date information drops significantly.



`validTime` means that the receiver has knowledge of the current time. However, it must be noted that this time might be wrong for various reasons. Only when the `confirmedTime` flag is set, the probability of incorrect time information drops significantly.



`fullyResolved` means that the UTC time is known without full seconds ambiguity. When deriving UTC time from GNSS time the number of leap seconds must be known, with the exception of GLONASS. It might take several minutes to obtain such information from the GNSS payload. When the one second ambiguity has not been resolved, the time accuracy is usually in the range of ~20s.

3.9.6 UTC representation

UTC time is used in many NMEA and UBX messages. In NMEA messages it is always reported rounded to the nearest hundredth of a second. Consequently, it is normally reported with two decimal places (e.g. 124923.52). Although compatibility mode (selected using CFG-NMEA-COMPAT) requires three decimal places, rounding to the nearest hundredth of a second remains, so the extra digit is always 0.

UTC time is also reported within some UBX messages, such as UBX-NAV-TIMEUTC and UBX-NAV-PVT. In these messages date and time are separated into seven distinct integer fields. Six of these (year, month, day, hour, min and sec) have fairly obvious meanings and are all guaranteed to match the corresponding values in NMEA messages generated by the same navigation epoch. This facilitates simple synchronization between associated UBX and NMEA messages.

The seventh field is called nano and it contains the number of nanoseconds by which the rest of the time and date fields need to be corrected to get the precise time. So, for example, the UTC time 12:49:23.521 would be reported as: hour: 12, min: 49, sec: 23, nano: 521000000.

It is however important to note that the first six fields are the result of rounding to the nearest hundredth of a second. Consequently the nano value can range from -5000000 (i.e. -5 ms) to +994999999 (i.e. nearly 995 ms).

When the nano field is negative, the number of seconds (and maybe minutes, hours, days, months or even years) will have been rounded up. Therefore, some or all of them must be adjusted in order to get the correct time and date. Thus in an extreme example, the UTC time 23:59:59.9993 on 31st December 2011 would be reported as: year: 2012, month: 1, day: 1, hour: 0, min: 0, sec: 0, nano: -700000.

Of course, if a resolution of one hundredth of a second is adequate, negative nano values can simply be rounded up to 0 and effectively ignored.

The UBX-NAV-TIMEUTC message gives information about UTC time reference clock.

The preferred variant of UTC time can be specified using CFG-NAVSPG-UTCSTANDARD configuration item.

3.9.7 Leap seconds

Occasionally it is decided (by one of the international time keeping bodies) that, due to the slightly uneven spin rate of the Earth, UTC has moved sufficiently out of alignment with mean solar time (i.e. the Sun no longer appears directly overhead at 0 longitude at midday). A "leap second" is therefore announced to bring UTC back into close alignment. This normally involves adding an extra second to the last minute of the year, but it can also happen on 30th June. When this happens UTC clocks are expected to go from 23:59:59 to 23:59:60 and only then on to 00:00:00.

It is also theoretically possible to have a negative leap second, in which case there will only be 59 seconds in a minute and 23:59:58 will be followed by 00:00:00.

u-blox receivers are designed to handle leap seconds in their UTC output and consequently users processing UTC times from either NMEA or UBX messages should be prepared to handle minutes that are either 59 or 61 seconds long.

Leap second information can be polled from the u-blox receiver with the message UBX-NAV-TIMELS.

3.9.8 Real-time clock

u-blox receivers contain circuitry to support a real-time clock, which (if correctly fitted and powered) keeps time while the receiver is otherwise powered off. When the receiver powers up, it attempts to use the real-time clock to initialize receiver local time and in most cases this leads to appreciably faster first fixes.

3.9.9 Date

All GNSS frequently transmit information about the current time within their data message. In most cases, this is a time of week (often abbreviated to TOW), which indicates the elapsed number of seconds since the start of the week (midnight Saturday/Sunday). In order to map this to a full date, it is necessary to know the week and so the GNSS also transmit a week number, typically every 30 seconds. Unfortunately the GPS L1C/A data message was designed in a way that only allows the bottom 10 bits of the week number to be transmitted. This is not sufficient to yield a completely unambiguous date as every 1024 weeks (a bit less than 20 years), the transmitted week number value "rolls over" back to zero. Consequently, GPS L1 receivers cannot tell the difference between, for example, 1980, 1999 or 2019 etc.

Fortunately, although BeiDou and Galileo have similar representations of time, they transmit sufficient bits for the week number to be unambiguous for the foreseeable future (the first ambiguity will be in 2078 for Galileo and not until 2163 for BeiDou). GLONASS has a different structure, based on a time of day, but again transmits sufficient information to avoid any ambiguity during the expected lifetime of the system (the first ambiguous date will be in 2124). Therefore, u-blox 9 receivers using Protocol Version 24 and above regard the date information transmitted by GLONASS, BeiDou and Galileo to be unambiguous and, where necessary, use this to resolve any ambiguity in the GPS date.



Customers attaching u-blox receivers to simulators should be aware that GPS time is referenced to 6th January 1980, GLONASS to 1st January 1996, Galileo to 22nd August 1999 and BeiDou to 1st January 2006; the receiver cannot be expected to work reliably with signals simulated before these dates.

3.9.9.1 GPS-only date resolution

In circumstances where only GPS L1C/A signals are available and for receivers with earlier firmware versions, the receiver establishes the date by assuming that all week numbers must be at least as large as a reference rollover week number. This reference rollover week number is hard-coded at compile time and is normally set a few weeks before the software is completed, but it can be overridden by CFG-NAVSPG-WKNROLLOVER configuration item to any value the user wishes.

The following example illustrates how this works: Assume that the reference rollover week number set in the firmware at compile time is 1524 (which corresponds to a week in calendar year 2009, but would be transmitted by the satellites as 500). In this case, if the receiver sees transmissions containing week numbers in the range of 500 ... 1023, these will be interpreted as week numbers 1524 ... 2047 (calendar year 2009 ... 2019), whereas transmissions with week numbers from 0 to 499 are interpreted as week numbers 2048 ... 2547 (calendar year 2019 ... 2028).



It is important to set the reference rollover week number appropriately when supplying u-blox receivers with simulated signals, especially when the scenarios are in the past.

3.9.10 Time pulse

3.9.10.1 Introduction

u-blox receivers include a time pulse function providing clock pulses with configurable duration and frequency. The time pulse function can be configured using the CFG-TP-* configuration group. The UBX-TIM-TP message provides time information for the next pulse and the time source.

Pulse Mode: Rising



Pulse Mode: Falling

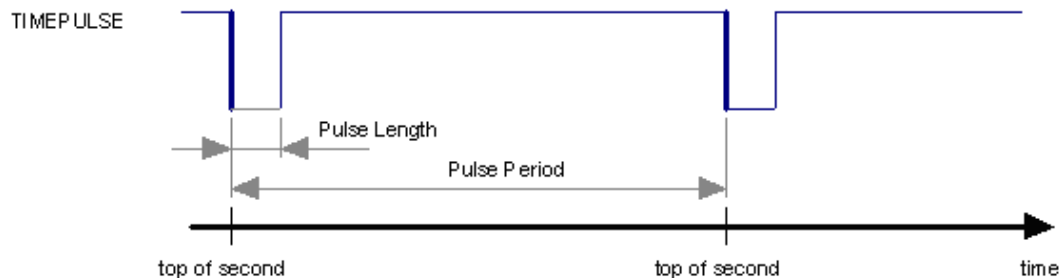

Figure 21: Time pulse

3.9.10.2 Recommendations

- The time pulse can be aligned to a wide variety of GNSS times or to variants of UTC derived from them (see the section on [time bases](#)). However, it is strongly recommended that the choice of time base is aligned with the available GNSS signals (so to produce GPS time or UTC(USNO), ensure GPS signals are available, and for GLONASS time or UTC(SU) ensure the presence GLONASS signals). This will involve coordinating the setting of CFG-SIGNAL-* configuration group with the choice of time pulse time base.
- When using time pulse for timing applications requiring absolute time accuracy, e.g. with requirements specifying offset to UTC, it is recommended to calibrate the user's full setup for TP output against a reference timing source. To achieve best absolute and consistent accuracy (e.g. for mass deployment), it is recommended that the user should calibrate each single setup

and calibrate under different GNSS modes and different temperatures which are applicable to the user's application and operating requirements. The user should take the calibrated values and configure the compensation accordingly (see the section on [Time pulse configuration](#))

- To get the best timing accuracy with the antenna, a fixed and *accurate* position is needed.
- If relative time accuracy between multiple receivers is required, do not mix receivers of different product families. If this is required, the receivers must be calibrated accordingly, by setting cable delay and user delay.
- The recommended configuration when using the UBX-TIM-TP message is to set both the measurement rate (CFG-RATE-MEAS) and the time pulse frequency (CFG-TP-*) to 1 Hz.



Since the rate of UBX-TIM-TP is bound to 1 Hz, more than one UBX-TIM-TP message can appear between two pulses if the time pulse frequency is set larger than 1 Hz. In this case all UBX-TIM-TP messages in between time pulses T1 and T2 belong to T2 and the last UBX-TIM-TP before T2 reports the most accurate quantization error. In general, if the time pulse rate is not configured to 1 Hz, there will not be a single UBX-TIM-TP message for each time pulse.

The sequential order of the signal present at the TIMEPULSE pin and the respective output message for the simple case of 1 pulse per second (1PPS) is shown in the following figure.

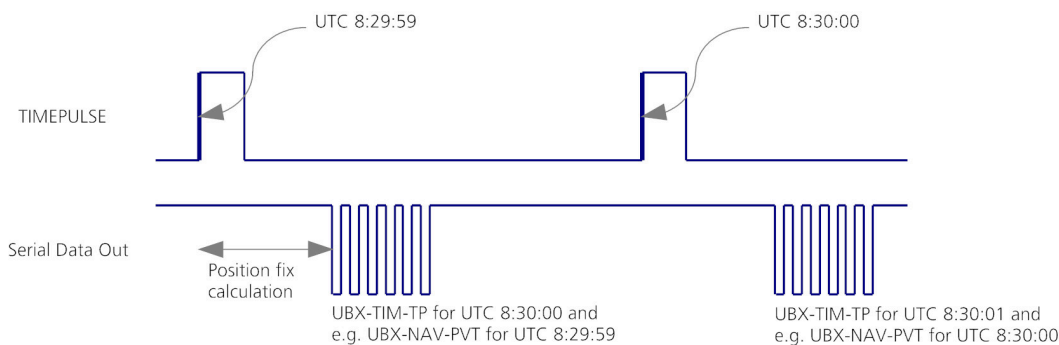

Figure 22: Time pulse and TIM-TP

3.9.10.3 GNSS time bases

GNSS receivers must handle a variety of different time bases as each GNSS has its own reference system time. What is more, although each GNSS provides a model for converting their system time into UTC, they all support a slightly different variant of UTC. So, for example, GPS supports a variant of UTC as defined by the US National Observatory, while BeiDou uses UTC from the National Time Service Center, China (NTSC). While the different UTC variants are normally closely aligned, they can differ by as much as a few hundreds of nanoseconds.

Although u-blox receivers can combine a variety of different GNSS times internally, the user must choose a single type of GNSS time and, separately, a single type of UTC for input (on EXTINT pins) and output (via the TIMEPULSE pin) and the parameters reported in corresponding messages.

The CFG-TP-TIMEGRID_TP* configuration item allows the user to choose between any of the supported GNSS (GPS, GLONASS, BeiDou, etc.) time bases and UTC. Also, the CFG-NAVSPG-UTCSTANDARD configuration item allows the user to select which variant of UTC the receiver should use. This includes an "automatic" option which causes the receiver to select an appropriate UTC version itself, based on the GNSS configuration, using, in order of preference, USNO if GPS is enabled, SU if GLONASS is enabled, NTSC if BeiDou is enabled, European if Galileo is enabled, finally, NPLI if NAVIC is enabled.

The receiver will assume that an input time pulse uses the same GNSS time base as specified for the time pulse output. So if the user selects GLONASS time for time pulse output, any time pulse input

must also be aligned to GLONASS time (or to the separately chosen variant of UTC). Where UTC is selected for time pulse output, any GNSS time pulse input will be assumed to be aligned to GPS time.



u-blox receivers allow users to independently choose GNSS signals used in the receiver (using CFG-SIGNAL-*) and the input/output time base (using CFG-TP-*). For example it is possible to instruct the receiver to use GPS and GLONASS satellite signals to generate BeiDou time. This practice will compromise time pulse accuracy if the receiver cannot measure the timing difference between the constellations directly and is therefore not recommended.



The information that allows GNSS times to be converted to the associated UTC times is only transmitted by the GNSS at relatively infrequent periods. For example GPS transmits UTC(USNO) information only once every 12.5 minutes. Therefore, if a time pulse is configured to use a variant of UTC time, after a cold start, substantial delays before the receiver has sufficient information to start outputting the time pulse can be expected.

3.9.10.4 Time pulse configuration

u-blox ZED-F9K receivers provide a time pulse (TIMEPULSE) signal with a configurable pulse period, length and polarity (rising or falling edge).

It is possible to define different signal behavior (i.e. output frequency and pulse length) depending on whether or not the receiver is locked to a reliable time source. Time pulse signal can be configured using the configuration group CFG-TP-*.

3.9.10.5 Configuring time pulse with CFG-TP-*

The configuration group CFG-TP-* can be used to change the time pulse settings, and includes the following parameters defining the pulse:

- **timepulse enable** - If this item is set, the time pulse is active.
- **frequency/period type** - Determines whether the time pulse is interpreted as frequency or period.
- **length/ratio type** - Determines whether the time pulse length is interpreted as length [us] or pulse ratio [%].
- **antenna cable delay** - Signal delay owing to RF components (e.g. antenna, cable, and splitter etc.) before the receiver input. This delay parameter affects the receiver calculation of GNSS time and it is used to compensate for the signal transit time prior to the receiver and any uncompensated delay from the receiver; a positive value compensates this delay, i.e. advances the time pulse
- **pulse frequency/period** - Frequency or pulse time period when locked mode is not configured or active.
- **pulse frequency/period lock** - Frequency or pulse time period, as soon as the receiver has calculated a valid time from a received signal. Only used if the corresponding item is set to use another setting in locked mode.
- **pulse length/ratio** - Length or duty cycle of the generated pulse, either specifies a time or ratio for the pulse to be on/off.
- **pulse length/ratio lock** - Length or duty cycle of the generated pulse, as soon as the receiver has calculated a valid time from a received signal. Only used if the corresponding item is set to use another setting in locked mode.
- **user delay** - A time offset of the TP output for adjustment in a user application. It adjusts the time pulse position only with respect to GNSS time. Configuring a positive value will add a delay, i.e. retard the pulse with respect to GNSS time. Conversely, a negative value will advance the pulse. This configuration is available for all supported TP outputs.
- **lock to GNSS freq** - If this item is set, uses the frequency gained from the GNSS signal information rather than the local oscillator's frequency.

- **locked other setting** - If this item is set, the alternative setting will be used as soon as the receiver can calculate a valid time. This mode can be used, for example, to disable time pulse if the time is not locked, or to indicate a lock with different duty cycles.
- **align to TOW** - If this item is set, pulses are aligned to the top of a second.
- **polarity** - If set, the first edge of the pulse is a rising edge (pulse polarity: rising).
- **grid UTC/GNSS** - Selection between UTC (0), GPS (1), GLONASS (2), BeiDou (3) and (4) Galileo timegrid. Also affects the time output by UBX-TIM-TP message.



The maximum pulse length cannot exceed the pulse period.



Time pulse settings shall be chosen in such a way that neither the high nor the low period of the output is less than 50 ns (except when disabling it completely), otherwise pulses can be lost.

3.9.10.5.1 Example

The example below shows the 1PPS TIMEPULSE signal generated on the time pulse output according to the specific parameters of the CFG-TP-* configuration group:

- **CFG-TP-TP1_ENA** = 1
- **CFG-TP-PERIOD_TP1** = 1 000 000 μ s
- **CFG-TP-LEN_TP1** = 100 000 μ s
- **CFG-TP-TIMEGRID_TP1** = 1 (GPS)
- **CFG-TP-PULSE_LENGTH_DEF** = 0 (Period)
- **CFG-TP-ALIGN_TO_TOW_TP1** = 1
- **CFG-TP-USE_LOCKED_TP1** = 1
- **CFG-TP-POL_TP1** = 1
- **CFG-TP-PERIOD_LOCK_TP1** = 1 000 000 μ s
- **CFG-TP-LEN_LOCK_TP1** = 100 000 μ s

The 1 Hz output is maintained whether or not the receiver is locked to GPS time. The alignment to TOW can only be maintained when GPS time is locked.

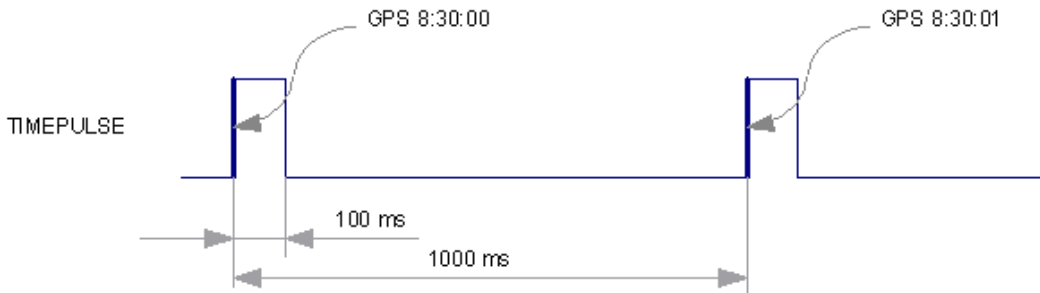

Figure 23: Time pulse signal with the example parameters

3.9.11 Time mark

The receiver can be used to provide an accurate measurement of the time at which a pulse was detected on the external interrupt pin. The reference time can be chosen by setting the time source parameter to UTC, GPS, GLONASS, BeiDou, Galileo or local time in the CFG-TP-* configuration group. The UTC standard can be set in the CFG-NAVSPG-* configuration group. The delay figures defined with CFG-TP-* are also applied to the results output in the UBX-TIM-TM2 message.

A UBX-TIM-TM2 message is output at the next epoch if

- The UBX-TIM-TM2 message is enabled, and
- A rising or falling edge was triggered since last epoch on one of the EXTINT channels.

The UBX-TIM-TM2 messages includes the time of the last time mark, new rising/falling edge indicator, time source, validity, number of marks and an accuracy estimate.

☞ Only the last rising and falling edge detected between two epochs is reported since the output rate of the UBX-TIM-TM2 message corresponds to the measurement rate configured with CFG-RATE-MEAS (see [Figure 24](#) below).

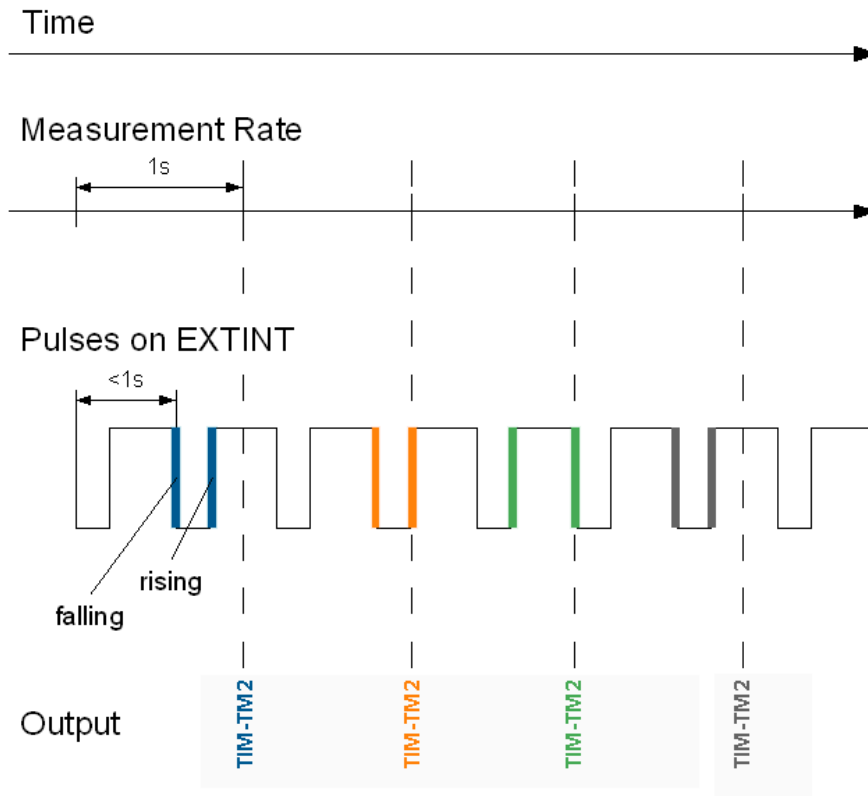

Figure 24: Time mark

3.10 Security

The security concept of ZED-F9K covers:

- the security of the receiver
- communication between the receiver and the GNSS satellites

Some receiver security functions monitor and detect threats and report them to the host system. Other security functions mitigate threats and allow the receiver to operate normally.

The table below gives an overview about possible threats and which functionality is available to detect and/or mitigate it.

Threat	u-blox solution
Over air signal security	Spoofing detection and monitoring Jamming interference detection and monitoring
GNSS receiver security	Secure boot

Threat	u-blox solution
	Secure firmware update
	Receiver configuration lock

Table 28: u-blox security options

3.10.1 Spoofing detection and monitoring

Spoofing is the process where a counterfeit GNSS signal is transmitted locally to deceive the receiver/user and produce an erroneous position fix and/or time solution.

The detection algorithm monitors GNSS signals for implausible changes or inconsistencies. These are evaluated with regards to spoofing.

A detection is successful when a signal is observed to transition from an initially genuine one to a spoofed version. Hence detection is not possible if the receiver is started under spoofing conditions. The detection algorithms also rely on availability of signals from multiple GNSS constellations to improve the spoofing detection capabilities.

Furthermore, with LAP 1.30, the receiver supports sensor-based spoofing detection. If the sensors are initialized, the receiver detects the presence of spoofing by comparing GNSS information against the sensor data.

-  If the sensors are not calibrated and spoofing is detected, the spoofing detection flag may not be sustained for a long period of time.

3.10.2 Jamming interference detection and monitoring

GNSS receivers can be jammed intentionally and/or unintentionally which can degrade the quality of GNSS signals and receiver performance. All u-blox receivers have the capability to detect and monitor jamming and report it to the user. This monitoring function is always enabled to inform the user about interference in the GNSS RF bands.

3.10.3 Spoofing and jamming indication

The UBX-SEC-SIG message provides a direct method for monitoring the current security status at each navigation epoch to alert the host about potential jamming or spoofing events.

The UBX-SEC-SIGLOG message provides a log of past events triggered by jamming or spoofing detection.

Each event is a combination of a detection type and an event type, where the event type 'indication started' and 'indication stopped' and also the event type 'indication triggered' and 'indication timeout' form a pair.

A maximum of 16 events are logged and new events take precedence over past events in the log. Power cycles and restarts of the receiver reset the log, deleting its content.

See the applicable interface description [2].

3.10.4 GNSS receiver security

3.10.4.1 Secure boot

The ZED-F9K boots only with firmware images that are signed by u-blox. This prevents the execution of non-genuine firmware images on the receiver.

3.10.4.2 Secure firmware update

The firmware image is signed by u-blox. The ZED-F9K verifies the signature during the firmware update.

3.10.4.3 Receiver configuration lock

The receiver configuration lock feature ensures that no configuration changes are possible once the feature is enabled. The configuration lock is enabled by setting the configuration item CFG-SEC-CFG_LOCK to "true".

The configuration lock can be applied to different configuration layers including the RAM, BBR, and flash memory. At startup, the receiver constructs the configuration database from different configuration layers and maintains it in the run-time RAM memory. When the configuration lock is set in the run-time RAM, the receiver configuration cannot be changed on any configuration layer.



For more information on the configuration layers including the order of priority they are applied in, see the applicable interface description [2].

The configuration lock set on a configuration layer in volatile memory (RAM, BBR) is removed when the memory is cleared. However, the configuration lock set in non-volatile memory (flash memory) is permanent apart from one exception: during firmware upload to flash memory, the flash is erased during the process causing the configuration lock to be cleared. Refer to [Firmware upload](#) for more information on firmware update.

To test the lock functionality, set it on the RAM configuration layer. After a power cycle, the information on RAM layer is cleared and the lock is no longer set.



It is recommended to apply the configuration lock on the same layer the configuration is stored.

An example of use case is that the host application locks the receiver configuration. A user communicating with the ZED-F9K through any of the available interfaces can poll, enable or send messages, but cannot change the configuration by sending UBX configuration messages.

3.11 u-blox protocol feature descriptions

3.11.1 Broadcast navigation data

This section describes the data reported via UBX-RXM-SFRBX.

UBX-RXM-SFRBX reports the broadcast navigation data message the receiver has collected from each tracked signal. When enabled, a separate message is generated each time the receiver decodes a complete subframe of data from a tracked signal. The data bits are reported as received, including preambles and error checking bits as appropriate. However, because there is considerable variation in the data structure of the different GNSS signals, the form of the reported data also varies. This document uses the term "subframe", but other GNSS data structures might use different terms, for example, GLONASS uses "strings" and Galileo uses "pages".

3.11.1.1 Parsing navigation data subframes

Each UBX-RXM-SFRBX message contains a subframe of data bits appropriate for the relevant GNSS, delivered in a number of 32-bit words, as indicated by numWords field.

Due to the variation in data structure between different GNSS, the most important step in parsing a UBX-RXM-SFRBX message is to identify the form of the data. This should be done by reading the gnssId field, which indicates which GNSS the data was decoded from. In almost all cases, this is sufficient to indicate the structure. Because of this, the following sections are organized by GNSS.

However, in some cases the identity of the GNSS is not sufficient, and this is described, where appropriate, in the following sections.

In most cases, the data does not map perfectly into a number of 32-bit words and, consequently, some of the words reported in UBX-RXM-SFRBX messages contain fields marked as "Pad". These fields should be ignored and no assumption should be made about their contents.

UBX-RXM-SFRBX messages are only generated when complete subframes are detected by the receiver and all appropriate parity checks have passed.

Where the parity checking algorithm requires data to be inverted before it is decoded (e.g. GPS L1C/A), the receiver carries this out before the message output. Therefore, users can process data directly and do not need to worry about repeating any parity processing.

The meaning of the content of each subframe depends on the sending GNSS and is described in the relevant interface control documents (ICD).

3.11.1.2 GPS

The data message structure in the GPS L1C/A (LNAV) and L2C/L5 (CNAV) signals is different and thus the UBX-RXM-SFRBX message structure differs as well. For the GPS L1C/A and L2C/L5 signals it is as follows:

3.11.1.2.1 GPS L1C/A

For GPS L1C/A signals, there is a fairly straightforward mapping between the reported subframe and the structure of subframe and words described in the GPS ICD. Each subframe comprises ten data words, which are reported in the same order they are received.

Each word is arranged as follows:

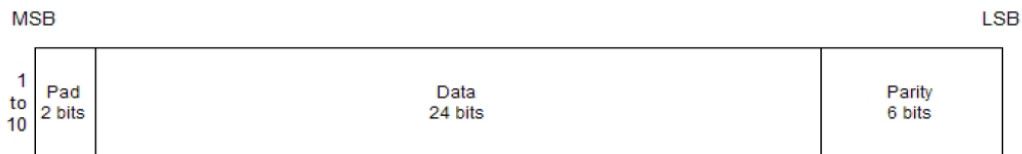

Figure 25: GPS L1C/A subframe word

3.11.1.2.2 GPS L2C

For GPS L2C signals each reported subframe contains the CNAV message as described in the GPS ICD. The ten words are arranged as follows:

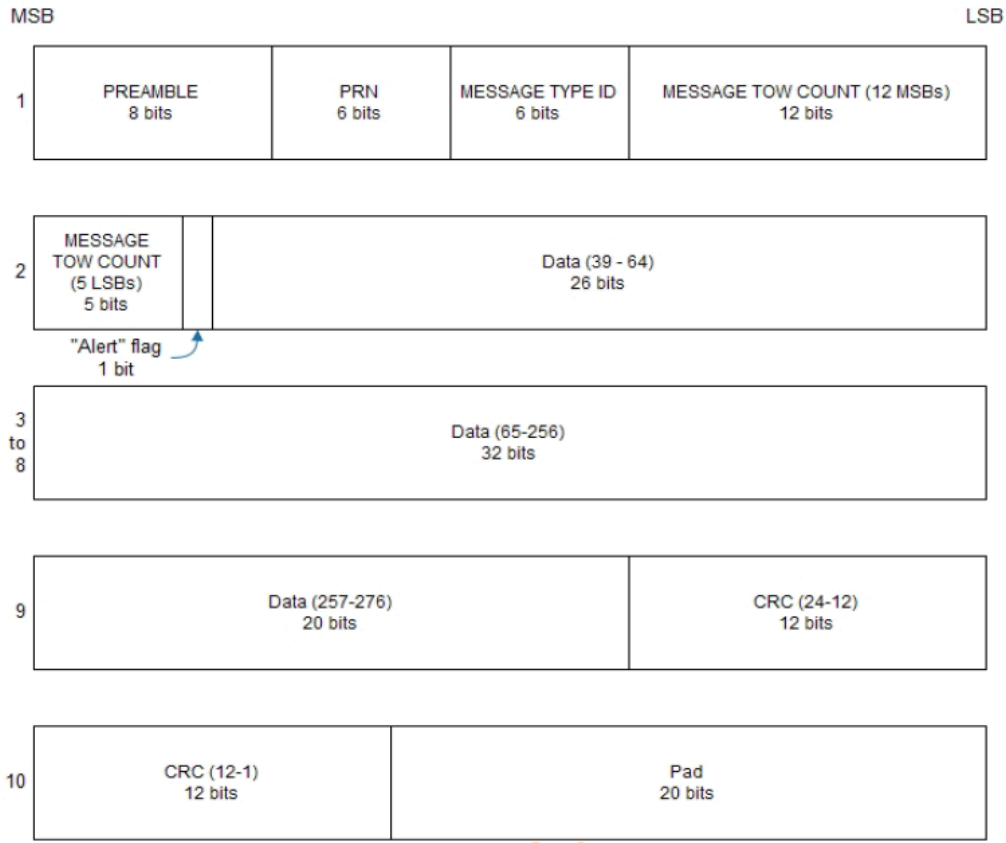

Figure 26: GPS L2C subframe words

3.11.1.2.3 GPS L5

Supported from firmware version LAP 1.30 onwards

For GPS L5 signals each reported subframe contains the CNAV message as described in the GPS ICD. The ten words are arranged as follows:

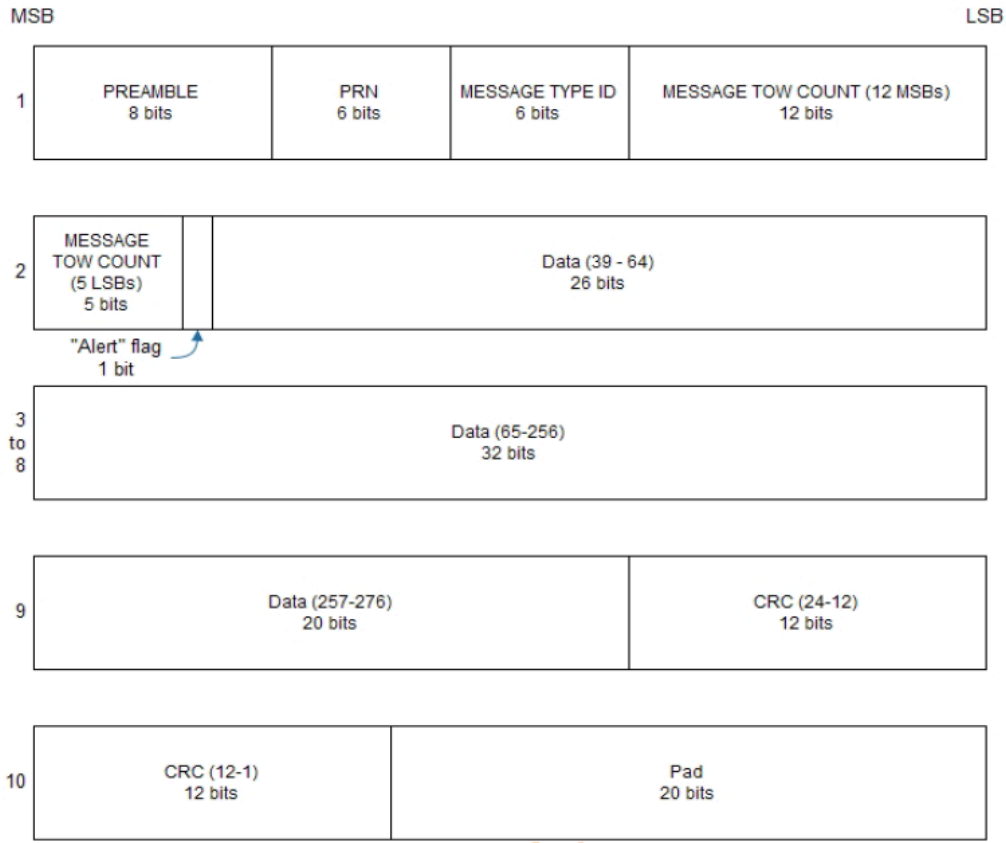

Figure 27: GPS L5 subframe words

3.11.1.3 GLONASS

For GLONASS L1OF signal, the UBX-RXM-SFRBX message contains a string content within the frame structure as described in the GLONASS ICD. This string comprises 85 data bits which are reported over three 32-bit words in the message. Data bits 1 to 8 are always a hamming code, while bits 81 to 84 are a string number and bit 85 is the idle chip, which should always have a value of zero. The meaning of other bits varies with string and frame number.

The fourth and final 32-bit word in the UBX-RXM-SFRBX message contains frame and superframe numbers (where available). These values are not actually transmitted by the satellites, but are deduced by the receiver and are included to aid decoding of the transmitted data. However, the receiver does not always know these values, in which case a value of zero is reported.

The four words are arranged as follows:

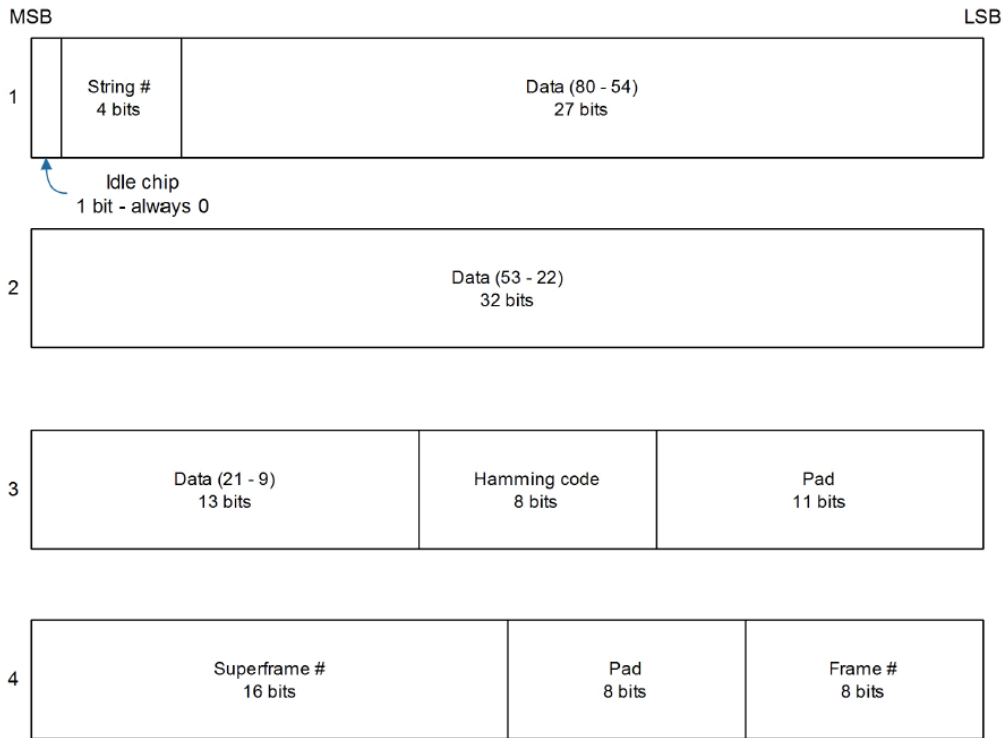

Figure 28: GLONASS navigation message data

In some circumstances, (especially on startup) the receiver may be able to decode data from a GLONASS satellite before it can identify it. When this occurs UBX-RXM-SFRBX messages will be issued with an svld of 255 to indicate "unknown".

3.11.1.4 BeiDou

For BeiDou signals there is a fairly straightforward mapping between the reported subframe and the structure of subframe and words described in the BeiDou ICD. Each subframe comprises ten data words, which are reported in the same order they are received.

Each word is arranged as follows:

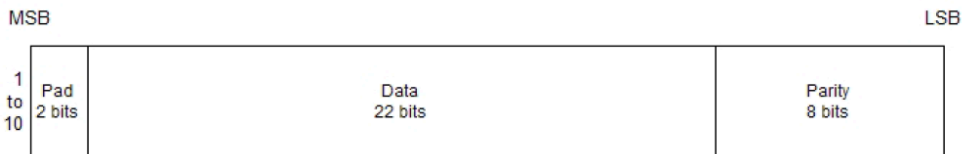

Figure 29: BeiDou subframe word

Note that as the BeiDou data words only comprise 30 bits, the 2 most significant bits in each word reported by UBX-RXM-SFRBX are padding and should be ignored.

3.11.1.5 Galileo

The Galileo E1-B and E5b in-phase signals transmit the I/NAV data message but in different configurations to enhance download time for dual frequency receivers. The UBX-RXM-SFRBX structure for the I/NAV message is shown below.

3.11.1.5.1 Galileo E1-B

For the Galileo E1-B signal, each reported subframe contains a pair of I/NAV pages as described in the Galileo ICD. Galileo pages can either be "Nominal" or "Alert" pages. For Galileo "Nominal" pages the eight words are arranged as follows:

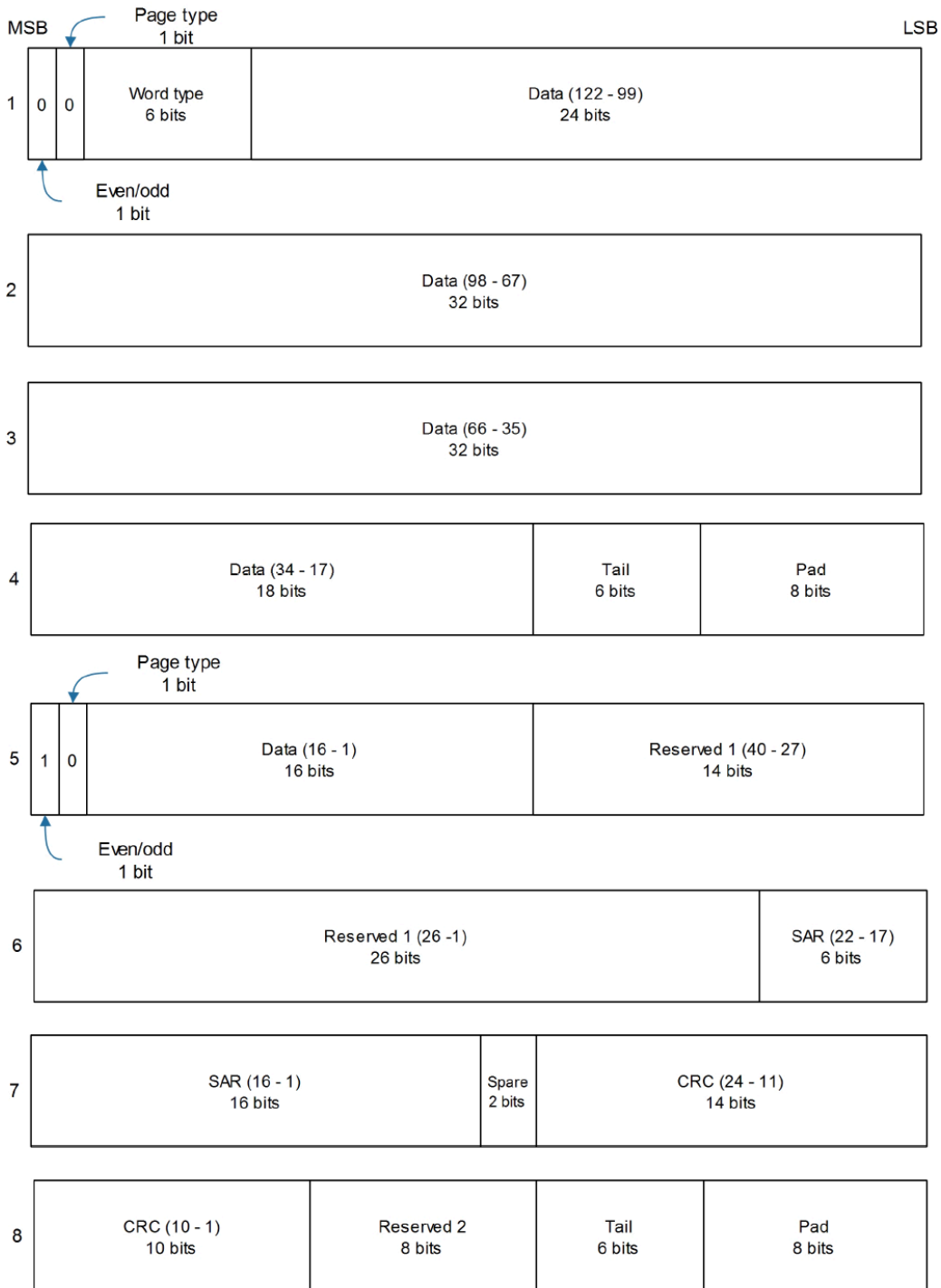

Figure 30: Galileo E1-B subframe words

Alert pages are reported in very similar manner, but the page type bits will have value 1 and the structure of the eight words will be slightly different (as indicated by the Galileo ICD).

3.11.1.5.2 Galileo E5b

For the Galileo E5b in-phase signal data component, each reported subframe contains a pair of I/NAV pages as described in the Galileo ICD. Galileo pages can either be "Nominal" or "Alert" pages. For Nominal pages the eight words are arranged as follows:

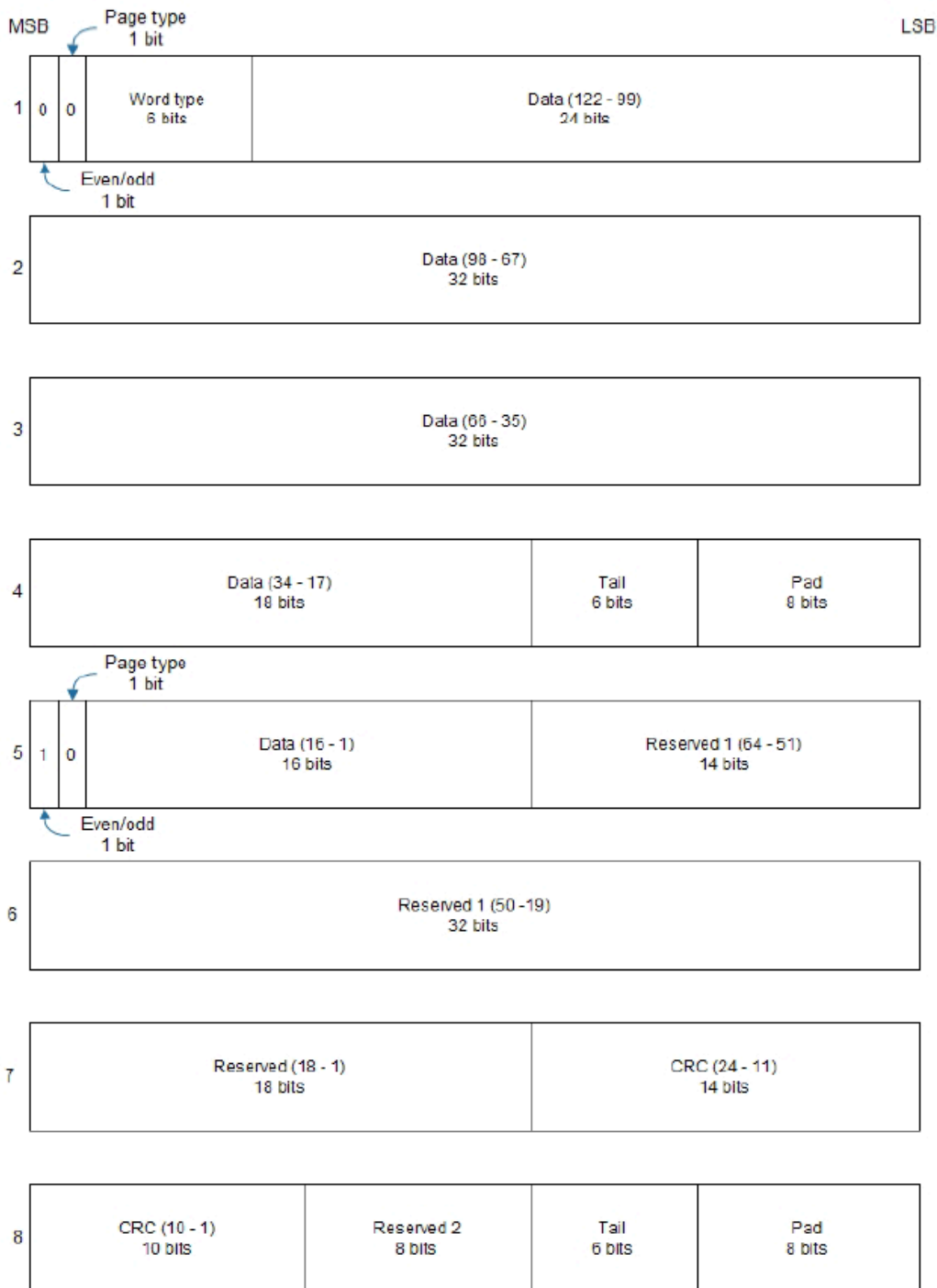

Figure 31: Galileo E5b subframe words

3.11.1.5.3 Galileo E5a

Supported from firmware version LAP 1.30 onwards

For the Galileo E5a in-phase signal data component, each reported subframe contains a number of F/NAV pages as described in the Galileo ICD. For each page the eight words are arranged as follows:

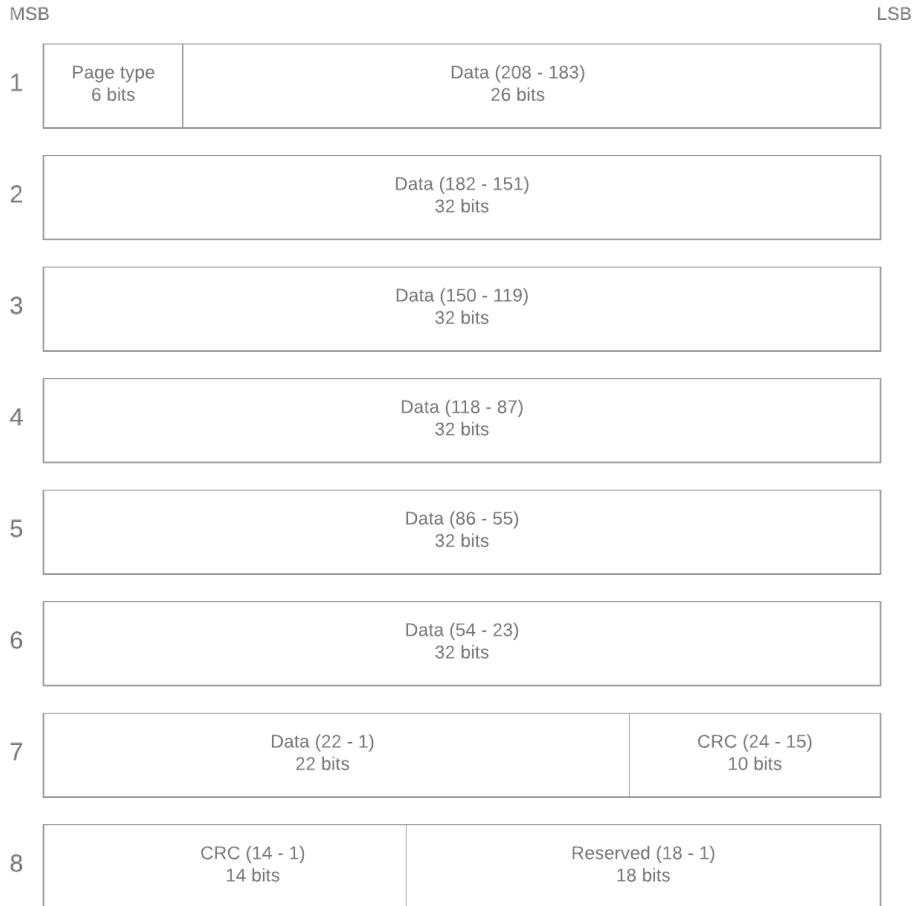

Figure 32: Galileo E5a subframe words

3.11.1.6 SBAS

For SBAS (L1C/A) signals each reported subframe contains eight 32-bit data words to deliver the 250 bits transmitted in each SBAS data block.

The eight words are arranged as follows:

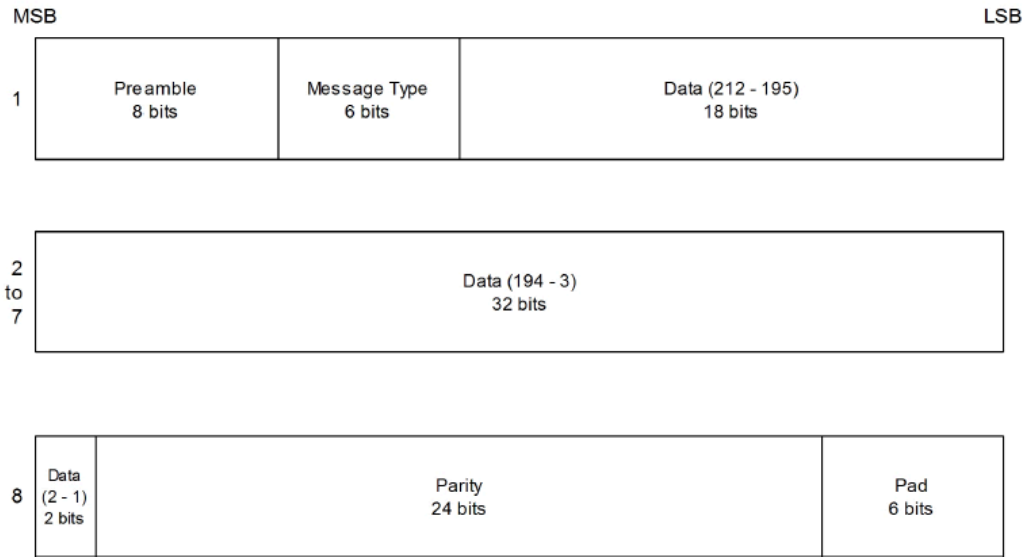

Figure 33: SBAS subframe words

3.11.1.7 QZSS

The structure of the data delivered by QZSS L1C/A signals is effectively identical to that of GPS (L1C/A). Similarly the structure of the data delivered by the QZSS L2C signal is effectively identical to that of GPS (L2C).

3.11.1.8 Summary

The following table gives a summary of the different data message formats reported by the UBX-RXM-SFRBX message:

GNSS	Signal	gnssId	sigId	numWords	period
GPS	L1C/A	0	0	10	6s
GPS	L2CL	0	3	10	12s
GPS	L2CM	0	4	10	12s
GPS	L5 I	0	6	10	6s
SBAS	L1C/A	1	0	9	1s
Galileo	E1 B	2	1	8	2s
Galileo	E5b I	2	5	8	2s
Galileo	E5a I	2	3	8	10s
BeiDou	B1I D1	3	0	10	6s
BeiDou	B1I D2	3	1	10	0.6s
BeiDou	B2I D1	3	2	10	6s
BeiDou	B2I D2	3	3	10	0.6s
BeiDou	B2a	3	7	9	3s
QZSS	L1C/A	5	0	10	6s
QZSS	L2CM	5	4	10	12s
QZSS	L2CL	5	5	10	12s
QZSS	L5 I	5	8	10	6s
GLONASS	L1OF	6	0	3	2s

GNSS	Signal	gnssId	sigId	numWords	period
GLONASS	L2OF	6	2	3	2s

Table 29: Data message formats reported by UBX-RXM-SFRBX

3.12 Forcing a receiver reset

Typically, in GNSS receivers, a distinction is made between cold, warm, and hot start, depending on the type of valid information the receiver has at the time of the restart.

- **Cold start:** In cold start mode, the receiver has no information from the last position (e.g. time, velocity, frequency etc.) at startup. Therefore, the receiver must search the full time and frequency space, and all possible satellite numbers. If a satellite signal is found, it is tracked to decode the ephemeris (18-36 seconds under strong signal conditions), whereas the other channels continue to search satellites. Once there is a sufficient number of satellites with valid ephemeris, the receiver can calculate position and velocity data. Other GNSS receiver manufacturers call this startup mode **Factory startup**.
- **Warm start:** In warm start mode, the receiver has approximate information for time, position, and coarse satellite position data (Almanac). In this mode, after power-up, the receiver normally needs to download ephemeris before it can calculate position and velocity data. As the ephemeris data usually is outdated after 4 hours, the receiver will typically start with a warm start if it has been powered down for more than 4 hours. In this scenario, several augmentations are possible. See [Multiple GNSS assistance](#).
- **Hot start:** In hot start mode, the receiver was powered down only for a short time (4 hours or less), so that its ephemeris is still valid. Since the receiver does not need to download ephemeris again, this is the fastest startup method.

Using the UBX-CFG-RST message, you can force the receiver to reset and clear data, in order to see the effects of maintaining/losing such data between restarts. For this, the UBX-CFG-RST message offers the `navBbrMask` field, where hot, warm and cold starts can be initiated, and also other combinations thereof.

The reset type can also be specified. This is not related to GNSS, but to the way the software restarts the system.

- **Hardware reset** uses the on-chip watchdog, to electrically reset the chip. This is an immediate, asynchronous reset. No Stop event is generated.
- **Controlled software reset** terminates all running processes in an orderly manner and, once the system is idle, restarts operation, reloads its configuration and starts to acquire and track GNSS satellites.
- **Controlled software reset (GNSS only)** only restarts the GNSS tasks, without reinitializing the full system or reloading any stored configuration.
- **Hardware reset (after shutdown)** uses the on-chip watchdog. This is a reset after shutdown.
- **Controlled GNSS stop** stops all GNSS tasks. The receiver will not be restarted, but will stop any GNSS-related processing.
- **Controlled GNSS start** starts all GNSS tasks.

3.13 Firmware upload

ZED-F9K is supplied with firmware. u-blox may release updated images containing, for example, security fixes, enhancements, bug fixes, etc. Therefore it is important that customers implement a firmware update mechanism in their system.

A firmware image is a binary file containing the software to be run by the GNSS receiver. A firmware update is the process of transferring a firmware image to the receiver and storing it in non-volatile flash memory.

Contact u-blox for more information on firmware update.

3.14 Spectrum analyzer

The UBX-MON-SPAN message provides a low-resolution RF spectrum analyzer function sufficient to identify noise or jammers in the receiver's reception band(s). It can be used for monitoring potential interferers during customer integration and in normal operation to identify interference, e.g. when the UBX-MON-RF message detects a possible jamming threat. See [Jamming/interference indicator](#) for more details. u-center provides a visualization of the message spectrum output(s) with features for max-hold and averaging.

 This message is intended for comparative analysis of the RF spectrum rather than absolute and precise measurement.

The message is output once per second when enabled. Depending on the receiver type, one or two measurement blocks will be output, indicated by the numRfBlocks flag field. The first block provides L1 spectrum data which can be followed by an L2 or L5 block with multi-band receivers.

Each block comprises the following data:

- 256 spectrum data points (0.25 dB units)
- Spectrum span (Hz)
- Spectrum bin resolution (Hz)
- Center frequency (Hz)
- PGA setting (dB)

The frequency of each point can be calculated by $\text{Freq}(i) = \text{center frequency} + \text{spectrum span} * (i-128) / 256$, where $i=0-255$. The number of points = span/resolution and is scaled in units of 0.25 dB. Changes in the PGA gain value can indicate an increased input in RF signal activity compared to normal operation.

Figure 34 shows the spectrum view in u-center with the view/hold option selected. The red line represents the frozen spectrum before modifying the external gain, while the black line represents the current measurement.

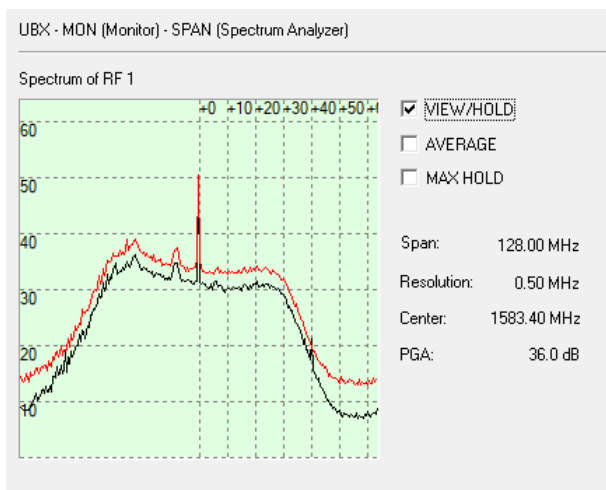



Figure 34: Spectrum analyzer view in u-center with the option view/hold selected

 The span frequency depends on the number of constellations enabled which impacts the spectrum resolution owing to a fixed set of points. For further details about this message see the interface description [2].



A spur may be visible at the center frequency, this comes internally from the receiver and does not cause any performance degradation.

4 Design

This section provides information to help carry out a successful schematic and PCB design integrating the ZED-F9K.

4.1 Pin assignment

The pin assignment of the ZED-F9K module is shown in [Figure 35](#). The defined configuration of the PIOs is listed in [Table 30](#).

The ZED-F9K is an LGA package with the I/O on the outside edge and central ground pads.

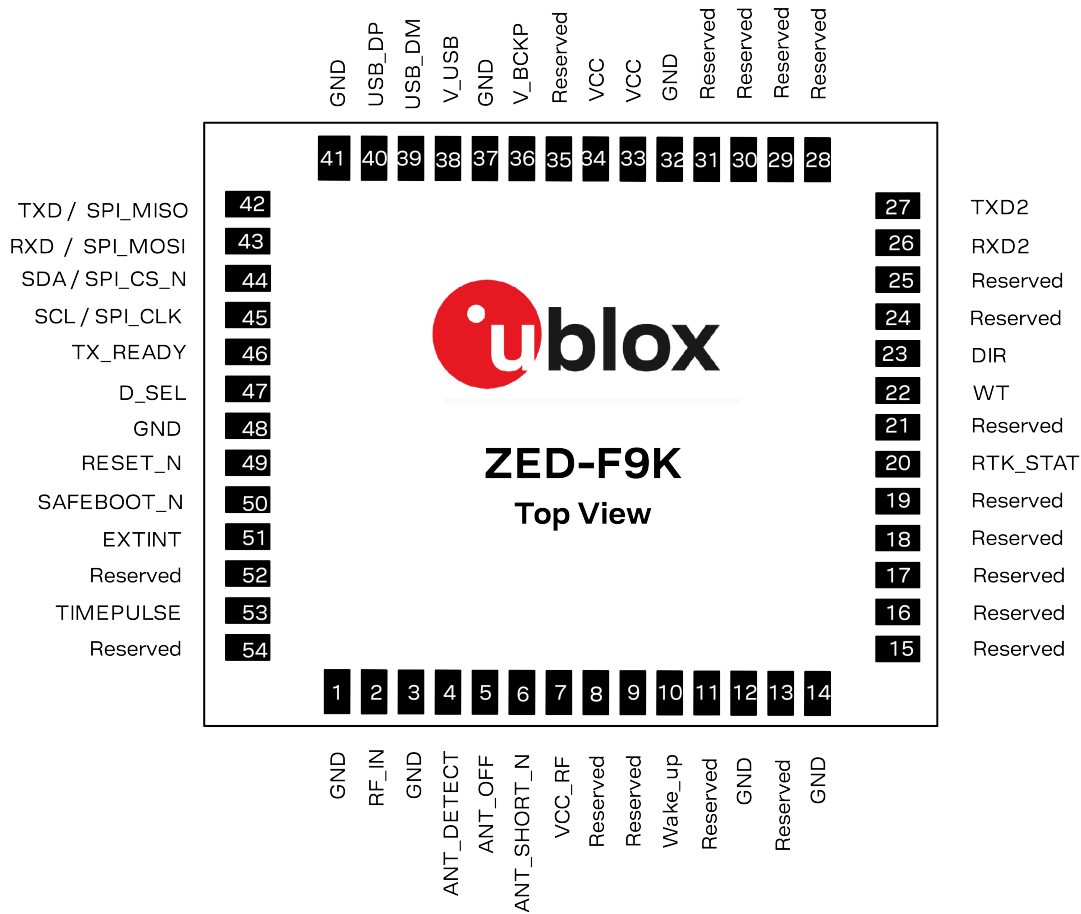

Figure 35: ZED-F9K pin assignment

Pin no.	Name	I/O	Description
1	GND	-	Ground
2	RF_IN	I	RF input
3	GND	-	Ground
4	ANT_DETECT	I	Active antenna detect
5	ANT_OFF	O	External LNA disable
6	ANT_SHORT_N	I	Active antenna short detect
7	VCC_RF	O	Voltage for external LNA

Pin no.	Name	I/O	Description
8	Reserved	-	Reserved
9	Reserved	-	Reserved
10	Wake_Up	O	Wake on motion
11	Reserved	-	Reserved
12	GND	-	Ground
13	Reserved	-	Reserved
14	GND	-	Ground
15	Reserved	-	Reserved
16	Reserved	-	Reserved
17	Reserved	-	Reserved
18	Reserved	-	Reserved
19	Reserved	-	Reserved
20	RTK_STAT	O	RTK status 0 – fixed, blinking – receiving and using corrections, 1 – no corrections
21	Reserved	-	Reserved
22	WT	I	Wheel ticks
23	DIR	I	Direction
24	Reserved	-	Reserved
25	Reserved	-	Reserved
26	RXD2	I	Correction UART input
27	TXD2	O	Correction UART output
28	Reserved	-	Reserved
29	Reserved	-	Reserved
30	Reserved	-	Reserved
31	Reserved	-	Reserved
32	GND	-	Ground
33	VCC	I	Voltage supply
34	VCC	I	Voltage supply
35	Reserved	-	Reserved
36	V_BCKP	I	Backup supply voltage
37	GND	-	Ground
38	V_USB	I	USB power input
39	USB_DM	I/O	USB data
40	USB_DP	I/O	USB data
41	GND	-	Ground
42	TXD / SPI_SDO	O	Serial port if D_SEL = 1 (or open). SPI SDO if D_SEL = 0
43	RXD / SPI_SDI	I	Serial port if D_SEL = 1 (or open). SPI SDI if D_SEL = 0
44	SDA / SPI_CS_N	I/O	I2C data if D_SEL = 1 (or open). SPI chip select if D_SEL = 0
45	SCL / SPI_CLK	I/O	I2C Clock if D_SEL = 1 (or open). SPI clock if D_SEL = 0
46	TX_READY	O	TX_Buffer full and ready for TX of data
47	D_SEL	I	Interface select
48	GND	-	Ground
49	RESET_N	I	RESET_N
50	SAFEBOOT_N	I	SAFEBOOT_N (for future service, updates and reconfiguration, leave OPEN)

Pin no.	Name	I/O	Description
51	EXT_INT	I	External interrupt pin
52	Reserved	-	Reserved
53	TIMEPULSE	O	Time pulse
54	Reserved	-	Reserved

Table 30: ZED-F9K pin assignment





4.2 Power supply

The u-blox ZED-F9K module has three power supply pins: VCC, V_BCKP and V_USB.

4.2.1 VCC: Main supply voltage

The **VCC** pin is connected to the main supply voltage. During operation, the current drawn by the module can vary by some orders of magnitude. For this reason, it is important that the supply circuitry be able to support the peak power for a short time (see the applicable data sheet [1] for specification).

The module integrates a DC/DC converter, which allows reduced power consumption.

-  When switching from backup mode to normal operation or at startup, u-blox ZED-F9K modules must charge the internal capacitors in the core domain. In certain situations, this can result in a significant current draw. For low-power applications using backup mode, it is important that the power supply or low ESR capacitors at the module input can deliver this current/charge.
-  To reduce peak current during power on, users can employ an LDO that has a built-in current limiter.
-  Do not add any series resistance greater than 0.2 Ω to the VCC supply as it will generate input voltage noise due to dynamic current conditions.
-  For the ZED-F9K module the equipment must be supplied by an external limited power source in compliance with the clause 2.5 of the standard IEC 60950-1.



4.2.2 V_BCKP: Backup supply voltage

The **V_BCKP** pin can be used to provide power to maintain the real-time clock (RTC) and battery-backed RAM (BBR) when VCC is removed.

V_BCKP can be provided with a battery. If V_BCKP is provided during a VCC outage, the receiver may be able to perform a hot or warm start. Especially if the RTC and BBR contents are still current, for example, after a short VCC outage. The fusion filter data is also stored in BBR and ZED-F9K can restart in fusion mode.

If V_BCKP is not provided, the module performs a cold start at power up. Also sensors will need to be recalibrated.

If a host is connected to ZED-F9K, V_BCKP can be partially emulated by using UBX-UPD-SOS functionality. BBR data can be saved to the host and restored at startup. See the applicable [Interface description](#) for more information.

-  Avoid high resistance on the **V_BCKP** line: During the switch from main supply to backup supply, a short current adjustment peak can cause a high voltage drop on the pin with possible malfunctions.
-  If no backup supply voltage is available, connect the **V_BCKP** pin to **VCC**.
-  Allow all I/O including UART and other interfaces to float or connect to a high impedance in HW backup mode (V_BCKP supplied when VCC is removed). See the [Interfaces](#) section.

Real-time clock (RTC)

The real-time clock (RTC) is driven by a 32-kHz oscillator using an RTC crystal. If VCC is removed while a battery is connected to **V_BCKP**, most of the receiver is switched off leaving the RTC and BBR powered. This operating mode is called Hardware Backup Mode which enables time keeping and all relevant data to be saved to allow a hot or warm start.

4.2.3 ZED-F9K power supply

The ZED-F9K requires a low-noise, low-dropout voltage, and a very low source impedance power supply of 3.3 V typically. No inductors or ferrite beads should be used from LDO to the module VCC pin. The peak currents need to be taken into account for the source supplying the LDO for the module.

A power supply fed by 5 V is shown in the figure below. This example circuit is intended only for the module supply.

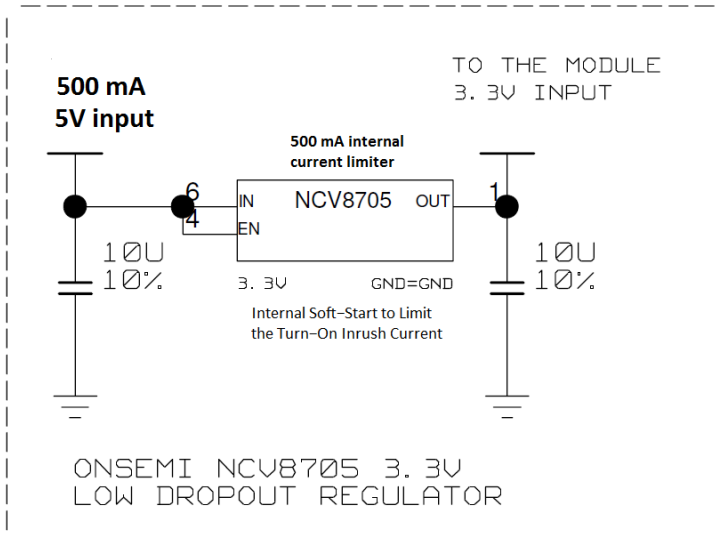

Figure 36: ZED-F9K power supply

4.3 ZED-F9K minimal design

The minimal electrical circuit for ZED-F9K operation using the UART1 interface is shown in [Figure 37](#) below.

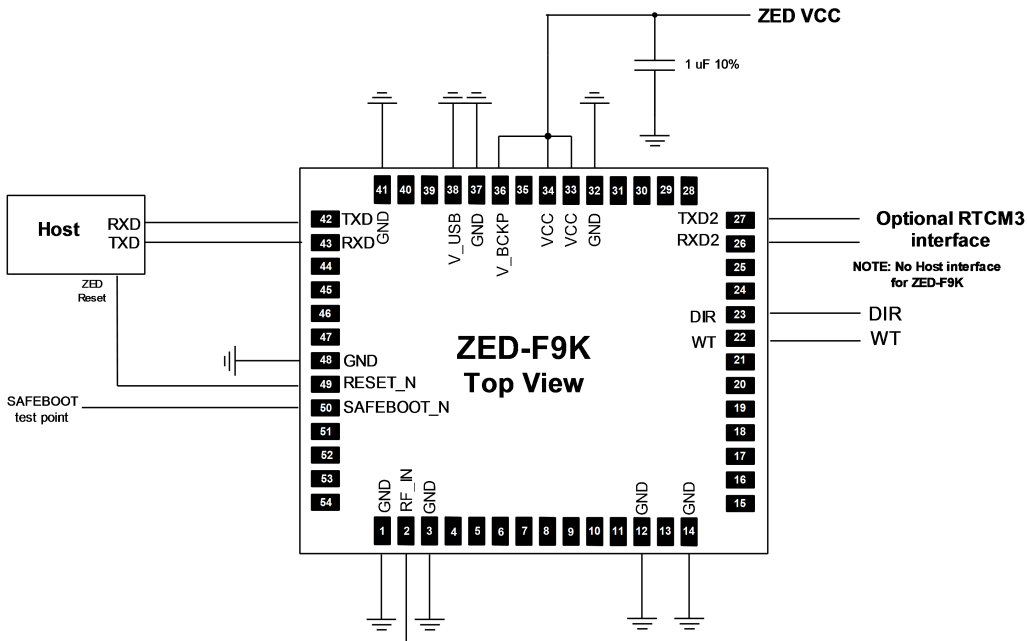

Figure 37: Minimal ZED-F9K design

For a minimal design with the ZED-F9K GNSS modules, the following functions and pins should be considered:

- Connect the power supply to VCC and V_BCKP.
- If hot or warm start operations are needed, connect a backup battery to V_BCKP.
- If USB is not used connect V_USB to ground.
- Ensure an optimal ground connection to all ground pins of the ZED-F9K GNSS module.
- If antenna bias is required, see ZED-F9K [antenna bias](#) section.

The host interface typically supplies the RTCM messages required for RTK operation.

4.4 WT and DIR interface example

This section shows an example design for interfacing the WT and DIR pins.

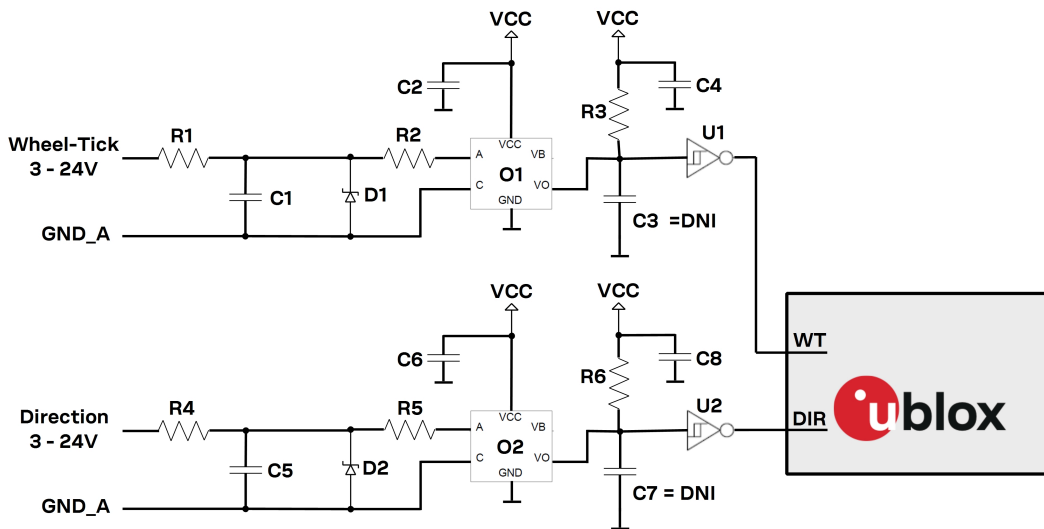
Figure 38: Example WT and DIR design

ID	Description
R1	RES THICK FILM CHIP 0603 3K3 5% 0.1W
R2	RES THICK FILM CHIP 0603 470R 5% 0.1W
R3	RES THICK FILM CHIP 0603 910R 5% 0.1W
R4	RES THICK FILM CHIP 0603 3K3 5% 0.1W
R5	RES THICK FILM CHIP 0603 470R 5% 0.1W
R6	RES THICK FILM CHIP 0603 910R 5% 0.1W
C1	CAP CER X7R 0603 1N 10% 25V
C2	CAP CER X7R 0603 100N 10% 10V
C3	CAP CER X7R 0603 22N 10% 10V
C4	CAP CER X7R 0603 100N 10% 10V
C5	CAP CER X7R 0603 1N 10% 25V
C6	CAP CER X7R 0603 100N 10% 10V
C7	CAP CER X7R 0603 22N 10% 10V
C8	CAP CER X7R 0603 100N 10% 10V
D1	VOLTAGE REGULATOR DIODE FAIRCHILD BZX84 SOT23 6V2 0.2A
D2	VOLTAGE REGULATOR DIODE FAIRCHILD BZX84 SOT23 6V2 0.2A
O1	OPTOCOUPLER LVTTTL/LVCMOS COMPATIBLE AVAGO HCPL-070L-000E SO8
O2	OPTOCOUPLER LVTTTL/LVCMOS COMPATIBLE AVAGO HCPL-070L-000E SO8
U1	TINY LOGIC UHS INVERTER WITH SCHMITT TRIGGER FAIRCHILD NC7SZ14 SOT23-5
U2	TINY LOGIC UHS INVERTER WITH SCHMITT TRIGGER FAIRCHILD NC7SZ14 SOT23-5

Table 31: WT and DIR example

4.5 Antenna

The ZED-F9K requires an active antenna with an integrated LNA to ensure good performance under nominal signal reception.

When implementing a custom antenna installation, it is recommended that an OEM active antenna module be used that meets our specification. Implementing a custom active antenna design is an

important exercise to meet the required bandwidths and group delay specifications compared to previous L1-only designs.

A typical dual band antenna design block diagram is shown below taken from the u-blox ANN-MB active antenna product.

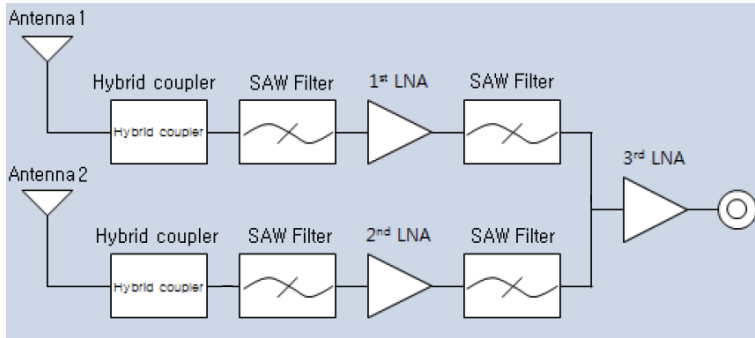

Figure 39: u-blox low cost dual-band antenna internal structure

- A suitable ground plane is required for the antenna to achieve good performance.
- Location of the antenna is critical to reach the stated performance. Unsuitable locations within a vehicle could include, under vehicle dash, rear-view mirror location, etc.
- It is recommended to mount the antenna on the roof top of the car or a location unobstructed by the user.

A set of recommended specifications for a dual band active antenna is given below.

Parameter	Specification	
Active antenna recommendations	Minimum gain ⁴	17 dB
	Maximum gain ⁴	50 dB
	Noise figure	<4 dB
Group delay variation in-band ⁵	10 ns max at each GNSS system bandwidth. Note: Inter-signal requirement 50 ns max.	
Out-of-band rejection	40 dB typ	
Antenna element specification	L1 band antenna gain ⁶	1559 - 1606 MHz: 3 dBic typ.
	L2/E5b band antenna gain ⁶	1197 - 1249 MHz: 2 dBic typ.
	L5/E5a band antenna gain ⁶	1164 - 1188 MHz: 2 dBic typ.
	Polarization	RHCP
	Axial ratio	2 dB max, at Zenith
Phase center variation	<10 mm over elevation/azimuth	
EMI immunity out-of-band ⁷	30 V/m	
ESD circuit protection	15 kV human body model air discharge	

Table 32: Antenna specifications for ZED-F9K modules

⁴ Including passive losses (filters, cables, connectors etc.)

⁵ GNSS system bandwidths: B1I 1559... 1563 MHz; L1,E1,B1C 1573... 1578 MHz; L1OF 1598... 1606 MHz; E5b,B2I 1192... 1212 MHz; L2C 1223... 1231 MHz; L2OF 1242... 1249 MHz

⁶ Measured with a ground plane d=150 mm



⁷ Exception L1,L2 ,L5 bands +/- 200 MHz, emphasis on cellular bands

The antenna system should include filtering to ensure adequate protection from nearby transmitters. Take care in the selection of antennas placed close to cellular or Wi-Fi transmitting antennas.

4.5.1 Antenna bias

Active antennas have an integrated low-noise amplifier that contributes an additional current of typically 5 to 20 mA to the system's power consumption budget.

If customers do not want to make use of the antenna supervisor function the filtered VCC_RF supply voltage output can supply the antenna if the supply voltage of the ZED-F9K module matches the antenna working voltage (e.g. 3.0 V).

-  A series current limiting resistor is required to prevent short circuits destroying the bias-t inductor.
-  The bias-t inductor must be chosen for multi-band operation, a value of 47 nH $\pm 5\%$ is recommended for the recommended Murata L part. It has a self-resonance frequency of 1 GHz and a high impedance ($> 500 \Omega$) at L-band frequencies.

The recommended bias-t inductor (Murata LQG15HS47NJ02) has a maximum current capacity of 300 mA. Hence the current is limited to 70 mA at 3.3V using an active limiter in the recommended circuit shown in [Figure 41](#) below. A 10 Ω resistor (R2) is provided to measure the current. This resistor power rating must be chosen to ensure reliability in the chosen circuit design.

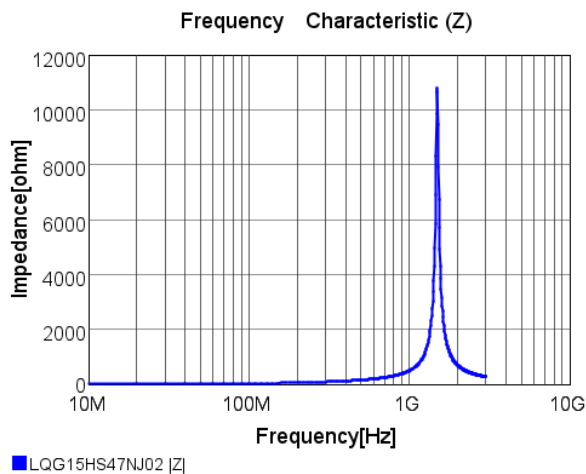

Figure 40: ZED-F9K antenna bias inductor impedance

A recommended circuit design for an active antenna bias is shown below. This example shows an external voltage of 3.3 V with current limiting as described above. An ESD protection diode should also be connected to the input as shown.

RF INPUT AND ANTENNA BIAS

NOTE:

BIAS-CIRCUITRY LIMITS THE CURRENT TO ~70MA

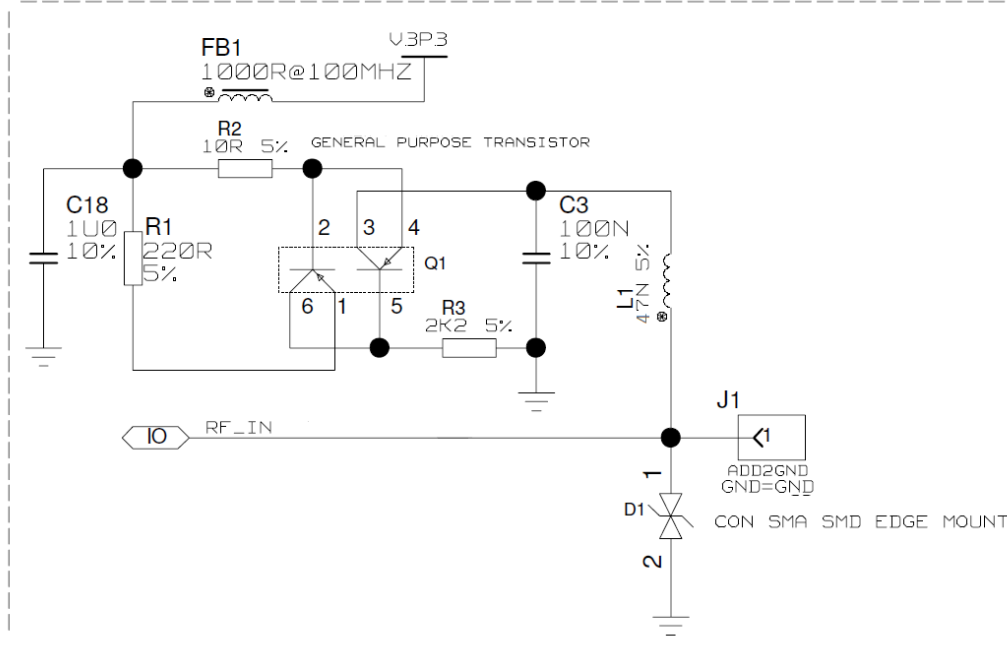
Figure 41: ZED-F9K reference design for antenna bias

L1: Murata LQG15HS47NJ02 0402 47 N 5% 0.30 A -55/+125 C

D1: TYCO, 0.25PF, PESD0402-140 -55/+125C

C3: MURATA GRM033R61E104KE14 CER X5R 0201 100N 10% 25V

R2: RES THICK FILM CHIP 1206 10R 5% 0.25W

It is recommended to use active current limiting. If active current limiting is not used, the important points covered below need to be taken into account:

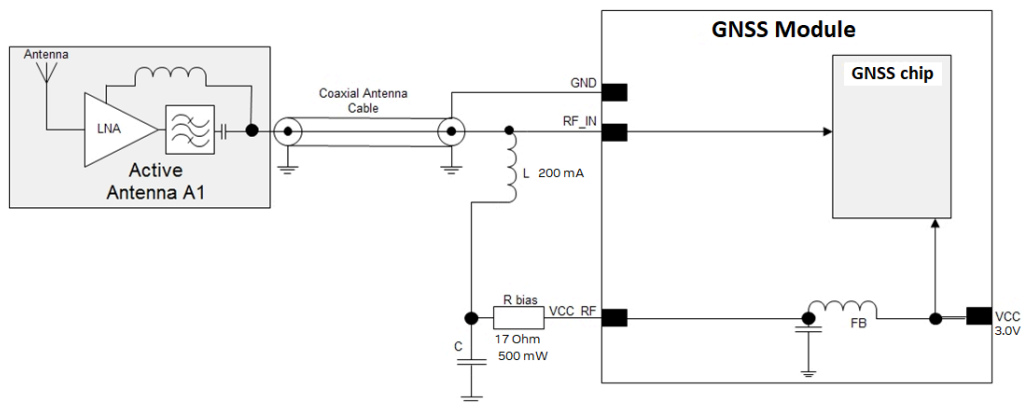
Figure 42: ZED-F9K VCC_RF antenna bias

The bias-t inductor and current limiting resistor must be selected to be reliable with a short circuit on the antenna feed if no active current limiter is used. Our recommended part has a limit of 300 mA. A part with a higher current capability will be needed if the short circuit current is as described here. This will also be affected by the voltage level of the antenna bias supply due to

power dissipation. Take the current limit capability of the antenna bias supply into consideration. In the case where the module supplies the voltage via VCC_RF , a higher value resistor will be needed to ensure the module supply inductor is protected. The current should be limited to below 150 mA at the module supply voltage under short circuit conditions. In this case a value of 17 Ω or more is required at a module supply of 3 V to limit short circuit current to 150 mA. The DC resistance of the bias-t inductor is assumed to be 1-2 Ω and the module internal feed inductor is assumed to be 1.2 Ω .

If the VCC_RF voltage does not match with the supply voltage of the active antenna, use a filtered external supply.



The power dissipation in the resistor and inductor needs to be taken into account based on the supply voltage and short circuit current. The bias-t inductor current capability and the bias resistor value need to be calculated as shown above. The supply voltage for the bias-t and its current capability is part of the calculation.

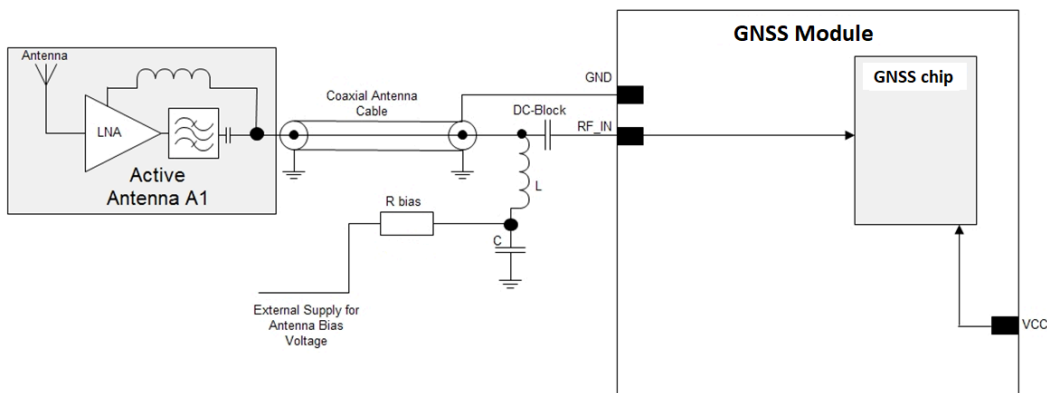

Figure 43: ZED-F9K external voltage antenna bias

4.6 EOS/ESD precautions

- ⚠ To avoid overstress damage during production or in the field it is essential to observe strict EOS/ESD/EMI handling and protection measures.
- ⚠ To prevent overstress damage at the RF_IN of your receiver, never exceed the maximum input power as specified in the applicable data sheet [1].

When integrating GNSS receivers into wireless systems, pay special attention to electromagnetic and voltage susceptibility issues. Wireless systems include components which can produce Electrostatic Discharge (ESD), Electrical Overstress (EOS) and Electro-Magnetic Interference (EMI). CMOS devices are more sensitive to such influences because their failure mechanism is defined by the applied voltage, whereas bipolar semiconductors are more susceptible to thermal overstress. The following design guidelines help in designing robust yet cost-effective solutions.

4.6.1 ESD protection measures

- ⚠ GNSS receivers are sensitive to Electrostatic Discharge (ESD). Special precautions are required when handling. Most defects caused by ESD can be prevented by following strict ESD protection rules for production and handling. When implementing passive antenna patches or external antenna connection points, then additional ESD measures as shown in the figure below can also avoid failures in the field.

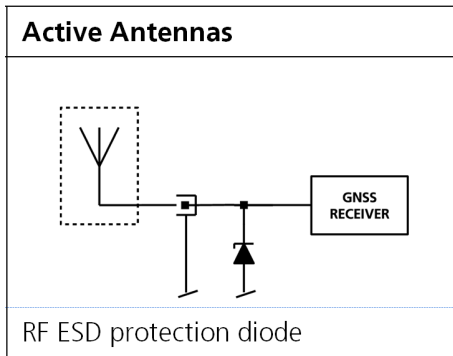

Figure 44: RF ESD precautions

4.6.2 EOS precautions

Electrical overstress (EOS) usually describes situations when the maximum input power exceeds the maximum specified ratings. EOS failure can happen if RF emitters are close to a GNSS receiver or its antenna. EOS causes damage to the chip structures. If the RF_IN is damaged by EOS, it is hard to determine whether the chip structures have been damaged by ESD or EOS.

EOS protection measures as shown in the figure below are recommended for any designs combining wireless communication transceivers (e.g. GSM, GPRS) and GNSS in the same design or in close proximity.

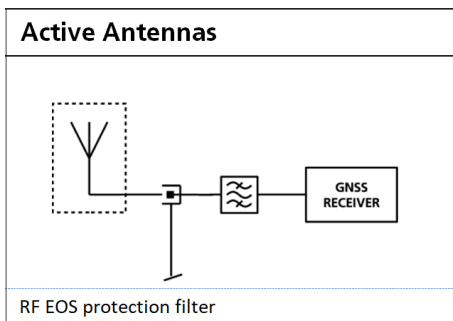

Figure 45: Active antenna EOS protection

4.6.3 Safety precautions

The ZED-F9K must be supplied by an external limited power source in compliance with the clause 2.5 of the standard IEC 60950-1. In addition to external limited power source, only Separated or Safety Extra-Low Voltage (SELV) circuits are to be connected to the module including interfaces and antennas.



For more information about SELV circuits see section 2.2 in Safety standard IEC 60950-1.

4.7 Electromagnetic interference on I/O lines

Any I/O signal line with a length greater than approximately 3 mm can act as an antenna and may pick up arbitrary RF signals transferring them as noise into the receiver. This specifically applies to unshielded lines, in which the corresponding GND layer is remote or missing entirely, and lines close to the edges of the printed circuit board.

If, for example, a cellular signal radiates into an unshielded high-impedance line, it is possible to generate noise in the order of volts and not only distort receiver operation but also damage it permanently. Another type of interference can be caused by noise generated at the PIO pins that

emits from unshielded I/O lines. Receiver performance may be degraded when this noise is coupled into the GNSS antenna.

EMI protection measures are particularly useful when RF emitting devices are placed next to the GNSS receiver and/or to minimize the risk of EMI degradation due to self-jamming. An adequate layout with a robust grounding concept is essential in order to protect against EMI.



Intended Use: In order to mitigate any performance degradation of a radio equipment under EMC disturbance, system integration shall adopt appropriate EMC design practice and not contain cables over three meters on signal and supply ports.

4.7.1 General notes on interference issues

Received GNSS signal power at the antenna is very low. At the nominal received signal strength (-128 dBm) it is below the thermal noise floor of -111 dBm. Due to this fact, a GNSS receiver is susceptible to interference from nearby RF sources of any kind. Two cases can be distinguished:

- Out-of-band interference: Typically any kind of wireless communications system (e.g. LTE, GSM, CDMA, 3G, WLAN, Bluetooth, etc.) may emit its specified maximum transmit power in close proximity to the GNSS receiving antenna, especially if such a system is integrated with the GNSS receiver. Even at reasonable antenna selectivity, destructive power levels may reach the RF input of the GNSS receiver. Also, larger signal interferers may generate intermodulation products inside the GNSS receiver front-end that fall into the GNSS band and contribute to in-band interference.
- In-band interference: Although the GNSS band is kept free from intentional RF signal sources by radio-communications standards, many devices emit RF power into the GNSS band at levels much higher than the GNSS signal itself. One reason is that the frequency band above 1 GHz is not well regulated with regards to EMI, and even if permitted, signal levels are much higher than GNSS signal power. Notably, all types of digital equipment, such as PCs, digital cameras, LCD screens, etc. tend to emit a broad frequency spectrum up to several GHz of frequency. Also wireless transmitters may generate spurious emissions that fall into GNSS band.

As an example, GSM uses power levels of up to 2 W (+33 dBm). The absolute maximum power input at the RF input of the GNSS receiver can be +15 dBm. The GSM specification allows spurious emissions for GSM transmitters of up to +36 dBm, while the GNSS signal is less than -128 dBm. By simply comparing these numbers it is obvious that interference issues must be seriously considered in any design of a GNSS receiver. Different design goals may be achieved through different implementations:

- The primary focus is to prevent damaging the receiver from large input signals. Here the GNSS performance under interference conditions is not important and suppression of the signal is permitted. It is sufficient to just observe the maximum RF power ratings of all of the components in the RF input path.
- GNSS performance must be guaranteed even under interference conditions. In such a case, not only the maximum power ratings of the components in the receiver RF path must be observed. Further, non-linear effects like gain compression, NF degradation (desensitization) and intermodulation must be analyzed.



Pulsed interference with a low-duty cycle such as GSM may be destructive due to the high peak power levels.

4.7.2 In-band interference mitigation

With in-band interference, the signal frequency is very close to the GNSS frequency. Such interference signals are typically caused by harmonics from displays, micro-controller operation, bus systems, etc. Measures against in-band interference include:

- Maintaining a good grounding concept in the design
- Shielding
- Layout optimization
- Low-pass filtering of noise sources, e.g. digital signal lines
- Remote placement of the GNSS antenna, far away from noise sources
- Adding an LTE, CDMA, GSM, WCDMA, BT band-pass filter before antenna

4.7.3 Out-of-band interference

Out-of-band interference is caused by signal frequencies that are different from the GNSS carrier frequency. The main sources are wireless communication systems such as LTE, GSM, CDMA, WCDMA, Wi-Fi, BT, etc.

Measures against out-of-band interference include maintaining a good grounding concept in the design and adding a GNSS band-pass filter into the antenna input line to the receiver.

For GSM applications, such as typical handset design, an isolation of approximately 20 dB can be reached with careful placement of the antennas. If this is insufficient, an additional SAW filter is required on the GNSS receiver input to block the remaining GSM transmitter energy.

4.8 Layout

This section details layout and placement requirements of the ZED-F9K high precision receiver.

4.8.1 Placement

GNSS signals at the surface of the Earth are below the thermal noise floor. A very important factor in achieving maximum GNSS performance is the placement of the receiver on the PCB. The placement used may affect RF signal loss from antenna to receiver input and enable interference into the sensitive parts of the receiver chain, including the antenna itself. When defining a GNSS receiver layout, the placement of the antenna with respect to the receiver, as well as grounding, shielding and interference from other digital devices are crucial issues and need to be considered very carefully.

Signal loss on the RF connection from antenna to receiver input must be minimized as much as possible. Hence, the connection to the antenna must be kept as short as possible.

Ensure that RF critical circuits are clearly separated from any other digital circuits on the system board. To achieve this, position the receiver digital part closer to the digital section of the system PCB and have the RF section and antenna placed as far as possible away from the other digital circuits on the board.

A proper GND concept shall be followed: The RF section shall not be subject to noisy digital supply currents running through its GND plane.

4.8.2 Thermal management

During design-in do not place the receiver near sources of heating or cooling. The receiver oscillator is sensitive to sudden changes in ambient temperature which can adversely impact satellite signal tracking. Sources can include co-located power devices, cooling fans or thermal conduction via the PCB. Take into account the following questions when designing in the receiver.

- Is the receiver placed away from heat sources?
- Is the receiver placed away from air-cooling sources?
- Is the receiver shielded by a cover/case to prevent the effects of air currents and rapid environmental temperature changes?

- ⚠ High temperature drift and air vents can affect the GNSS performance. For best performance, avoid high temperature drift and air vents near the receiver.

4.8.3 Package footprint, copper and paste mask

Copper and solder mask dimensioning recommendations for the ZED-F9K module packages are provided in this section.

- 👉 These are recommendations only and not specifications. The exact copper, solder and paste mask geometries, distances, stencil thickness and solder paste volumes must be adapted to the specific production processes (e.g. soldering etc.) of the customer.

Refer to the applicable data sheet [1] for the mechanical dimensions.

4.8.3.1 Footprint

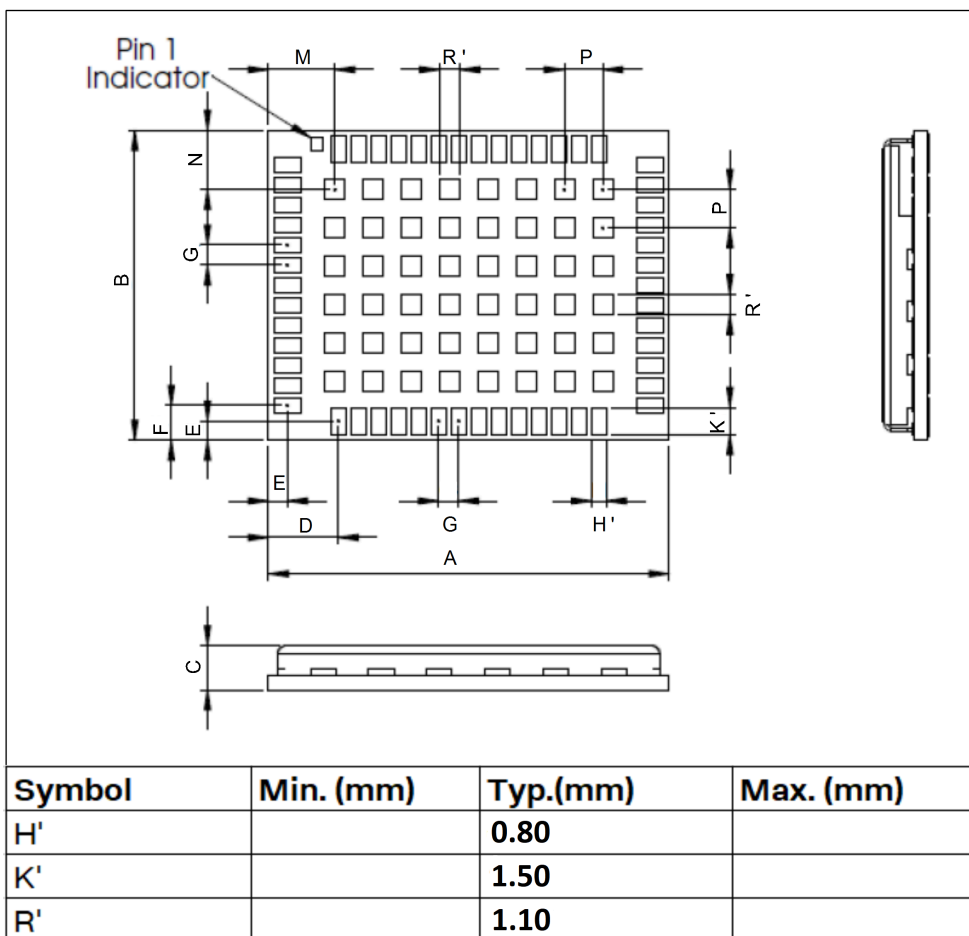

Figure 46: ZED-F9K suggested footprint (i.e. copper mask)

4.8.3.2 Paste mask

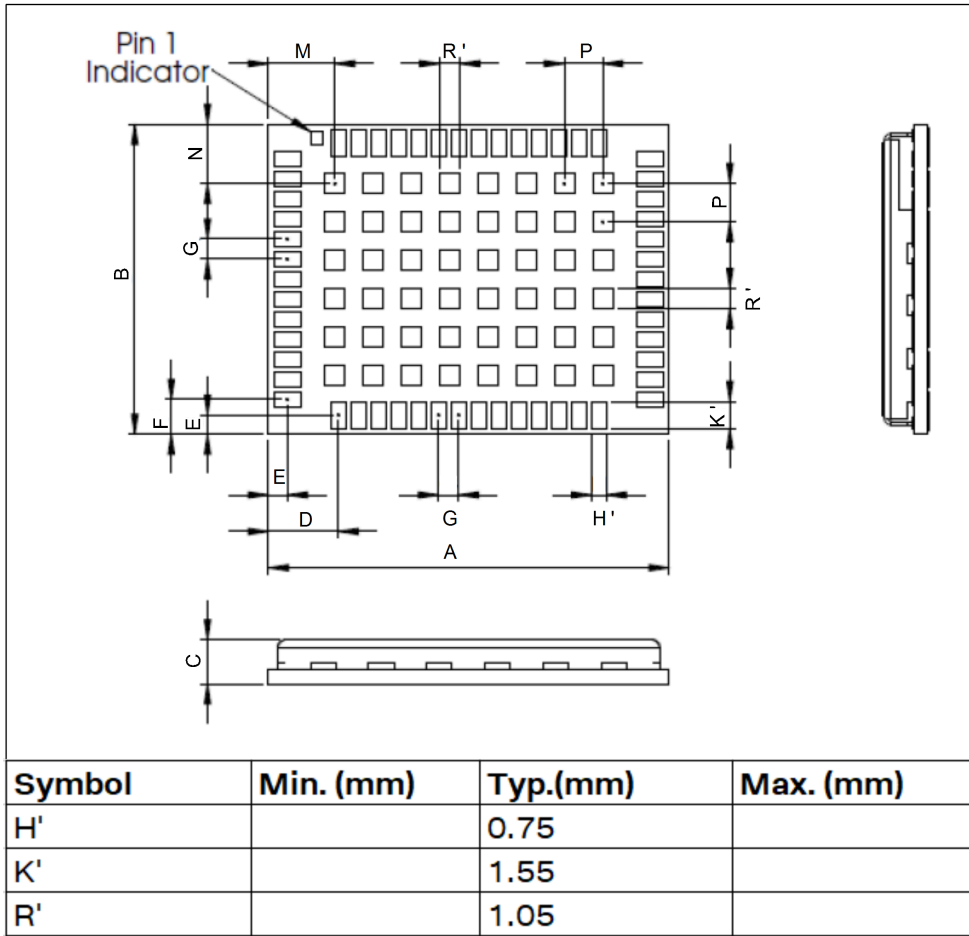

Figure 47: ZED-F9K suggested paste mask

4.8.4 Layout guidance

The presented layout guidance reduces the risk of performance issues at design level.

4.8.4.1 RF In trace

The RF in trace has to work in the combined GNSS signal bands.

For FR-4 PCB material with a dielectric permittivity of for example 4.7, the trace width for the 50 Ω line impedance can be calculated.

A grounded co-planar RF trace is recommended as it provides the maximum shielding from noise with adequate vias to the ground layer.

The RF trace must be shielded by vias to ground along the entire length of the trace and the ZED-F9K RF_IN pad should be surrounded by vias as shown in the figure below.

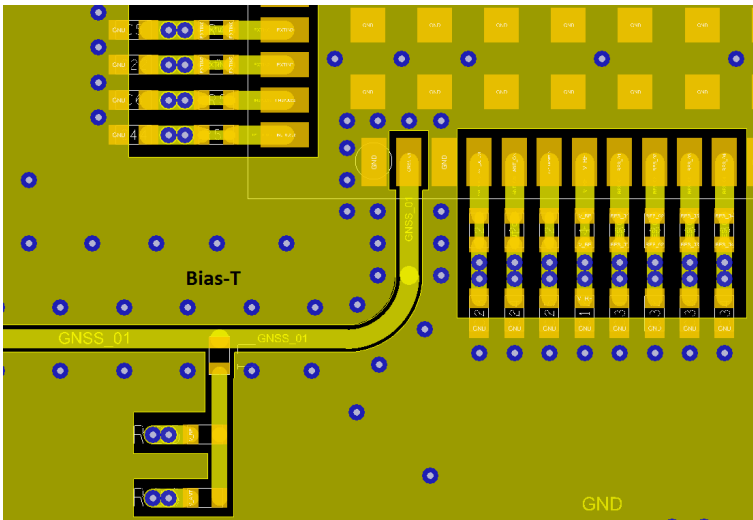

Figure 48: RF input trace

The RF_IN trace on the top layer should be referenced to a suitable ground layer.

4.8.4.2 Vias for the ground pads

The ground pads under the ZED-F9K high precision receiver need to be grounded with vias to the lower ground layer of the PCB. A solid ground layer fill on the top layer of the PCB is recommended. This is shown in the figure below.

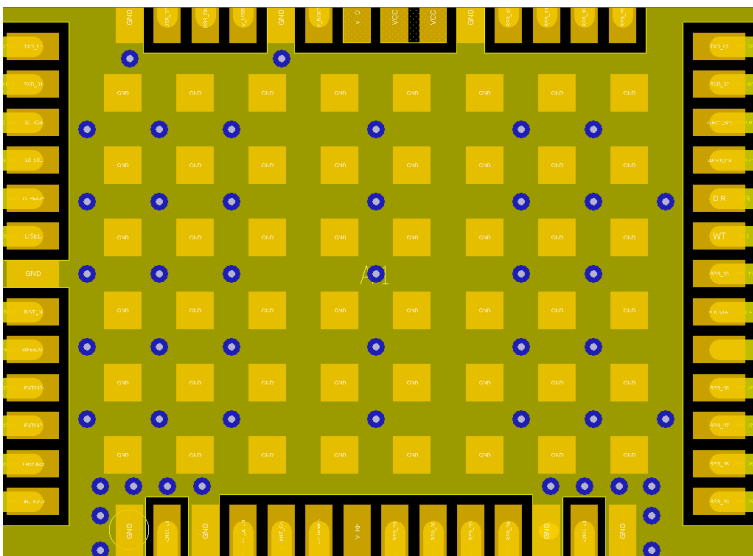

Figure 49: Top layer fill and vias

4.8.4.3 VCC pads

The VCC pads for the ZED-F9K high precision receiver must have as low impedance as possible with large vias to the lower power layer of the PCB. The VCC pads need a large combined pad and the decoupling capacitors must be placed as close as possible. This is shown in the figure below.

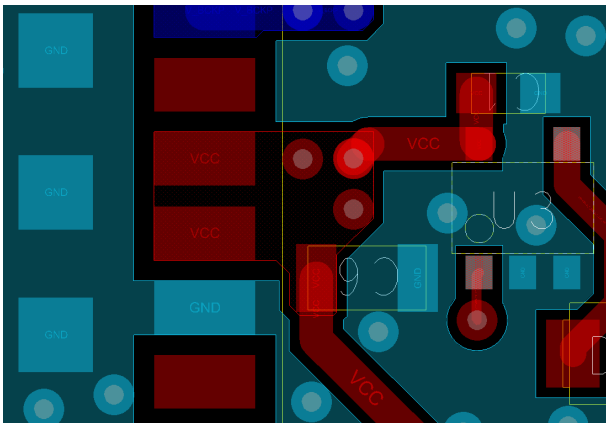

Figure 50: VCC pads

4.9 Design guidance

4.9.1 General considerations

Check power supply requirements and schematic:

- Is the power supply voltage within the specified range and noise-free?
- If USB is not used, connect the V_USB pin to ground.
- It is recommended to have a separate LDO for V_USB that is enabled by the module VCC. This is to comply with the USB self-powered specification.
- If USB is used, is there a 1 uF capacitor right near the V_USB pin? This is just for the V_USB pin.
- Is there a 1 uF cap right next to the module VCC pin?
- Compare the peak current consumption of the ZED-F9K GNSS module with the specification of your power supply.
- GNSS receivers require a stable power supply. Avoid series resistance (less than 0.2 Ω) in your power supply line (the line to VCC) to minimize the voltage ripple on VCC. See the ZED-F9K [Power supply](#) section in the [Design](#) chapter for more information on the power supply requirements.
- Allow all I/O to Float/High impedance (High-Z) when VCC is not applied.

4.9.2 Backup battery

Check backup supply requirements and schematic:

- For achieving a minimal time to first fix (TTFF) after a power down (warm starts, hot starts), make sure to connect a backup battery to V_BCKP.
- Verify that your battery backup supply can provide the battery backup current specified in the applicable data sheet.
- Allow all I/O including UART and other interfaces to Float/High impedance in HW backup mode (battery backup connected with VCC removed).

4.9.3 RF front-end circuit options



It is important that the RF input is fed by an active antenna meeting the requirements for the ZED-F9K.

The first stages of the signal processing chain are crucial to the overall receiver performance.

When an RF input connector is employed this can provide a conduction path for harmful or destructive electrical signals. If this is a likely factor the RF input should be protected accordingly.

Additional points on the RF input

- What is the expected quality of the signal source (antenna)?
- What is the external active antenna signal power?
- What is the bandwidth and filtering of the external active antenna?
- Does the external antenna and filtering components meet the group delay variation requirements? This is critical for high accuracy applications such as RTK and timing.

Are destructive RF power levels expected to reach the RF input? Is interference from wireless transmitters expected?

- What are the characteristics of these signals (duty cycle, frequency range, power range, spectral purity)?
- What is the expected GNSS performance under interference conditions?

Is there a risk of RF input exposure to excessive ESD stress?

- In the field: Can the user access the antenna connector?
- PCB / system assembly: Is there risk that statically charged parts (e.g. patch antennas) may be discharged through the RF input?

The following subsections provide several options addressing the various questions above:



In some applications, such as cellular transceivers, interference signals may exceed the maximum power rating of the RF_IN input. To avoid device destruction use of external input protection is mandatory.



During assembly of end-user devices which contain passive patch antennas, an ESD discharge may occur during production when pre-charged antennas are soldered to the GNSS receiver board. In such cases, use of external protection in front of RF_IN is mandatory to avoid device destruction.

ESD discharge cannot be avoided during assembly and / or field use. Note that SAW filters are susceptible to ESD damage. To provide additional robustness an ESD protection diode may be placed at the antenna RF connector to GND.

4.9.4 Antenna/RF input

Check RF input requirements and schematic:

- An OEM active antenna module that meets our requirements should be used if there is a need to integrate the antenna.
- The total maximum noise figure including external LNA (or the LNA in the active antenna) should be around 3 dB.
- Ensure active antenna gain is ideally between 30 - 40 dB gain.
- Make sure the antenna is not placed close to noisy parts of the circuitry and does not face any other noisy elements (for example microcontroller, display).
- Signal levels above 40 C/N0 average are required for optimal RTK performance.
- If a patch type antenna is used, an antenna ground plane with minimum 100 - 150 mm diameter is required.
- Ensure antenna supports both L1 and L2 bands.
- Ensure antenna element gain is between 2 and 3 dBic typical for each band.
- Ensure the group delay variation including active antenna is 10 ns max at each GNSS system bandwidth. Note: Inter-signal requirement 50 ns max.
- ESD protection on the RF input is mandatory.
- A Bias-T inductor must be selected with high impedance in the GNSS bands.

- Ensure RF trace is tuned for 50 Ω to ensure adequate bandwidth and power matching.

4.9.5 Ground pads

Ensure the ground pads of the module are connected to ground.

4.9.6 Schematic design

For a **minimal design** with the ZED-F9K GNSS modules, consider the following functions and pins:

- Connect the power supply to VCC and V_BCKP.
- V_USB: If USB is used it is recommended V_USB is to be powered as per USB self-powered mode specification.
- If USB is not used connect V_USB to ground.
- Ensure an optimal ground connection to all ground pins of the ZED-F9K GNSS module.
- Choose the required serial communication interfaces (UART, USB, SPI or I2C) and connect the appropriate pins to your application.
- If you need hot or warm start in your application, connect a backup battery to V_BCKP.
- Antenna bias is required, see ZED-F9K antenna bias section.

4.9.7 Layout design-in guideline

- Is the receiver placed away from heat sources?
- Is the receiver placed away from air-cooling sources?
- Is the receiver shielded by a cover/case to prevent the effects of air currents and rapid environmental temperature changes?
- Is the receiver placed as recommended in the [Layout](#) and [Layout guidance](#)?
- Assure a low serial resistance on the VCC power supply line (choose a line width > 400 μm).
- Keep the power supply line as short as possible.
- Add a ground plane underneath the module to reduce interference. This is especially important for the RF input line.
- For improved shielding, add as many vias as possible around the micro strip/co-planar waveguide, around the serial communication lines, underneath the module, etc.

5 Product handling

5.1 ESD handling precautions

 ZED-F9K contains highly sensitive electronic circuitry and is an Electrostatic Sensitive Device (ESD). Observe precautions for handling! Failure to observe these precautions can result in severe damage to the GNSS receiver!

- Unless there is a galvanic coupling between the local GND (i.e. the work table) and the PCB GND, then the first point of contact when handling the PCB must always be between the local GND and PCB GND.
- Before mounting an antenna patch, connect ground of the device.



- When handling the RF pin, do not come into contact with any charged capacitors and be careful when contacting materials that can develop charges (e.g. patch antenna ~10 pF, coax cable ~50-80 pF/m or soldering iron).



- To prevent electrostatic discharge through the RF input, do not touch any exposed antenna area. If there is any risk that such exposed antenna area is touched in non-ESD protected work area, implement proper ESD protection measures in the design.

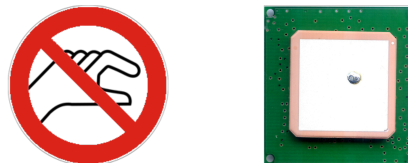

- When soldering RF connectors and patch antennas to the receiver's RF pin, make sure to use an ESD-safe soldering iron (tip)



5.2 Soldering

Soldering paste

Use of “no clean” soldering paste is highly recommended, as it does not require cleaning after the soldering process. The paste in the example below meets these criteria.

- Soldering paste: OM338 SAC405 / Nr.143714 (Cookson Electronics)
- Alloy specification: Sn 95.5/ Ag 4/ Cu 0.5 (95.5% tin/ 4% silver/ 0.5% copper)
- Melting temperature: 217 °C
- Stencil thickness: The exact geometry, distances, stencil thicknesses and solder paste volumes must be adapted to the customer's specific production processes (e.g. soldering).

Reflow soldering

A convection-type soldering oven is highly recommended over the infrared-type radiation oven. Convection-heated ovens allow precise control of the temperature, and all parts will heat up evenly, regardless of material properties, thickness of components and surface color.

As a reference, see “IPC-7530 Guidelines for temperature profiling for mass soldering (reflow and wave) processes”, published in 2001.

Preheat phase

During the initial heating of component leads and balls, residual humidity will be dried out. Note that the preheat phase does not replace prior baking procedures.

- Temperature rise rate: max 3 °C/s. If the temperature rise is too rapid in the preheat phase, excessive slumping may be caused
- Time: 60 – 120 s. If the preheat is insufficient, rather large solder balls tend to be generated. Conversely, if performed excessively, fine balls and large balls will be generated in clusters
- End temperature: 150 – 200 °C. If the temperature is too low, non-melting tends to be caused in areas containing large heat capacity

Heating - reflow phase

The temperature rises above the liquidus temperature of 217 °C. Avoid a sudden rise in temperature as the slump of the paste could become worse.

For professional grade modules

- Limit time above 217 °C liquidus temperature: 40 – 60 s
- Peak reflow temperature: 245 °C

For automotive grade modules

- Limit time above 217 °C liquidus temperature: 60 – 150 s
- Peak reflow temperature: 250 °C

Cooling phase

A controlled cooling prevents negative metallurgical effects of the solder (solder becomes more brittle) and possible mechanical tensions in the products. Controlled cooling helps to achieve bright solder fillets with a good shape and low contact angle.

For professional grade modules

- Temperature fall rate: max 4 °C/s

For automotive grade modules

- Temperature fall rate: max 6 °C/s



To avoid falling off, the modules should be placed on the topside of the motherboard during soldering.

The final soldering temperature chosen at the factory depends on additional external factors such as the choice of soldering paste, size, thickness and properties of the base board, etc. Exceeding the maximum soldering temperature in the recommended soldering profile may permanently damage the module.

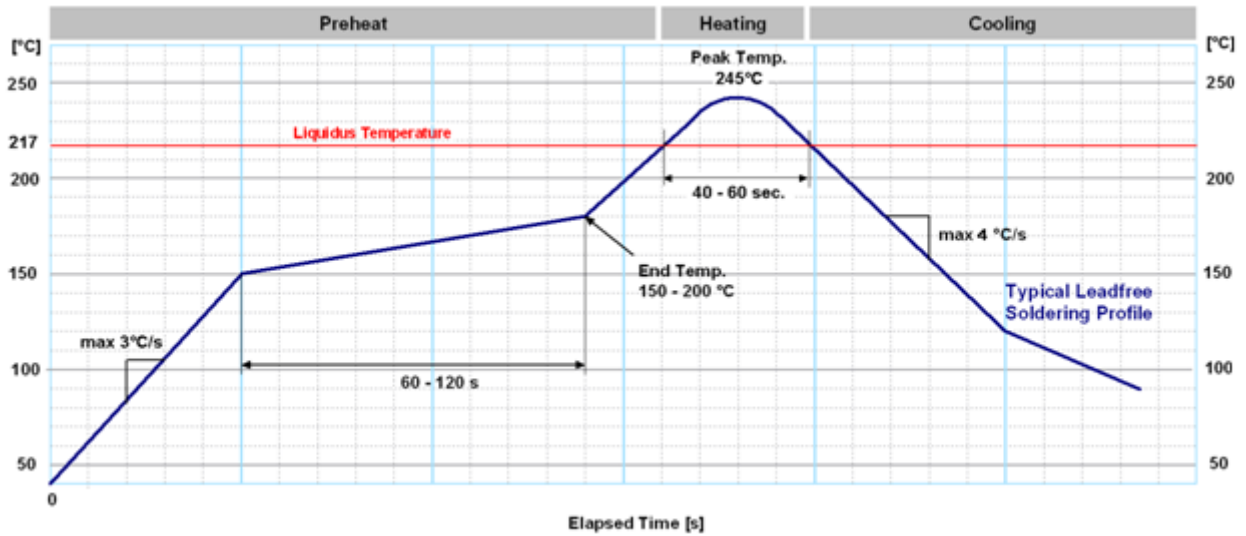

Figure 51: Soldering profile for professional grade ZED-F9K

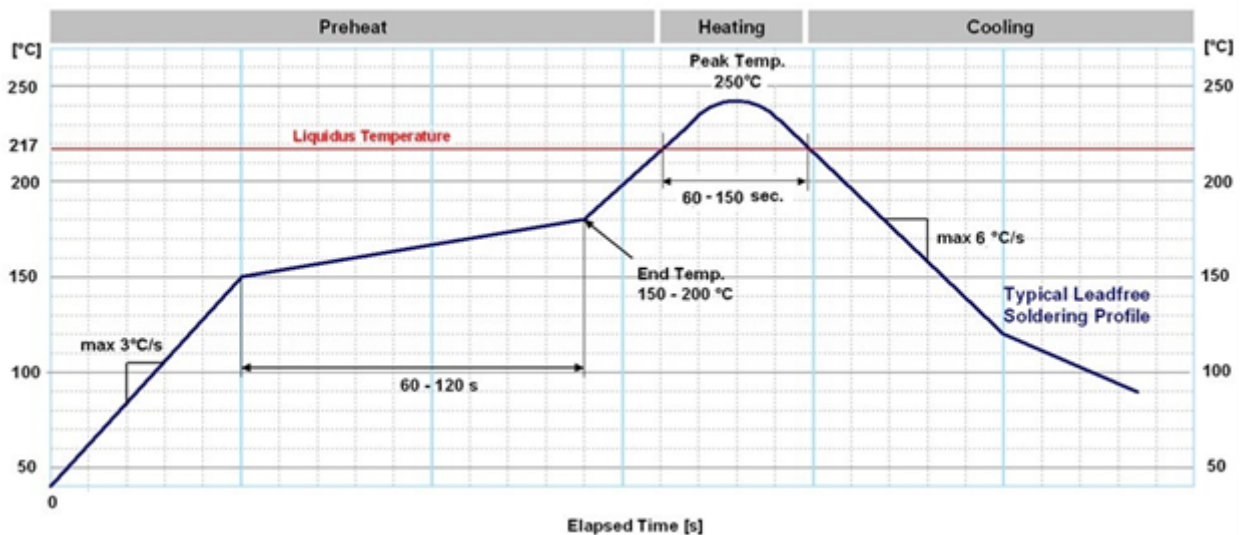

Figure 52: Soldering profile for automotive grade ZED-F9K

Modules **must not** be soldered with a damp heat process.

Optical inspection

After soldering the module, consider optical inspection.

Cleaning

Do not clean with water, solvent, or ultrasonic cleaner:

- Cleaning with water will lead to capillary effects where water is absorbed into the gap between the baseboard and the module. The combination of residues of soldering flux and encapsulated water leads to short circuits or resistor-like interconnections between neighboring pads.
- Cleaning with alcohol or other organic solvents can result in soldering flux residues flowing underneath the module, into areas that are not accessible for post-cleaning inspections. The solvent will also damage the sticker and the printed text.
- Ultrasonic cleaning will permanently damage the module, in particular the quartz oscillators.

The best approach is to use a "no clean" soldering paste and eliminate the cleaning step after the soldering.

Repeated reflow soldering

-  Repeated reflow soldering processes or soldering the module upside down are not recommended.

A board that is populated with components on both sides may require more than one reflow soldering cycle. In such a case, the process should ensure the module is only placed on the board submitted for a single final upright reflow cycle. A module placed on the underside of the board may detach during a reflow soldering cycle due to lack of adhesion.

The module can also tolerate an additional reflow cycle for rework purposes.

Wave soldering

Base boards with combined through-hole technology (THT) components and surface-mount technology (SMT) devices require wave soldering to solder the THT components. Only a single wave soldering process is encouraged for boards populated with modules.

Rework

We do not recommend using a hot air gun because it is an uncontrolled process and can damage the module.

-  Use of a hot air gun can lead to overheating and severely damage the module. Always avoid overheating the module.

After the module is removed, clean the pads before reapplying solder paste, placing and reflow soldering a new module.

-  Never attempt a rework on the module itself, e.g. by replacing individual components. Such actions will immediately void the warranty.

Conformal coating

Certain applications employ a conformal coating of the PCB using HumiSeal® or other related coating products. These materials affect the RF properties of the GNSS module and it is important to prevent them from flowing into the module. The RF shields do not provide 100% protection for the module from coating liquids with low viscosity. Apply the coating carefully.

-  Conformal coating of the module will void the warranty.

Casting

If casting is required, use viscose or another type of silicon pottant. The OEM is strongly advised to qualify such processes in combination with the module before implementing this in the production.

-  Casting will void the warranty.

Grounding metal covers

Attempts to improve grounding by soldering ground cables, wick or other forms of metal strips directly onto the EMI covers is done at the customer's own risk. The numerous ground pins should be sufficient to provide optimum immunity to interferences and noise.

-  u-blox makes no warranty for damages to the module caused by soldering metal cables or any other forms of metal strips directly onto the EMI covers.

Use of ultrasonic processes

Some components on the module are sensitive to ultrasonic waves. Use of any ultrasonic processes (cleaning, welding etc.) may cause damage to the GNSS receiver.

 u-blox offers no warranty against damages to the module caused by ultrasonic processes.

5.3 Tapes

Figure 53 shows the feed direction and illustrates the orientation of the ZED-F9Ks on the tape:

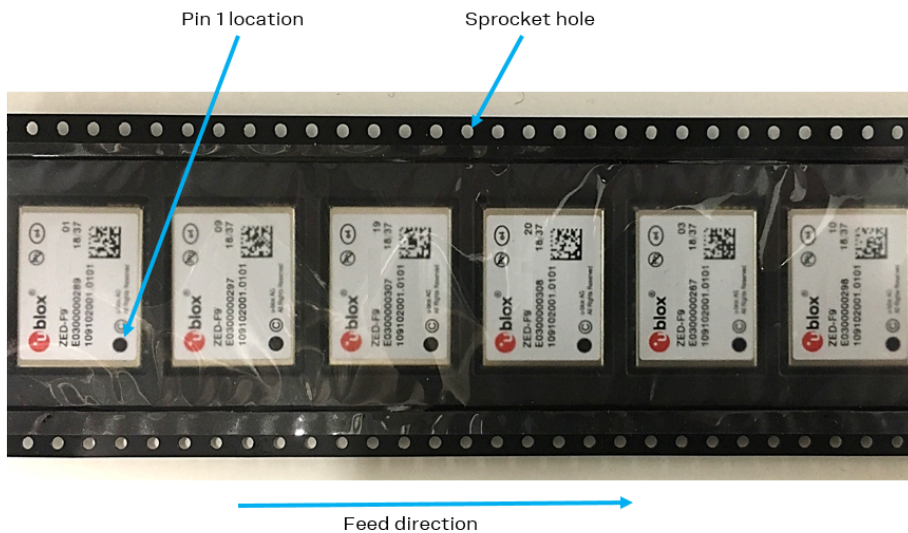
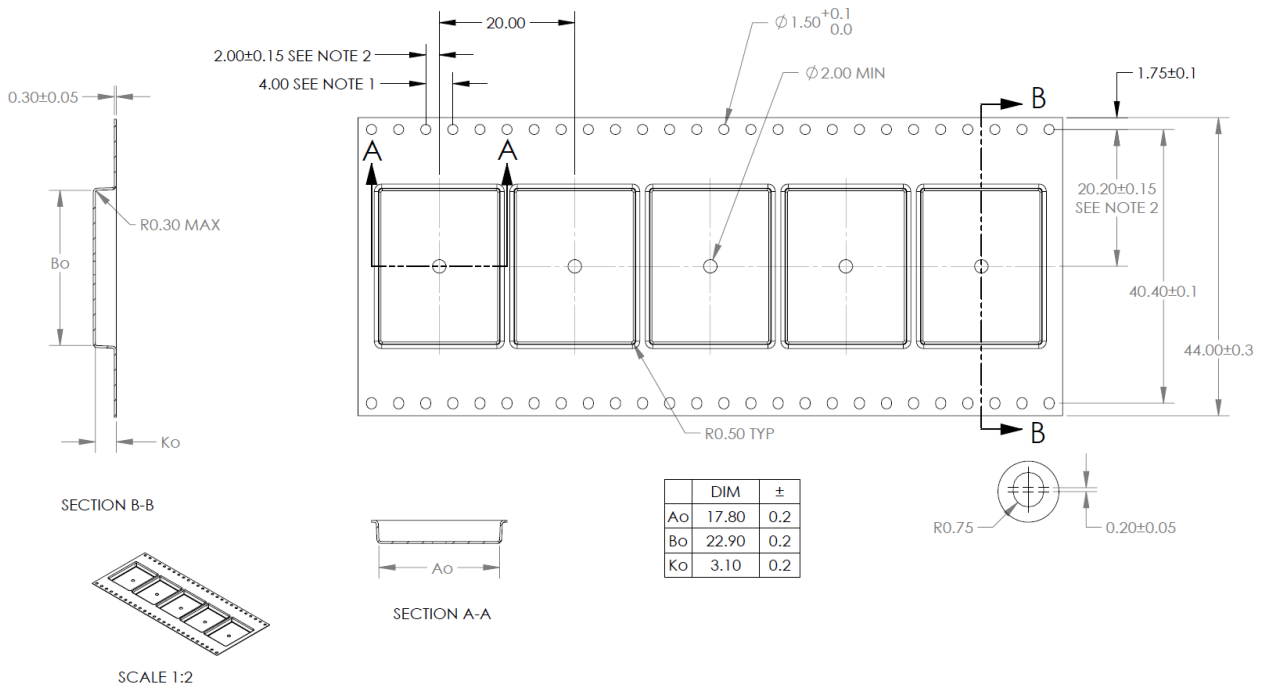

Figure 53: Orientation of ZED-F9K on the tape

The feed direction to the pick and place pick-up is shown by the orientation of the pin 1 location. In Figure 53, with pin 1 location on the bottom of the tape, the feed direction into the pick and place pick-up is from the reel (located on the right of the figure) towards left.

The dimensions of the tapes for ZED-F9K are specified in Figure 54 (measurements in mm).



- NOTES:
1. 10 SPROCKET HOLE PITCH CUMULATIVE TOLERANCE ± 0.2
 2. POCKET POSITION RELATIVE TO SPROCKET HOLE MEASURED AS TRUE POSITION OF POCKET, NOT POCKET HOLE.
 3. Ao AND Bo ARE MEASURED ON A PLANE AT A DISTANCE "R" ABOVE THE BOTTOM OF THE POCKET.

Figure 54: ZED-F9K tape dimensions (mm)

5.4 Reels

The ZED-F9K receivers are deliverable in quantities of 250 pieces on a reel. The receivers are shipped on reel type B, as specified in the u-blox Package Information Guide [4].

5.5 Moisture sensitivity levels

The moisture sensitivity level (MSL) for ZED-F9K is specified in the table below.

Package	MSL level
LGA	4 (ZED-F9K-00B), 3 (ZED-F9K-01A),

Table 33: MSL level



For MSL standard see IPC/JEDEC J-STD-020, which can be downloaded from www.jedec.org.



For more information regarding moisture sensitivity levels, labeling, storage and drying, see the u-blox Package Information Guide [4].

Appendix

A Glossary

Abbreviation	Definition
ACH	Advanced calibration handling
ADR	Automotive dead reckoning
ANSI	American National Standards Institute
ARP	Antenna reference point
BeiDou	Chinese navigation satellite system
BBR	Battery-backed RAM
CDMA	Code-division multiple access
CRP	Configurable reference point
EMC	Electromagnetic compatibility
EMI	Electromagnetic interference
EOS	Electrical overstress
EPA	Electrostatic protective area
ESD	Electrostatic discharge
Galileo	European navigation satellite system
GLONASS	Russian navigation satellite system
GND	Ground
GNSS	Global navigation satellite system
GPS	Global Positioning System
GSM	Global System for Mobile Communications
I2C	Inter-integrated circuit bus
IEC	International Electrotechnical Commission
IMU	Inertial measurement unit
IRP	Inertial measurement unit reference point
ITRF	International Terrestrial Reference Frame
MSM	Multiple signal messages
NTRIP	Networked Transport of RTCM via Internet Protocol
PCB	Printed circuit board
QZSS	Quasi-Zenith Satellite System
RF	Radio frequency
RTCM	Radio Technical Commission for Maritime Services
RTK	Real-Time Kinematic
SBAS	Satellite-based Augmentation System
SV	Space vehicle, a satellite
TDOP	Time dilution of precision
UBX	u-blox
UDR	Untethered dead reckoning
VRP	Vehicle reference point
VRS	Virtual reference station

B Reference frames

Real time kinematic (RTK) is a differential system where the rover uses the corrections from a reference station or a reference station network. The rover receiver will calculate its position in the reference frame used by the service provider in its correction stream. If the output is required in a different reference frame, then a (custom) datum transformation is required.

For example, if an application requires the position in the ITRF14 reference frame but the correction service is using the ETRF14 reference frame - to which the RTK solution will also be referring - then this reference frame offset needs to be compensated. For example if utilizing a truth system which is using corrections referring to different reference frame, it is important to compensate for the reference frame offset to avoid systematic errors in the analysis.

Terrestrial reference system is a coordinate reference system which is rotating in space with the rotation of the Earth. The reference system is an abstract concept that is realized by obtaining coordinates for some points on the surface of the Earth. This kind of realization is called a reference frame. For more details, see for example the [ITRF webpage](#). Commonly used reference systems include International Terrestrial Reference System (ITRS) and European Terrestrial Reference System 1989 (ETRS89).

Widely used reference frames include for example International Terrestrial Reference Frame (ITRF) and European Terrestrial Reference Frame (ETRF). ITRF is a realization of ITRS, done every few years. Latest realizations of ITRF are ITRF2008 and ITRF2014. ETRF is a realization of ETRS89, done every few years. Latest realizations are ITRF2005 and ETRF2014.

For example, the EUREF is used to realize the ETRS89. For information, see their homepage: [EUREF](#).

See the ITRF website for more information and an online transform calculator: [ITRF](#).

Another online tool for transformations is available on the EUREF network page: [EUREF Transformation](#).

Reference frames can have constant offsets between each other but, in addition to that, they can also drift and rotate with respect to each other. One major reason for this is that the tectonic plates move constantly and the reference frames that are attached to the tectonic plates move along with the plates.



The ZED-F9K stores the EGM96 geoid model with limited resolution, leading to degraded precision of the reported mean sea level height and geoid separation. If the user application needs higher geoid separation accuracy, it is required to apply its own adjustment to the ellipsoidal height output from the ZED-F9K.

C RTK configuration procedures with u-center

This section provides some guidance for using u-center to evaluate ZED-F9K RTK operation.

C.1 Receiver configuration with u-center

In this example, UART1 is configured to use a suitable baud rate for communicating with a host PC running u-center. A set of output messages are enabled so that the receiver status can be monitored.

Using the UBX-CFG-VALSET configuration window, set the UART1 interface for the correct host baud rate:

1. Select **Group**: CFG-UART1, **Key name**: CFG-UART1-BAUDRATE. See [Figure 55](#).

UBX - CFG (Config) - VALSET (New Configuration)

Compose list entry

Group:

Key name:

Key ID:

Details

Title:

Description:

Type: U4

Key	Key ID	Type	Value

Value

Layers: Flash BBR RAM

Transaction:

Figure 55: u-center UBX-CFG-VALSET message view

2. Select **Add to List**, it will appear in the table below.
3. Select the added key. It will now give the option of setting or reading the current value. See [Figure 56](#).

UBX - CFG (Config) - VALSET (New Configuration)

Compose list entry

Group:

Key name:

Key ID:

Details

Title:

Description:

Type: U4

Key	Key ID	Type	Value
CFG-UART1-BAUDRATE	0x40520001	U4	-

Value

Layers: Flash BBR RAM

Transaction:

Figure 56: Example u-center UBX-CFG-VALSET message view when selecting a configuration item

4. Add the value, for example, 230400 into the "Value" window that appears below the list. See [Figure 57](#).
5. Set the configuration by clicking the **Send** button at the bottom of the message tree view. Remember to set the u-center baud rate to match the value set in the receiver.

Figure 57: u-center UBX-CFG-VALSET message view for setting the CFG-UART1-BAUDRATE configuration item that controls the baud rate of UART1

Next, some UBX example messages are configured to enable viewing the receiver status.

1. Select **Group**: CFG-MSGOUT, **Key name**: CFG-MSGOUT-UBX, and select the UART1 required messages.
2. Add each message to the list, setting the value of each to 1.
3. Click **Send**. See [Figure 58](#).

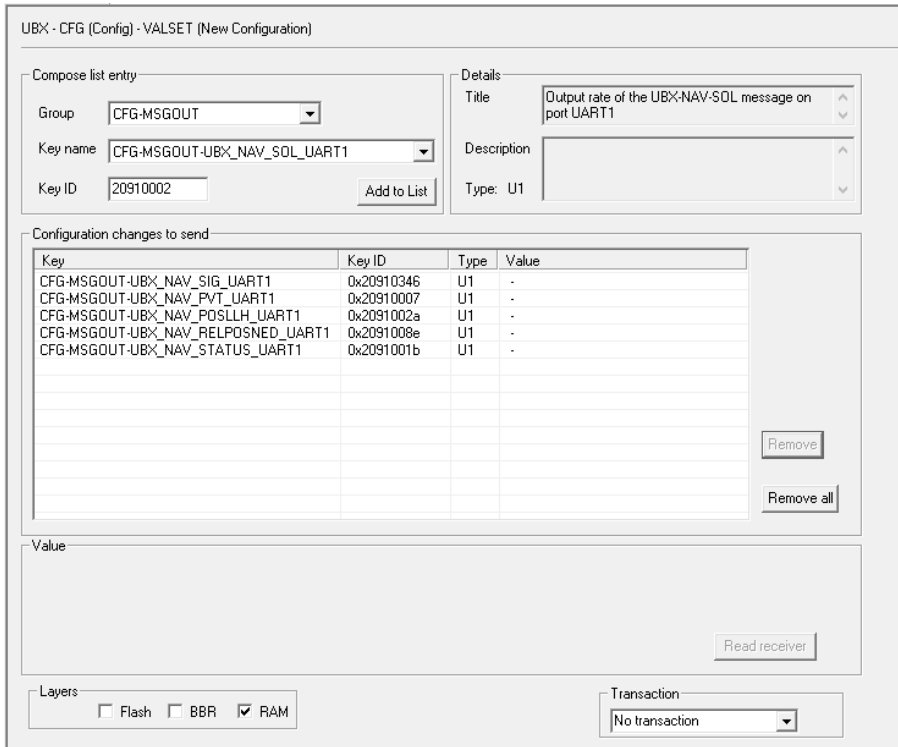

Figure 58: u-center UBX-CFG-VALSET message view for setting the CFG-MSGGOUT-* configuration items for enabling the output of some recommended UBX messages

4. To ensure all the required RTCM messages, including most importantly RTCM 1005, are being received regularly, examine the **UBX-RXM-RTCM** output in u-center. See [Figure 59](#).

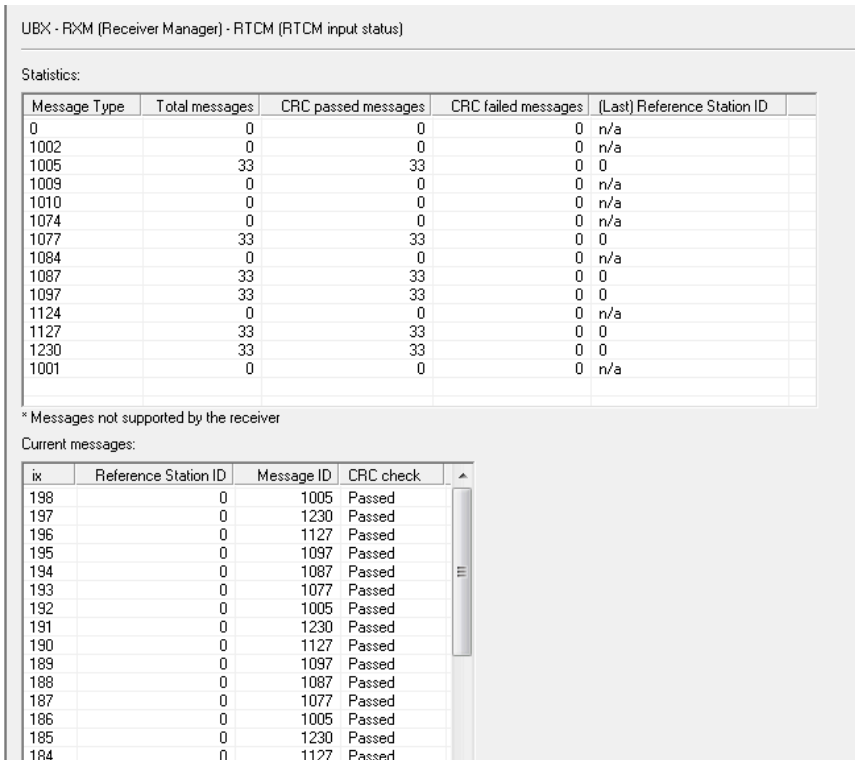

Figure 59: u-center UBX-RXM-RTCM view

- Once the receiver is receiving a valid set of RTCM messages, it should transition through 3D Fix to 3D/DGNSS to Float and, ultimately, into Fixed mode. See [Figure 60](#).

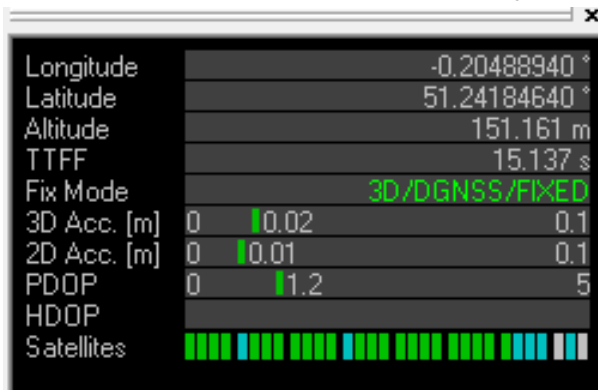

Figure 60: u-center data view with RTK Fixed



If using a VRS service, the receiver must be configured to output NMEA GGA messages to the u-center NTRIP client (UART1 in this example).

Related documents

- [1] ZED-F9K-00B Data sheet, UBX-20032561
ZED-F9K-01A Data sheet, UBX-21045820
- [2] LAP 1.20 Interface description, UBX-20046191
LAP 1.30 Interface description, UBX-22005157
- [3] u-blox F9 LAP 1.30 Release notes, [UBX-22009742](#)
- [4] Packaging information for u-blox chips, modules, and antennas, [UBX-14001652](#)



For regular updates to u-blox documentation and to receive product change notifications please register on our homepage <https://www.u-blox.com>.

Revision history

Revision	Date	Name	Status / comments
R01	06-Nov-2020	ssid	Early production information - ZED-F9K-00B-01
R02	24-Aug-2021	ssid	Advance information - ZED-F9K-00B-02
R03	03-May-2023	ssid	Advance information - ZED-F9K-01A-55 Changes: <ul style="list-style-type: none">- Switching between L1 L2 and L1 L5- SPARTN version 2.0.1 protocol description added- UBX protocol enabled with UART 2- Interrupt-based IMU sensor output description added- UBX-NAV-PVAT supported- Wake on motion description added- Secondary GNSS output description added- Protection level description added- Advanced calibration handling description added- Sensor based spoofing detection description added- Spectrum analyzer description added- Updated I2C and SPI timing specifications in section Communications interfaces
R04	24-Jul-2023	ssid	Initial production - ZED-F9K-01A

Contact

u-blox AG

Address: Zürcherstrasse 68
8800 Thalwil
Switzerland

For further support and contact information, visit us at www.u-blox.com/support.